

Data Sheet | Item Number: 771-8382/166-101

pre-assembled connecting cable; Cca; Socket/open-ended; 2-pole; Cod. I;
H05Z1Z1-F 2 x 1,50 mm²; 1 m; 1,50 mm²

<https://www.wago.com/771-8382/166-101>

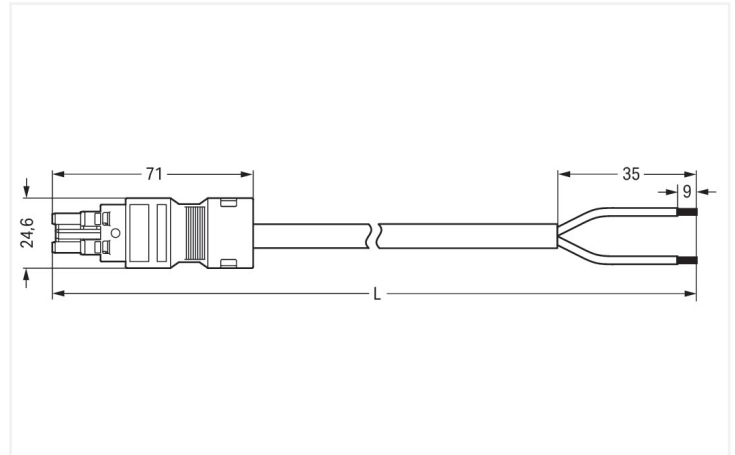
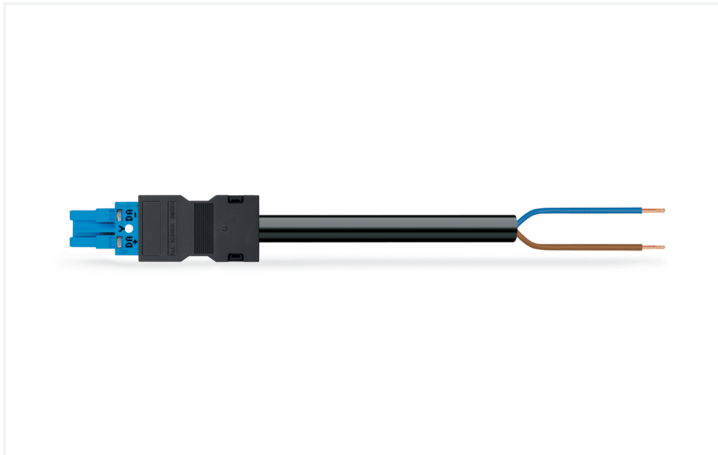

Dimensions in mm

Cable assembly WINSTA® MIDI with protection against mismatching

The WINSTA® MIDI cable assembly rated current 16 A is the pluggable solution for your use in control cabinets, for lighting connections or on PCBs. Our pluggable installation connectors with spring pressure connection technology function completely without screw connections. They allow resource-efficient, error-free installation in a large number of possible uses. The color coding and mechanical coding of the pluggable installation connector ensure error-free installation of the individual components – including protection against mismatching. The pluggable installation connector is protected against ingress by solid objects in accordance with protection type IP20 (When mated: IP2xC (These compact connectors are not designed for use in open, easily accessible areas!)). Regulated lighting, as implemented with the DALI standard, for example, is the primary domain of use of WINSTA® MIDI pluggable installation connectors with I coding. The WINSTA® MIDI product line guarantees flexibility for the electrical installation. With its Push-in CAGE CLAMP® spring pressure connection technology, it ensures error-free, time-saving installation and offers flexibility and customization for meeting all installation requirements. If you need to satisfy stricter safety standards, you should use cables with fire class C. These are suitable for use in buildings with preferably high demands on safety. In the production of this cable assembly, we eliminated the use of halogen. This is an important contribution to environmental protection.

Fast, secure pluggable connections – cable assemblies from WAGO

The cable assembly is provided with a socket and a free end. WINSTA® is the pluggable connection system that is ideally tailored to the strict requirements of electrical installation. It ensures error-free installation of cables and components, quickly and reliably. Now you can also cut installation expenses without compromising quality and safety: with protection type IP20 eliminates the need for servicing and prevents unnecessary downtime.

- effective protection against mismatching
- for automation controllers
- with I coding for use in building automation (lighting control)
- ready to install and use immediately
- rapid, structured electrical installation

Notes

Note Cables with a different fire class can be found in the eShop.

Electrical data

| Ratings per | IEC/EN 60664-1 | | | General information | |
|---------------------------------|----------------|-----|----|----------------------------|--|
| Overvoltage category | III | III | II | Note on contact resistance | approx. 1 mΩ of contact resistance approx. 0.25 mΩ contact transition plug/ socket |
| Pollution degree | 3 | 2 | 2 | | |
| Nominal voltage | 250 V | - | - | | |
| Rated impulse withstand voltage | 4 kV | - | - | | |
| Rated current | 16 A | - | - | | |

Connection Data

| | | | |
|----------------------------|---------------------------|---------------------------------|---------------------|
| Total number of potentials | 2 | Connection 1 | |
| Conductor preparation | ultrasonically tip-bonded | Strip length | 9 mm / 0.35 inches |
| | | Pole number | 2 |
| | | Wire cross-section | 1.5 mm ² |
| | | Strip length (outer insulation) | 35 mm |
| | | Connection type | Socket - free end |

Physical data

| | |
|--------------|------------------------|
| Pin spacing | 10 mm / 0.394 inches |
| Width | 24.6 mm / 0.969 inches |
| Height | 15.9 mm / 0.626 inches |
| Total length | 1 m |

Mechanical data

| | |
|---|---|
| Use | DALI, Lighting Management |
| Coding | I |
| Variable coding | No |
| Marking | DA+ DA- |
| Potential marking | DA+ DA- |
| Mating force of a plug-in connection | approx. 20 ... 70 N (depending on pole number) |
| Retention force of a plug-in connection | when locked: > 80N |
| Unmating force of a plug-in connection | when unlocked: approx. 20 ... 70 N (depending on pole number) |
| Number of mating cycles | 200, without resistive load |
| Connection type | Socket - free end |
| Type of pre-assembled cable | Connecting cable |
| Cable type | H05Z1Z1-F 2x1.5 |
| Protection type | IP20; When mated: IP2xC (These compact connectors are not designed for use in open, easily accessible areas!) |

Plug-in connection

| | |
|-------------------------------|--|
| Mismating protection | Yes |
| Note on mismating protection | All WINSTA® components are 100% protected against mismating when: a.) plugging different numbers of poles b.) plugging while rotated 180 c.) plugging while laterally staggered d.) plugging one pole |
| Locking lever | Can be retrofitted |
| Locking of plug-in connection | Locking lever |
| Note on locking system | All connectors for mounted installations (snap-in versions for lighting fixtures or devices, all types of PCB and distribution connectors) are factory-equipped with locking levers to ensure plugs and sockets are securely locked. Additional locking levers are only required for flying leads (plug/socket). |

Material data

| | |
|------------------------------------|--|
| Note (material data) | Information on material specifications can be found here |
| Insulation material (main housing) | Polyamide (PA66) |
| Flammability class per UL94 | V0 |
| Fire class per EN 50575 | C _{ca} |
| Contact material | Copper or copper alloy; surface-treated |
| Contact Plating | Tin |
| Fire load | 1.132 MJ |
| Connector color | blue |
| Strain relief color | black |
| Sheathed cable color | black |
| Printing color of sheathed cable | white |
| Halogen-free | Yes |
| Silicon-free | Yes |
| Sheath material | Halogen-free |
| Rubber cable | No |
| Weight | 91.4 g |
| Copper weight of the raw cable | 0.029 kg/m |

Environmental requirements

| | |
|--|---|
| Processing temperature | -5 ... +40 °C |
| Continuous operating temperature | -35 ... +85 °C |
| Note on continuous operating temperature | Cable for temperatures ≤ 70 °C (including halogen-free) Insulating parts for temperatures ≤ 105 °C |

Commercial data

| | |
|-----------------------|---------------|
| PU (SPU) | 1 pcs |
| Packaging type | unpacked |
| Country of origin | DE |
| GTIN | 4055143841641 |
| Customs tariff number | 85444290900 |

Product Classification

| | |
|-----------|----------------------|
| UNSPSC | 26121629 |
| ETIM 9.0 | EC002587 |
| ETIM 10.0 | EC002587 |
| ECCN | NO US CLASSIFICATION |

Environmental Product Compliance

| | |
|------------------------|-------------------------|
| RoHS Compliance Status | Compliant, No Exemption |
|------------------------|-------------------------|

Downloads

Environmental Product Compliance

| | |
|--|--|
| Compliance Search | |
| Environmental Product Compliance 771-8382/166-101 | |

1 Compatible Products

1.1 Required Accessories

1.1.1 Locking system

1.1.1.1 Locking system

| | | | |
|---|---|---|---|
| | | | |
| Item No.: 770-101 Locking lever; for flying leads; for manual operation; black | Item No.: 770-121 Locking lever; for flying leads; for manual operation; white | Item No.: 770-111 Locking lever; for flying leads; for tool operation; black | Item No.: 770-131 Locking lever; for flying leads; for tool operation; white |

1.2 Optional Accessories

1.2.1 Cover

1.2.1.1 Cover

| | | |
|---|---|--|
| | | |
| Item No.: 770-201 Lockout cap; 12-pole, separable; for sockets; Plastic; black | Item No.: 770-221 Lockout cap; 12-pole, separable; for sockets; Plastic; white | Item No.: 897-2003 Protective cap; Type2; for sockets and plugs; PVC; red |

1.2.2 Installation

1.2.2.1 Mounting accessories

| |
|--|
| |
| Item No.: 770-310 Mounting carrier; 2- to 5-pole; for flying leads; black |

1.2.3 Marking

1.2.3.1 Marking strip



Item No.: 210-334

Marking strips; as a DIN A4 sheet; Strip width 5 mm; Strip length 182 mm; plain; Self-adhesive; white