

## Data Sheet | Item Number: 771-8382/166-501

pre-assembled connecting cable; Cca; Socket/open-ended; 2-pole; Cod. I;  
H05Z1Z1-F 2 x 1,50 mm<sup>2</sup>; 5 m; 1,50 mm<sup>2</sup>

<https://www.wago.com/771-8382/166-501>

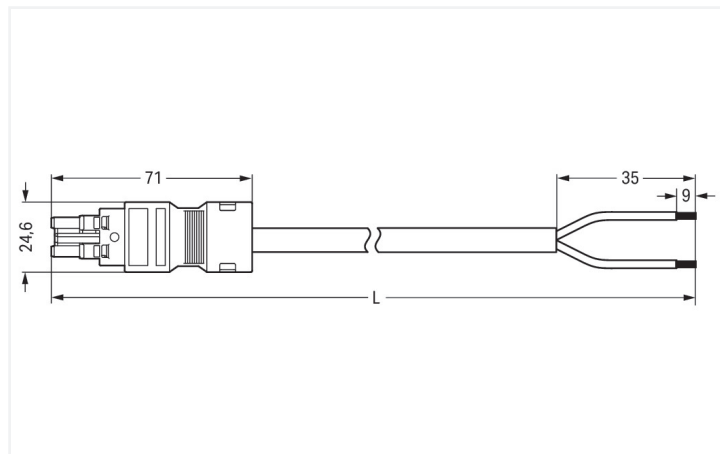
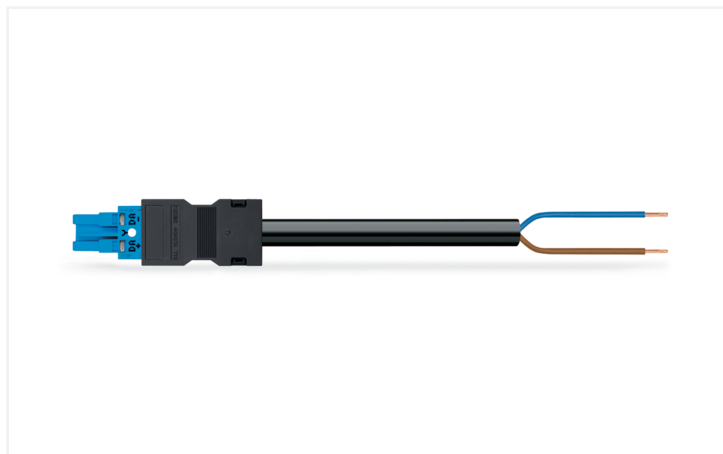

Dimensions in mm

Cable assembly *WINSTA*® MIDI rated current 16 A

The *WINSTA*® MIDI cable assembly with protection against mismatching supports fast, reliable installation. Whether on PCBs, in control cabinets or for connecting lights – pluggable installation connectors from WAGO allow you to establish connections according to many different requirements in next to no time. The coding options reduce installation errors, allowing fast, secure wiring of all components. The pluggable installation connector offers touch-proof protection with live components in accordance with protection type IP20 (When mated: IP2xC (These compact connectors are not designed for use in open, easily accessible areas!)). I coding in blue is used to label *WINSTA*® MIDI pluggable installation connectors, which are used primarily in automation of buildings for activating lighting. Our *WINSTA*® MIDI product line allows maximum flexibility for the installation. With its Push-in CAGE CLAMP® spring pressure connection technology, it guarantees time-saving, error-free installation and offers flexibility for meeting all installation requirements. Anyone who needs to take into account technical safety requirements for fire protection reasons for electrical installation should be able to rely on the quality of the components. Our product meets the official safety standards of fire class C. The cable assembly is free of halogen. This eliminates the addition of environmental pollutants during production. It also achieves a higher fire class, since halogen-free materials do not easily ignite.

Fast, secure pluggable connections – cable assemblies from WAGO

The cable assembly is equipped with a socket and a free end. The *WINSTA*® Pluggable Connection System is perfectly tailored to the strict requirements of building installation. It makes electrical installation pluggable, and consequently faster, even more reliable, and error-free. Use of this pre-assembled system decreases time spent on assembly and errors during installation at the construction site. Now you can also lower installation costs without compromising safety and quality: with marking eliminates the need for servicing and prevents unnecessary downtime.

- protection against mismatching eliminates errors
- pre-assembled versions
- for intelligent, easy lighting installation
- custom-engineered solutions
- convenient installation and commissioning

## Notes

Note Cables with a different fire class can be found in the eShop.

## Electrical data

Ratings per	IEC/EN 60664-1			General information	
Overvoltage category	III	III	II	Note on contact resistance	approx. 1 mΩ of contact resistance approx. 0.25 mΩ contact transition plug/ socket
Pollution degree	3	2	2		
Nominal voltage	250 V	-	-		
Rated impulse withstand voltage	4 kV	-	-		
Rated current	16 A	-	-		

## Connection Data

Total number of potentials	2	<b>Connection 1</b>	
Conductor preparation	ultrasonically tip-bonded	Strip length	9 mm / 0.35 inches
		Pole number	2
		Wire cross-section	1.5 mm <sup>2</sup>
		Strip length (outer insulation)	35 mm
		Connection type	Socket - free end

## Physical data

Pin spacing	10 mm / 0.394 inches
Width	24.6 mm / 0.969 inches
Height	15.9 mm / 0.626 inches
Total length	5 m

## Mechanical data

Use	DALI, Lighting Management
Coding	I
Variable coding	No
Marking	DA+ DA-
Potential marking	DA+ DA-
Mating force of a plug-in connection	approx. 20 ... 70 N (depending on pole number)
Retention force of a plug-in connection	when locked: > 80N
Unmating force of a plug-in connection	when unlocked: approx. 20 ... 70 N (depending on pole number)
Number of mating cycles	200, without resistive load
Connection type	Socket - free end
Type of pre-assembled cable	Connecting cable
Cable type	H05Z1Z1-F 2x1.5
Protection type	IP20; When mated: IP2xC (These compact connectors are not designed for use in open, easily accessible areas!)

### Plug-in connection

Mismating protection	Yes
Note on mismating protection	All WINSTA® components are 100% protected against mismating when: a.) plugging different numbers of poles b.) plugging while rotated 180 c.) plugging while laterally staggered d.) plugging one pole
Locking lever	Can be retrofitted
Locking of plug-in connection	Locking lever
Note on locking system	All connectors for mounted installations (snap-in versions for lighting fixtures or devices, all types of PCB and distribution connectors) are factory-equipped with locking levers to ensure plugs and sockets are securely locked. Additional locking levers are only required for flying leads (plug/socket).

### Material data

Note (material data)	<a href="#">Information on material specifications can be found here</a>
Insulation material (main housing)	Polyamide (PA66)
Flammability class per UL94	V0
Fire class per EN 50575	C <sub>ca</sub>
Contact material	Copper or copper alloy; surface-treated
Contact Plating	Tin
Fire load	4.588 MJ
Connector color	blue
Strain relief color	black
Sheathed cable color	black
Printing color of sheathed cable	white
Halogen-free	Yes
Silicon-free	Yes
Sheath material	Halogen-free
Rubber cable	No
Weight	411.4 g
Copper weight of the raw cable	0.029 kg/m

### Environmental requirements

Processing temperature	-5 ... +40 °C
Continuous operating temperature	-35 ... +85 °C
Note on continuous operating temperature	Cable for temperatures ≤ 70 °C (including halogen-free) Insulating parts for temperatures ≤ 105 °C

### Commercial data

PU (SPU)	1 pcs
Packaging type	unpacked
Country of origin	DE
GTIN	4055143841757
Customs tariff number	85444290900

**Product Classification**

UNSPSC	26121629
ETIM 9.0	EC002587
ETIM 10.0	EC002587
ECCN	NO US CLASSIFICATION

**Environmental Product Compliance**

RoHS Compliance Status	Compliant, No Exemption
------------------------	-------------------------

**Downloads**

**Environmental Product Compliance**

Compliance Search	
Environmental Product Compliance 771-8382/166-501	

**1 Compatible Products**

**1.1 Required Accessories**

**1.1.1 Locking system**

**1.1.1.1 Locking system**

<a href="#">Item No.: 770-101</a> Locking lever; for flying leads; for manual operation; black	<a href="#">Item No.: 770-121</a> Locking lever; for flying leads; for manual operation; white	<a href="#">Item No.: 770-111</a> Locking lever; for flying leads; for tool operation; black	<a href="#">Item No.: 770-131</a> Locking lever; for flying leads; for tool operation; white

**1.2 Optional Accessories**

**1.2.1 Cover**

**1.2.1.1 Cover**

<a href="#">Item No.: 770-201</a> Lockout cap; 12-pole, separable; for sockets; Plastic; black	<a href="#">Item No.: 770-221</a> Lockout cap; 12-pole, separable; for sockets; Plastic; white	<a href="#">Item No.: 897-2003</a> Protective cap; Type2; for sockets and plugs; PVC; red

**1.2.2 Installation**

**1.2.2.1 Mounting accessories**

<a href="#">Item No.: 770-310</a> Mounting carrier; 2- to 5-pole; for flying leads; black

## 1.2.3 Marking

### 1.2.3.1 Marking strip



**Item No.: 210-334**

Marking strips; as a DIN A4 sheet; Strip width 5 mm; Strip length 182 mm; plain; Self-adhesive; white