

Data Sheet | Item Number: 771-8382/266-101

pre-assembled connecting cable; Cca; Plug/open-ended; 2-pole; Cod. I; H05Z1Z1-F
2 x 1,50 mm²; 1 m; 1,50 mm²

<https://www.wago.com/771-8382/266-101>

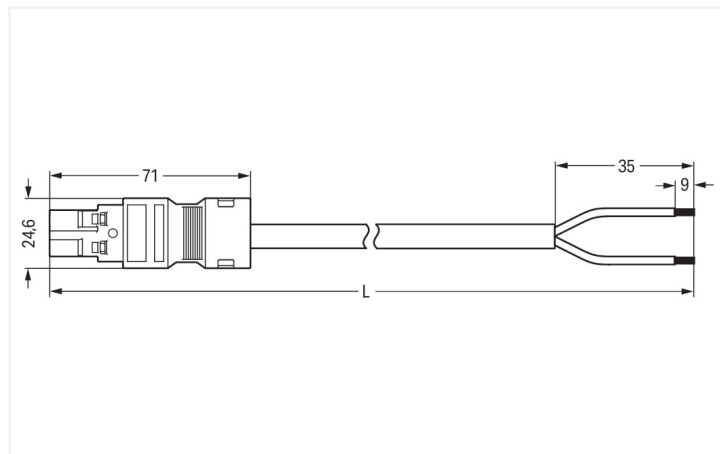
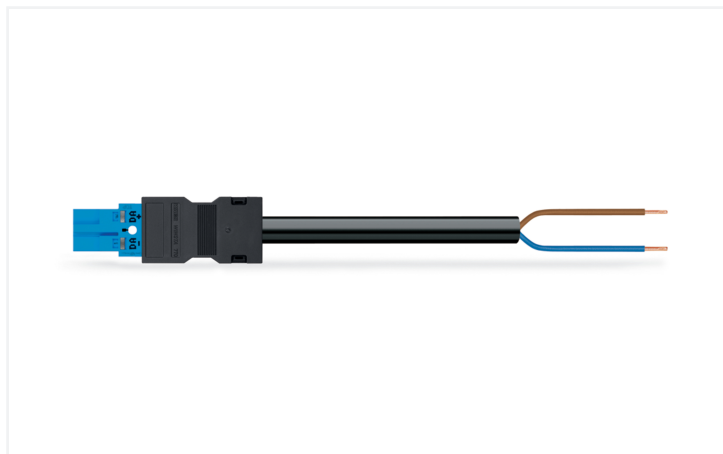

Dimensions in mm

Cable assembly WINSTA® MIDI with protection type IP20

The WINSTA® MIDI cable assembly rated current 16 A supports fast, reliable installation. Whether on PCBs, in control cabinets or for connecting lights – pluggable installation connectors from WAGO allow you to make connections according to an enormous variety of requirements in seconds. For greater security in electrical installations, the pluggable installation connector is equipped with mechanical protection against mismatching. The pluggable installation connector offers protection against contact with live components in accordance with protection type IP20 (When mated: IP2xC (These compact connectors are not designed for use in open, easily accessible areas!)). WINSTA® MIDI pluggable installation connectors with I coding in blue are especially suitable for lighting management, for instance for the dimming function of DALI lights. The WINSTA® MIDI Pluggable Connection System with Push-in CAGE CLAMP® spring pressure connection technology facilitates exemplary electrification. Thanks to the included test slot, connections can be checked even when they are plugged in. This saves time, labor, and money. If you need to satisfy stricter safety standards, you should use cables with fire class C. These are suitable for use in buildings with preferably high demands on safety. The cable assembly is halogen-free. This eliminates the addition of environmental pollutants during production. It also achieves a higher fire class, since halogen-free materials are flame-resistant.

Fast, secure pluggable connections – cable assemblies from WAGO

The cable is pre-assembled with a plug and a free end. The WINSTA® Pluggable Connection System is perfectly tailored to the strict requirements of building installation. It makes electrical installation pluggable, and consequently faster, even more reliable, and error-free. Use of this pre-assembled system reduces assembly times and errors during installation at the construction site. Now you can also lower installation expenses without compromising quality and safety: with protection type IP20 reduces the need for servicing and prevents unnecessary downtime.

- protection against mismatching eliminates errors
- simple circuits
- with I coding for lighting control (DALI standard)
- exact dimensions
- fast, secure installation

Notes

Note Cables with a different fire class can be found in the eShop.

Electrical data

Ratings per	IEC/EN 60664-1			General information	
Overvoltage category	III	III	II	Note on contact resistance	approx. 1 mΩ of contact resistance approx. 0.25 mΩ contact transition plug/ socket
Pollution degree	3	2	2		
Nominal voltage	250 V	-	-		
Rated impulse withstand voltage	4 kV	-	-		
Rated current	16 A	-	-		

Connection data

Total number of potentials	2	Connection 1	
Conductor preparation	ultrasonically tip-bonded	Strip length	9 mm / 0.35 inches
		Pole number	2
		Wire cross-section	1.5 mm ²
		Strip length (outer insulation)	35 mm
		Connection type	Plug - free end

Physical data

Pin spacing	10 mm / 0.394 inches
Width	24.6 mm / 0.969 inches
Height	15.9 mm / 0.626 inches
Total length	1 m

Mechanical data

Use	DALI, Lighting Management
Coding	I
Variable coding	No
Marking	DA+ DA-
Potential marking	DA+ DA-
Mating force of a plug-in connection	approx. 20 ... 70 N (depending on pole number)
Retention force of a plug-in connection	when locked: > 80N
Unmating force of a plug-in connection	when unlocked: approx. 20 ... 70 N (depending on pole number)
Number of mating cycles	200, without resistive load
Connection type	Plug - free end
Type of pre-assembled cable	Connecting cable
Cable type	H05Z1Z1-F 2x1.5
Protection type	IP20; When mated: IP2xC (These compact connectors are not designed for use in open, easily accessible areas!)

Plug-in connection

Mismating protection	Yes
Note on mismating protection	All WINSTA® components are 100% protected against mismating when: a.) plugging different numbers of poles b.) plugging while rotated 180 c.) plugging while laterally staggered d.) plugging one pole
Locking lever	Can be retrofitted
Locking of plug-in connection	Locking lever
Note on locking system	All connectors for mounted installations (snap-in versions for lighting fixtures or devices, all types of PCB and distribution connectors) are factory-equipped with locking levers to ensure plugs and sockets are securely locked. Additional locking levers are only required for flying leads (plug/socket).

Material data

Note (material data)	Information on material specifications can be found here
Insulation material (main housing)	Polyamide (PA66)
Flammability class per UL94	V0
Fire class per EN 50575	C _{ca}
Contact material	Copper or copper alloy; surface-treated
Contact Plating	Tin
Fire load	1.139 MJ
Connector color	blue
Strain relief color	black
Sheathed cable color	black
Printing color of sheathed cable	white
Halogen-free	Yes
Silicon-free	Yes
Sheath material	Halogen-free
Rubber cable	No
Weight	91.3 g
Copper weight of the raw cable	0.029 kg/m

Environmental requirements

Processing temperature	-5 ... +40 °C
Continuous operating temperature	-35 ... +85 °C
Note on continuous operating temperature	Cable for temperatures ≤ 70 °C (including halogen-free) Insulating parts for temperatures ≤ 105 °C

Commercial data

PU (SPU)	1 pcs
Packaging type	unpacked
Country of origin	DE
GTIN	4055143841870
Customs tariff number	85444290900

Product Classification

UNSPSC	26121629
ETIM 9.0	EC002587
ETIM 8.0	EC002587
ECCN	NO US CLASSIFICATION

Environmental Product Compliance

RoHS Compliance Status	Compliant, No Exemption
------------------------	-------------------------

Downloads

Environmental Product Compliance

Compliance Search	
Environmental Product Compliance 771-8382/266-101	

1 Compatible Products

1.1 Required Accessories

1.1.1 Locking system

1.1.1.1 Locking system

Item No.: 770-101 Locking lever; for flying leads; for manual operation; black	Item No.: 770-121 Locking lever; for flying leads; for manual operation; white	Item No.: 770-111 Locking lever; for flying leads; for tool operation; black	Item No.: 770-131 Locking lever; for flying leads; for tool operation; white

1.2 Optional Accessories

1.2.1 Cover

1.2.1.1 Cover

Item No.: 770-360 Lockout cap; for plugs; 5-pole; separable; yellow	Item No.: 897-2003 Protective cap; Type2; for sockets and plugs; PVC; red

1.2.2 Installation

1.2.2.1 Mounting accessories

Item No.: 770-310 Mounting carrier; 2- to 5-pole; for flying leads; black

1.2.3 Marking

1.2.3.1 Marking strip



Item No.: 210-334

Marking strips; as a DIN A4 sheet; Strip width 5 mm; Strip length 182 mm; plain; Self-adhesive; white