

# Concord

Solstice 150 1550lm LUMI 940 SSC  
2070144

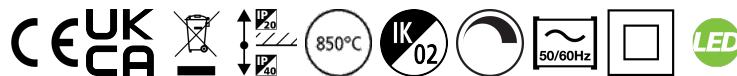

## Features

- The Solstice 150 1550lm LUMI 940 SSC is a high efficient SSC dimmable downlight luminaire, Colour rendering index Ra>97, Colour temperature: 4000K Neutral White, Class II, Protection rating IP40/IP20, Cut out dimensions: 150mm.

## Product Overview

Product name	Solstice 150 1550lm LUMI 940 SSC
Technology	LED
Cap/Base	N/A
Housing	Aluminium
Mount	Ceiling recessed mounting
E-number FI	4262057
Fixture luminous flux (lm)	1550
Luminaire efficacy (lm/W)	91
LOR (%)	100
Colour temperature (K)	4000
Light colour	Neutral White
CRI (Ra)	97
Colour Consistency (SDCM)	3
Colour Variation Initial (SDCM)	3
Glare control	< 19
Photobiological Risk Group	RG1
Total power consumption (W)	17
Electrical protection	Class II
Control gear type	LED driver constant current
LED Flickering Rate	Ultra low (5% or less)
Housing colour	RAL 9016 - Traffic white / Bezel

# Concord

Solstice 150 1550lm LUMI 940 SSC  
2070144

IP rating	IP40/20
IK rating	IK02
Product EAN number	5025768701445
Warranty	5 years

## Photometry

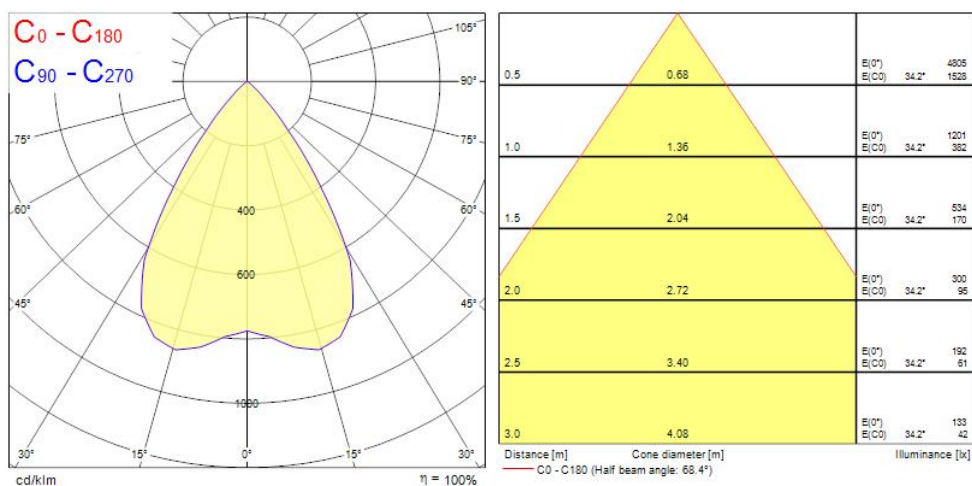

## Technical drawings

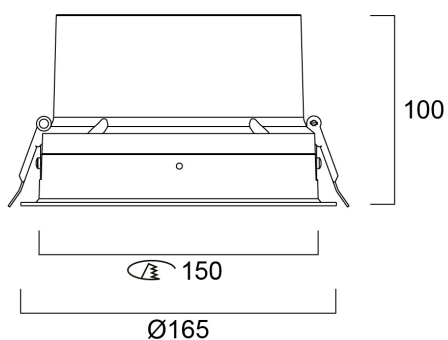

# Concord

## Solstice 150 1550lm LUMI 940 SSC 2070144

### Data table

#### GENERAL DATA

Product name	Solstice 150 1550lm LUMI 940 SSC
Technology	LED
Cap/Base	N/A
Housing	Aluminium
Mount	Ceiling recessed mounting
Operating temperature range (°C)	-10°C...+40°C
Performance ambient temperature Tq (°C)	40
E-number FI	4262057
Warranty	5 years

#### OPTICAL DATA

Fixture luminous flux (lm)	1550
Luminaire efficacy (lm/W)	91
LOR (%)	100
Colour temperature (K)	4000
Light colour	Neutral White
CRI (Ra)	97
Colour Consistency (SDCM)	3
Colour Variation Initial (SDCM)	3
Glare control	< 19
Photobiological Risk Group	RG1

#### ELECTRICAL DATA

Total power consumption (W)	17
Primary Supply/Product voltage - min (V)	220
Lamp power factor	0.96
Electrical protection	Class II
Control gear required	No
Control gear type	LED driver constant current

# Concord

## Solstice 150 1550lm LUMI 940 SSC 2070144

Drive current (mA)	450
Inrush Current (A)	20
Inrush Duration (µs)	140
Glow Wire Test (°C)	850
Energy Efficiency Class (A->G) of contained light source	E
Nominal Frequency (Hz)	50/60Hz
LED Flickering Rate	Ultra low (5% or less)
Max. products per 10A C Breaker	40
Max. products per 20A B Breaker	44
Connectable conductor cross section - Min (mm <sup>2</sup> )	0.5
Connectable conductor cross section - Max (mm <sup>2</sup> )	2.5

### LIFETIME DATA

Lifespan L70 B50	90000
Lifespan L80 B20	90000
Lifespan L80 B10	90000
Lifespan L90 B10	90000

### PHYSICAL DATA

Housing colour	RAL 9016 - Traffic white / Bezel
IP rating	IP40/20
IK rating	IK02
Diffuser finish	Diffuse
Diffuser material	PC Polycarbonate
Nominal Product Diameter (mm)	165
Max. Lamp Diameter (mm) - D	165
Weight (kg)	0.95
Recessed Depth (mm)	150

### PACKAGING

Single packaging type	Carton
-----------------------	--------

# Concord

Solstice 150 1550lm LUMI 940 SSC  
**2070144**

Product EAN number	5025768701445
Packaging single width (cm)	25.0
Packaging single depth (cm)	12.5
DUN14 (outer)	05025768701445
Packaging outer length / height (cm)	27.5

## SAFETY DATA

Optimal operating condition (°C)	-10-40
Special purpose lamp	No
Dry applications use only	No
Suitable for household illumination	No