

Data Sheet | Item Number: 891-8385/166-101

pre-assembled connecting cable; Cca; Socket/open-ended; 5-pole; Cod. I;
H05Z1Z1-F 5G 1.5 mm²; 1 m; 1,50 mm²

<https://www.wago.com/891-8385/166-101>

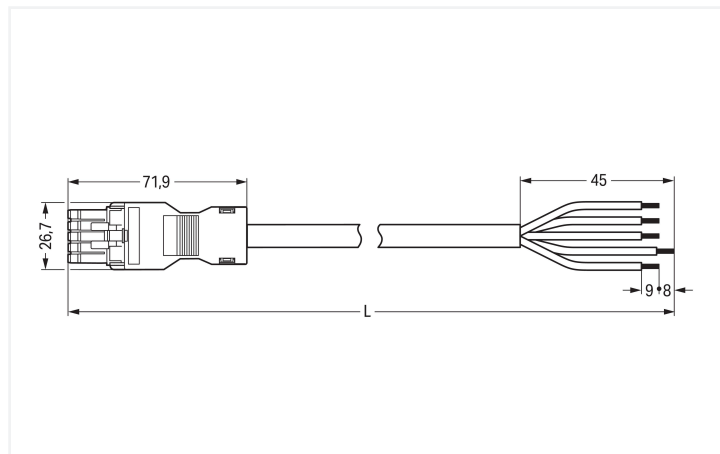
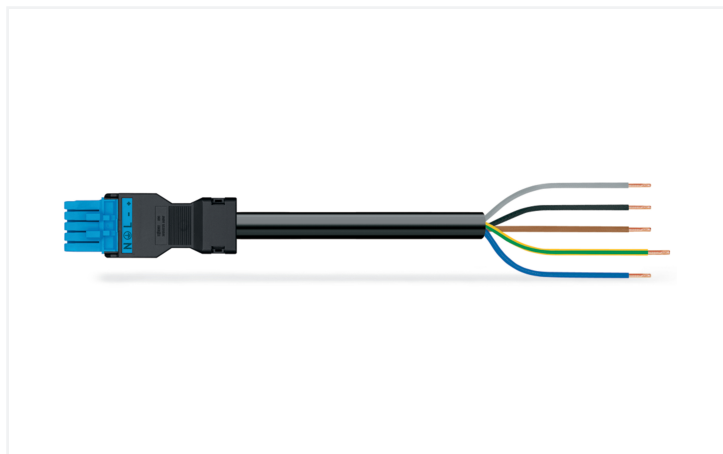

Dimensions in mm

Cable assembly WINSTA® MINI 5-pole

The WINSTA® MINI cable assembly I coding is the pluggable solution for your use in control cabinets, for lighting connections or on PCBs. On PCBs, in control cabinets or for connecting lights – pluggable installation connectors from WAGO allow you to establish connections according to many different requirements in seconds. For greater protection in electrical installations, the pluggable installation connector is equipped with mechanical protection against mismatching. The pluggable installation connector is protected in accordance with protection type IP40. Users' hands and tools will never come into contact with live elements. I coding in blue is used to identify WINSTA® MINI pluggable installation connectors, which are used predominantly in building automation for activating lighting. Particularly if only limited space is available, our smallest pluggable connection system, WINSTA® MINI, conveniently displays its advantageous properties. It is very compact, and, with Push-in CAGE CLAMP® spring pressure connection technology, it additionally can be installed quickly, since the connection is low-maintenance and can be performed without screw connections. If you need to meet stricter safety standards, you should use cables with fire class C. These are suitable for use in buildings with special high demands on safety. The cable assembly is free of halogen. This eliminates the addition of environmental pollutants during production. It also increases the fire class, since halogen-free materials are flame-resistant.

Fast, secure pluggable connections – cable assemblies from WAGO

The cable assembly is equipped with a socket and a free end. The WINSTA® Pluggable Connection System is ideally tailored to the very strict requirements of building installation. It makes electrical installation pluggable, and therefore faster, even more reliable, and error-free. Use of this pre-assembled system decreases assembly times and installation errors at the construction site. Choose durability and quality – with strain relief hosting from WAGO makes the electrical installation of electrical components substantially easier.

- protection against mismatching eliminates errors
- compact design for conductors with a cross-section up to 1.5 mm²
- with I coding for controlling light (DALI standard)
- flexible installation to save space
- convenient installation and commissioning

Notes

Note Cables with a different fire class can be found in the eShop.

Electrical data

Ratings per	IEC/EN 60664-1			General information	
Overvoltage category	III	III	II	Note on contact resistance	approx. 1 mΩ of contact resistance approx. 0.25 mΩ contact transition plug/ socket
Pollution degree	3	2	2		
Nominal voltage	400 V	-	-		
Rated impulse withstand voltage	6 kV	-	-		
Rated current	16 A	-	-		

Connection Data

Total number of potentials	5	Connection 1	
Conductor preparation	ultrasonically tip-bonded	Strip length	9 mm / 0.35 inches
		Pole number	5
		Wire cross-section	1.5 mm ²
		Strip length (outer insulation)	45 mm
		Connection type	Socket - free end

Physical data

Pin spacing	4.4 mm / 0.173 inches
Width	26.7 mm / 1.051 inches
Height	15.8 mm / 0.622 inches
Total length	1 m

Mechanical data

Use	DALI, Lighting Management
Coding	I
Variable coding	No
Marking	N ⊕ L - +
Potential marking	N ⊕ L - +
Mating force of a plug-in connection	approx. 20 ... 70 N (depending on pole number)
Retention force of a plug-in connection	when locked: > 80N
Unmating force of a plug-in connection	when unlocked: approx. 20 ... 70 N (depending on pole number)
Number of mating cycles	200, without resistive load
Connection type	Socket - free end
Type of pre-assembled cable	Connecting cable
Cable type	H05Z1Z1-F 5G1.5
Protection type	IP40

Plug-in connection

Mismating protection	Yes
Note on mismating protection	All WINSTA® components are 100% protected against mismating when: a.) plugging different numbers of poles b.) plugging while rotated 180 c.) plugging while laterally staggered d.) plugging one pole
Locking lever	Can be retrofitted
Locking of plug-in connection	Locking lever
Note on locking system	All connectors for mounted installations (snap-in versions for lighting fixtures or devices, all types of PCB and distribution connectors) are factory-equipped with locking levers to ensure plugs and sockets are securely locked. Additional locking levers are only required for flying leads (plug/socket).

Material data

Note (material data)	Information on material specifications can be found here
Insulation material (main housing)	Polyamide (PA66)
Flammability class per UL94	V0
Fire class per EN 50575	C _{ca}
Contact material	Copper or copper alloy; surface-treated
Contact Plating	Tin
Fire load	14.861 MJ
Connector color	blue
Strain relief color	black
Sheathed cable color	black
Printing color of sheathed cable	white
Halogen-free	Yes
Silicon-free	Yes
Sheath material	Halogen-free
Rubber cable	No
Weight	185.1 g
Copper weight of the raw cable	0.072 kg/m

Environmental requirements

Processing temperature	-5 ... +40 °C
Continuous operating temperature	-35 ... +85 °C
Note on continuous operating temperature	Cable for temperatures ≤ 70 °C (including halogen-free) Insulating parts for temperatures ≤ 105 °C

Commercial data

PU (SPU)	1 pcs
Packaging type	unpacked
Country of origin	PL
GTIN	4055143840668
Customs tariff number	85444290900

Product Classification	
UNSPSC	26121629
ETIM 9.0	EC002587
ETIM 10.0	EC002587
ECCN	NO US CLASSIFICATION

Environmental Product Compliance	
RoHS Compliance Status	Compliant, No Exemption

Downloads

Environmental Product Compliance

Compliance Search
Environmental Product Compliance 891-8385/166-101 

1 Compatible Products

1.1 Required Accessories

1.1.1 Locking system

1.1.1.1 Locking system



[Item No.: 890-111](#)
 Locking lever; for flying leads; for tool operation; black

[Item No.: 890-131](#)
 Locking lever; for flying leads; for tool operation; white

[Item No.: 890-101](#)
 Locking lever; for manual operation; black

[Item No.: 890-121](#)
 Locking lever; for manual operation; white

1.2 Optional Accessories

1.2.1 Cover

1.2.1.1 Cover



[Item No.: 897-2003](#)
 Protective cap; Type2; for sockets and plugs; PVC; red

1.2.2 Installation

1.2.2.1 Mounting accessories



[Item No.: 890-310](#)
 Mounting carrier; 2- to 5-pole; for flying leads; black

[Item No.: 890-311](#)
 Mounting carrier; 2- to 5-pole; for flying leads; white

Subject to changes. Please also observe the further product documentation!

Current addresses can be found at: www.wago.com