

## Data Sheet | Item Number: 891-8385/266-201

pre-assembled connecting cable; Cca; Plug/open-ended; 5-pole; Cod. I; H05Z1Z1-F  
5G 1.5 mm<sup>2</sup>; 2 m; 1,50 mm<sup>2</sup>; blue

<https://www.wago.com/891-8385/266-201>

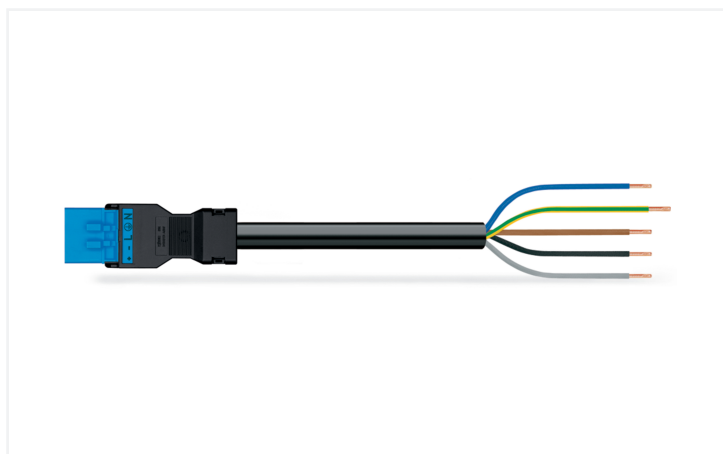

Color: ■ blue

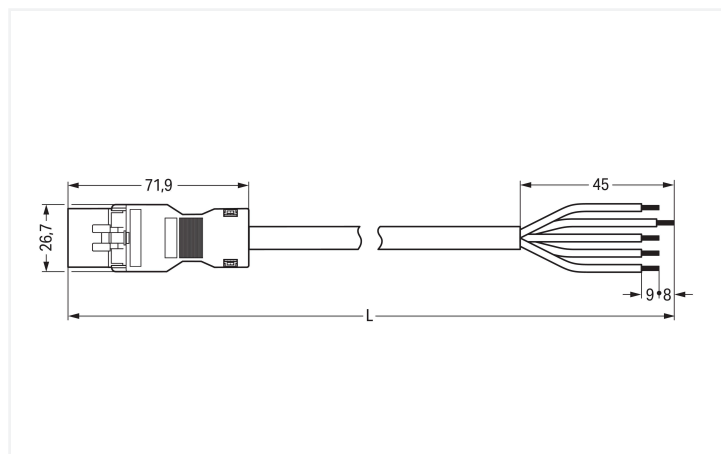

Dimensions in mm

### Cable assembly WINSTA® MINI with strain relief

For power and signal transmission: The WINSTA® MINI cable assembly I coding, WAGO pluggable installation connectors can be used when criteria repeat or are distributed on a specific pattern, for example for installing grid lighting or flush-mount lighting. For greater security in electrical installations, the pluggable installation connector is provided with mechanical protection against mismatching. WINSTA® MINI pluggable installation connectors with I coding in blue are above all suitable for lighting management, for instance for the dimming function of DALI lights. Due to its particularly minimal dimensions, our WINSTA® MINI Pluggable Connection System with Push-in CAGE CLAMP® spring pressure connection technology is very suitable in very restricted spaces, i.e., for connections when very little room is available. Mandatory compliance with fire protection regulations is an essential issue for building installation. Especially in sensitive areas, the fire class must meet or even exceed legal requirements. This product complies with the requirements of fire class C. Eliminating halogens as an additive in the manufacture of this cable assembly substantially improves fire safety and reduces environmental contamination.

### Pluggable connections instead of screw connections – cable assemblies from WAGO

The cable assembly is provided with a plug and a free end. The WINSTA® Pluggable Connection System allows pluggable electrical installation. This saves time, lowers costs, and reduces the need for servicing. Now you can also cut installation expenses without compromising quality and safety: with fire class C eliminates the need for servicing and prevents unnecessary downtime.

- pluggable installation connectors with protection against mismatching
- consistent IP40 protection
- with I coding for use in the automation of buildings (lighting control)
- flexible installation to save space
- quick replacement of defective units during ongoing operation

### Notes

Note Cables with a different fire class can be found in the eShop.

## Electrical data

Ratings per	IEC/EN 60664-1		
Overvoltage category	III	III	II
Pollution degree	3	2	2
Nominal voltage	400 V	-	-
Rated impulse withstand voltage	6 kV	-	-
Rated current	16 A	-	-

## General information

Note on contact resistance	approx. 1 mΩ of contact resistance approx. 0.25 mΩ contact transition plug/ socket
----------------------------	--

## Connection Data

Total number of potentials	5
PE function	Preceding PE contact
Conductor preparation	ultrasonically tip-bonded

## Connection 1

Strip length	9 mm / 0.35 inches
Pole number	5
Wire cross-section	1.5 mm <sup>2</sup>
Strip length (outer insulation)	45 mm
Connection type	Plug - free end

## Physical data

Pin spacing	4.4 mm / 0.173 inches
Width	26.7 mm / 1.051 inches
Height	15.8 mm / 0.622 inches
Total length	2 m

## Mechanical data

Use	DALI, Lighting Management
Coding	I
Variable coding	No
Marking	N ⊕ L - +
Potential marking	N ⊕ L - +
Mating force of a plug-in connection	approx. 20 ... 70 N (depending on pole number)
Retention force of a plug-in connection	when locked: > 80N
Unmating force of a plug-in connection	when unlocked: approx. 20 ... 70 N (depending on pole number)
Number of mating cycles	200, without resistive load
Connection type	Plug - free end
Type of pre-assembled cable	Connecting cable
Cable type	H05Z1Z1-F 5G1.5
Protection type	IP20; IP40 when mated

## Plug-in connection

Mismating protection	Yes
Note on mismating protection	All WINSTA® components are 100% protected against mismating when: a.) plugging different numbers of poles b.) plugging while rotated 180 c.) plugging while laterally staggered d.) plugging one pole
Locking lever	Can be retrofitted
Locking of plug-in connection	Locking lever
Note on locking system	All connectors for mounted installations (snap-in versions for lighting fixtures or devices, all types of PCB and distribution connectors) are factory-equipped with locking levers to ensure plugs and sockets are securely locked. Additional locking levers are only required for flying leads (plug/socket).

### Material data

Note (material data)	<a href="#">Information on material specifications can be found here</a>
Color	blue
Material group	I
Insulation material (main housing)	Polyamide (PA66)
Flammability class per UL94	V0
Fire class per EN 50575	C <sub>ca</sub>
Contact material	Copper or copper alloy; surface-treated
Contact Plating	Tin
Fire load	29.606 MJ
Connector color	blue
Printing color of mating face	white
Strain relief color	black
Sheathed cable color	black
Printing color of sheathed cable	white
Halogen-free	Yes
Silicon-free	Yes
Sheath material	Halogen-free
Rubber cable	No
Weight	359.8 g
Copper weight of the raw cable	0.072 kg/m

### Environmental requirements

Processing temperature	-5 ... +40 °C
Continuous operating temperature	-35 ... +85 °C
Note on continuous operating temperature	Cable for temperatures ≤ 70 °C (including halogen-free) Insulating parts for temperatures ≤ 105 °C

### Commercial data

PU (SPU)	1 pcs
Packaging type	unpacked
Country of origin	PL
GTIN	4055143943185
Customs tariff number	85444290900

### Product Classification

UNSPSC	26121629
ETIM 9.0	EC002587
ETIM 10.0	EC002587
ECCN	NO US CLASSIFICATION

### Environmental Product Compliance

RoHS Compliance Status	Compliant, No Exemption
------------------------	-------------------------

## Downloads

### Environmental Product Compliance

#### Compliance Search

Environmental Product  
Compliance  
891-8385/266-201



## 1 Compatible Products

### 1.1 Required Accessories

#### 1.1.1 Locking system

##### 1.1.1.1 Locking system



[Item No.: 890-111](#)

Locking lever; for flying leads; for tool operation; black



[Item No.: 890-131](#)

Locking lever; for flying leads; for tool operation; white



[Item No.: 890-101](#)

Locking lever; for manual operation; black



[Item No.: 890-121](#)

Locking lever; for manual operation; white

### 1.2 Optional Accessories

#### 1.2.1 Cover

##### 1.2.1.1 Cover



[Item No.: 897-2003](#)

Protective cap; Type2; for sockets and plugs; PVC; red

#### 1.2.2 Installation

##### 1.2.2.1 Mounting accessories



[Item No.: 890-310](#)

Mounting carrier; 2- to 5-pole; for flying leads; black



[Item No.: 890-311](#)

Mounting carrier; 2- to 5-pole; for flying leads; white