

Data Sheet | Item Number: 891-8382/266-501

pre-assembled connecting cable; Cca; Plug/open-ended; 2-pole; Cod. I; H05Z1Z1-F
2 x 1,50 mm²; 5 m; 1,50 mm²; blue

<https://www.wago.com/891-8382/266-501>

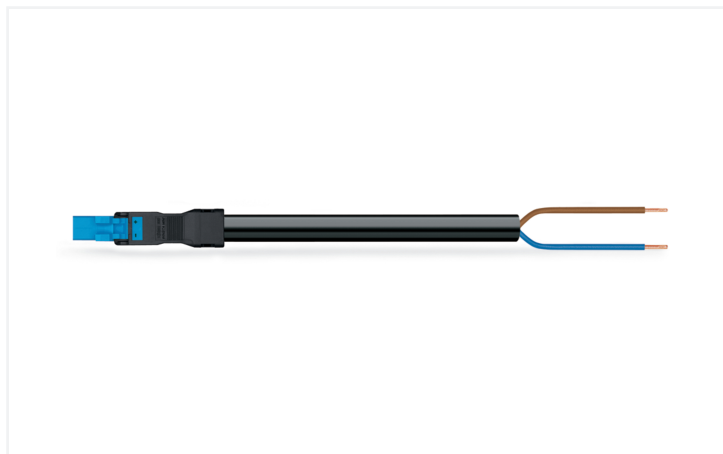

Color: ■ blue

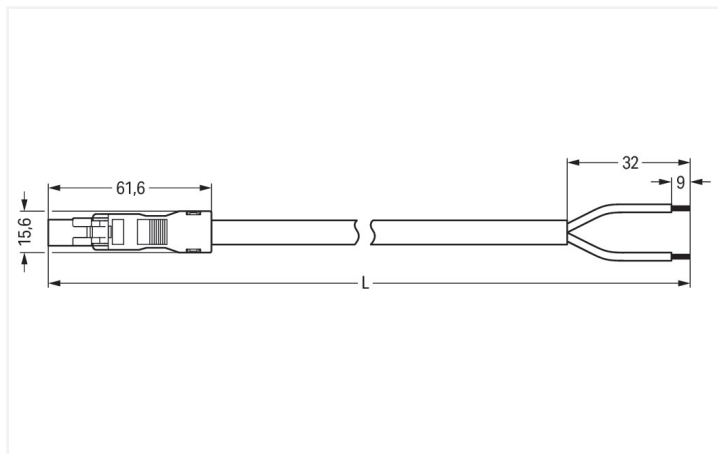

Dimensions in mm

Cable assembly WINSTA® MINI I coding

The WINSTA® MINI cable assembly 2-pole provides the foundation for assembly of fine-stranded and solid conductors. WAGO pluggable installation connectors are used when criteria repeat or are planned on a specified pattern, for example for installing grid lighting or flush-mount lighting. For greater protection in electrical installations, the pluggable installation connector is provided with mechanical protection against mismatching. I coding in blue is used to mark WINSTA® MINI pluggable installation connectors, which are used above all in building automation for activating lighting. WINSTA® MINI follows the trend towards miniaturisation. Our smallest pluggable connection system is especially suitable for lights, for example, since as a result of LED technology; due to complex systems, these offer less and less space for the connection technology. Anyone who needs to worry about technical safety requirements related to fire protection for electrical installation should be able to rely on the quality of the components. Our product satisfies the official safety standards of fire class C. In the manufacturing of this cable assembly, halogens were deliberately omitted. That is an important contribution to environmental protection.

Fast, secure pluggable connections – cable assemblies from WAGO

The cable assembly is provided with a plug and a free end. The WINSTA® Pluggable Connection System is perfectly tailored to the very strict requirements of building installation. It makes electrical installation pluggable, and consequently faster, even more reliable, and error-free. Using this pre-assembled system reduces assembly times and installation errors at the construction site. Now you can also reduce installation costs without compromising safety and quality: with protection type IP20 reduces the need for servicing and prevents unnecessary downtime.

- protection against mismatching eliminates errors
- compact design for conductors with a cross-section up to 1.5 mm²
- with I coding for use in building automation (lighting control)
- custom-engineered solutions
- fast, secure installation

Notes

Note

Cables with a different fire class can be found in the eShop.

Electrical data

Ratings per	IEC/EN 60664-1		
Overvoltage category	III	III	II
Pollution degree	3	2	2
Nominal voltage	250 V	-	-
Rated impulse withstand voltage	4 kV	-	-
Rated current	16 A	-	-

General information

Note on contact resistance	approx. 1 mΩ of contact resistance approx. 0.25 mΩ contact transition plug/ socket
----------------------------	--

Connection Data

Total number of potentials	2
Conductor preparation	ultrasonically tip-bonded

Connection 1

Strip length	9 mm / 0.35 inches
Pole number	2
Wire cross-section	1.5 mm ²
Strip length (outer insulation)	32 mm
Connection type	Plug - free end

Physical data

Pin spacing	4.4 mm / 0.173 inches
Width	15.6 mm / 0.614 inches
Height	13.2 mm / 0.52 inches
Total length	5 m

Mechanical data

Use	DALI, Lighting Management
Coding	I
Variable coding	No
Marking	+ -
Potential marking	+ -
Mating force of a plug-in connection	approx. 20 ... 70 N (depending on pole number)
Retention force of a plug-in connection	when locked: > 80N
Unmating force of a plug-in connection	when unlocked: approx. 20 ... 70 N (depending on pole number)
Number of mating cycles	200, without resistive load
Connection type	Plug - free end
Type of pre-assembled cable	Connecting cable
Cable type	H05Z1Z1-F 2x1.5
Protection type	IP20; IP40 when mated

Plug-in connection

Mismating protection	Yes
Note on mismating protection	All <i>WINSTA</i> ® components are 100% protected against mismating when: a.) plugging different numbers of poles b.) plugging while rotated 180 c.) plugging while laterally staggered d.) plugging one pole
Locking lever	Can be retrofitted
Locking of plug-in connection	Locking lever
Note on locking system	All connectors for mounted installations (snap-in versions for lighting fixtures or devices, all types of PCB and distribution connectors) are factory-equipped with locking levers to ensure plugs and sockets are securely locked. Additional locking levers are only required for flying leads (plug/socket).

Material data

Note (material data)	Information on material specifications can be found here
Color	blue
Insulation material (main housing)	Polyamide (PA66)
Flammability class per UL94	V0
Fire class per EN 50575	C _{ca}
Contact material	Copper or copper alloy; surface-treated
Contact Plating	Tin
Fire load	4.46 MJ
Connector color	blue
Strain relief color	black
Sheathed cable color	black
Printing color of sheathed cable	white
Halogen-free	Yes
Silicon-free	Yes
Sheath material	Halogen-free
Rubber cable	No
Weight	404.4 g
Copper weight of the raw cable	0.029 kg/m

Environmental requirements

Processing temperature	-5 ... +40 °C
Continuous operating temperature	-35 ... +85 °C
Note on continuous operating temperature	Cable for temperatures ≤ 70 °C (including halogen-free) Insulating parts for temperatures ≤ 105 °C

Commercial data

PU (SPU)	1 pcs
Packaging type	unpacked
Country of origin	PL
GTIN	4055143784757
Customs tariff number	85444290900

Product Classification

UNSPSC	26121629
eCl@ss 10.0	27-44-06-04
eCl@ss 9.0	27-44-06-04
ETIM 9.0	EC002587
ETIM 10.0	EC002587
ECCN	NO US CLASSIFICATION

Environmental Product Compliance

RoHS Compliance Status	Compliant, No Exemption
------------------------	-------------------------

Downloads

Environmental Product Compliance

Compliance Search

Environmental Product
Compliance
891-8382/266-501



1 Compatible Products

1.1 Required Accessories

1.1.1 Locking system

1.1.1.1 Locking system



[Item No.: 890-111](#)

Locking lever; for flying leads; for tool operation; black



[Item No.: 890-131](#)

Locking lever; for flying leads; for tool operation; white



[Item No.: 890-101](#)

Locking lever; for manual operation; black



[Item No.: 890-121](#)

Locking lever; for manual operation; white

1.2 Optional Accessories

1.2.1 Cover

1.2.1.1 Cover



[Item No.: 897-2001](#)

Protective cap; Type1; for sockets and plugs; PVC; red

1.2.2 Installation

1.2.2.1 Mounting accessories



[Item No.: 890-310](#)

Mounting carrier; 2- to 5-pole; for flying leads; black



[Item No.: 890-311](#)

Mounting carrier; 2- to 5-pole; for flying leads; white