

Color: ■ light gray

Similar to illustration

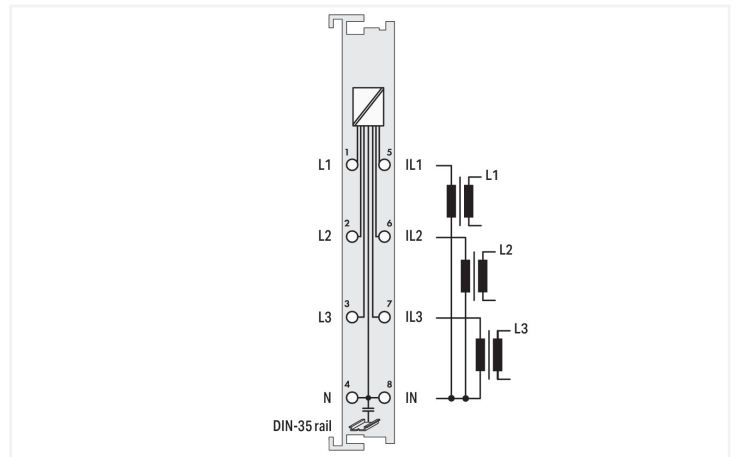
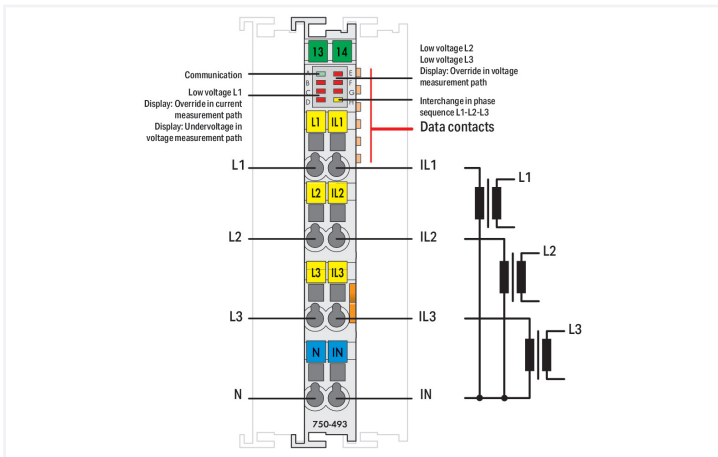

The 3-phase power measurement module measures electrical data in a three-phase supply network.

The voltage is measured via network connection to clamping points L1, L2, L3 and N.

The current of the three phases is fed to IL1, IL2, IL3, and IN via current transformers.

The 3-phase power measurement module transmits the root mean square values into the process image without requiring high computing power from the controller. For each phase, the effective power (P) and the energy consumption (W) are calculated by the 3-phase power measurement module using the root mean square values for all measured voltages (V) and currents (I). For example, both the apparent power (S) and phase shift angle (ϕ) can be easily derived from these values.

Therefore, the 3-phase power measurement module provides comprehensive network analysis via fieldbus. Metrics, such as effective and apparent power consumption or load condition, enable the operator to optimize supply to a drive or machine. This can protect the installation from damage and failure.

Technical data

Number of measurement inputs	6 (3 voltage measurement inputs, 3 current measurement inputs)
Signal type	Power measurement
Input voltage (max.)	Current Inputs: 18 VAC
Signal form	Any (taking the maximum frequency into account)
Resolution [bit]	16 bits
Data width	2 x 48-bit data; 2 x 24-bit control/status (optional)
Voltage path input resistance (typ.)	1071 kΩ
Current path input resistance (typ.)	22 mΩ
Reference for measurement error	AC current/voltage
Measurement error (reference temperature)	25 °C
Measurement error, deviation (max.) from the upper-range value	0.6 %
Measurement current (max.)	1 A
Measurement cycle time	Adjustable measuring cycle time for Min_Max_Values
Frequency range with activated DC filter	10 ... 2000 Hz
Frequency range with deactivated DC filter	0 ... 2000 Hz
Frequency range (mains frequency)	45 ... 65 Hz
Limit frequency	7.2 kHz
Rated Voltage	$U_{LN} = 277 \text{ VAC}$; $U_{LL} = 480 \text{ VAC}$
Calculated values	Active power, active energy, grid frequency, $\cos \varphi$
Measurement components	Evaluating
Measurement method	True RMS measurement
Supply voltage (system)	5 VDC; via data contacts
Current consumption (5 V system supply)	100 mA
Isolation	4 kV system/field
Rated impulse withstand voltage	4 kV
Indicators	LED (A) green: Communication; LED (B-G) red: Error L1, Override in Current Measurement Path (display), Undervoltage in Voltage Measurement Path (display), Error L2, Error L3, Override in Voltage Measurement Path (display); LED (H) yellow: Interchange in Phase Sequence L1-L2-L3

Connection Data

Connection technology: I/O	8 x CAGE CLAMP®
Connectable conductor materials	Copper
Connection type	Inputs/outputs
Solid conductor	0.08 ... 2.5 mm ² / 28 ... 14 AWG
Fine-stranded conductor	0.08 ... 2.5 mm ² / 28 ... 14 AWG
Strip length	8 ... 9 mm / 0.31 ... 0.35 inches

Physical data

Width	12 mm / 0.472 inches
Height	100 mm / 3.937 inches
Depth	67.8 mm / 2.669 inches
Depth from upper-edge of DIN-rail	60.6 mm / 2.386 inches

Mechanical data

Mounting type	DIN-35 rail
---------------	-------------

Material data

Color	light gray
Housing material	Polycarbonate; polyamide 6.6
Fire load	0.661 MJ
Weight	50 g
Conformity marking	CE

Environmental requirements

Ambient temperature (operation)	-20 ... +60 °C
Ambient temperature (storage)	-40 ... +85 °C
Protection type	IP20
Pollution degree	2 per IEC 61131-2
Operating altitude	0 ... 2000 m / 0 ... 6562 ft
Mounting position	Horizontal left, horizontal right, horizontal top, horizontal bottom, vertical top and vertical bottom
Relative humidity (without condensation)	95 %
Relative humidity (with condensation)	Short-term condensation per Class 3K6/IEC EN 60721-3-3 and E-DIN 40046-721-3, accounting for a temperature range of -20 to +60 °C (except for wind-driven precipitation, water and ice formation)
Vibration resistance	Per IEC 60068-2-6
Shock resistance	15g per IEC 60068-2-27
EMC immunity to interference	per EN 61000-6-2
EMC emission of interference	per EN 61000-6-3
Exposure to pollutants	per IEC 60068-2-42 and IEC 60068-2-43
Permissible H ₂ S contaminant concentration at a relative humidity 75 %	10 ppm
Permissible SO ₂ contaminant concentration at a relative humidity 75 %	25 ppm

Commercial data

Product Group	15 (I/O System)
PU (SPU)	1 pcs
Packaging type	Box
Country of origin	DE
GTIN	4055143085878
Customs tariff number	85389099990

Product Classification

UNSPSC	41113630
eCl@ss 10.0	27-24-26-05
eCl@ss 9.0	27-24-26-05
ETIM 9.0	EC001596
ETIM 10.0	EC001596
ECCN	NO US CLASSIFICATION

Environmental Product Compliance	
CAS-No.	1303-86-2 1317-36-8 7439-92-1
REACH Candidate List Substance	Diboron trioxide Lead Lead monoxide
RoHS Compliance Status	Compliant,With Exemption
RoHS Exemption	6(c) 7(a) 7(c)-I 7(c)-II
SCIP notification number (Bulgaria)	b35ccf26-dba6-4768-848a-b7ea225df002
SCIP notification number (Czech Republic)	5bbe0e9a-9c23-4846-a126-def206043955

Approvals / Certificates

General approvals			Approvals for hazardous areas		
Approval	Standard	Certificate Name	Approval	Standard	Certificate Name
EAC GZO Almaty Standart	TP TC 020/2011	EAC CoC 03083	ATEX TUEV Nord Cert GmbH	EN 60079-0	TUEV14ATEX148929X (II 3 G Ex ec IIC T4 Gc)
KC National Radio Research Agency	Article 58-2, Clause 3	MSIP-REM-W43-AIM750	CCCEX CQST/CNEX	CNCA-C23-01	2020312310000213 (Ex ec IIC T4 Gc)
UL Underwriters Laboratories Inc. (ORDINARY LOCATIONS)	UL 508	E175199	IECEX TUEV Nord Cert GmbH	IEC 60079-0	IECEX TUN 14.0035 X (Ex ec IIC T4 Gc)
			INMETRO TUV Rheinland do Brasil Ltda.	IEC 60079-0	TUV 12.1297 X
			UKEX WAGO GmbH & Co. KG	EN 60079-0	UKCA_WA GO22UKEX003X_ec
			UL Underwriters Laboratories Inc. (HAZARDOUS LOCATIONS)	UL 121201	E198726

Downloads

Environmental Product Compliance	
Compliance Search	
Environmental Product Compliance 750-493/025-000	↓

Documentation

Manual		System Description	
Product Manual 3-Phase Power Measurement Module	V 1.3.0 05.09.2024 pdf 3132.65 KB	750/753 Series I/O-System – General Product Information	pdf 953.35 KB
System Manual Series 750/753	↓	Overview on WAGO-I/O-SYSTEM 750 approvals	pdf 770.48 KB

Bid Text			
750-493/025-000	19.02.2019	xml 5.96 KB	↓
750-493/025-000	26.06.2019	docx 18.14 KB	↓

Instruction Leaflet			
CCC Ex (Additional information)	26.04.2023	pdf 159.76 KB	↓

Application Notes

Application note SIEMENS			
Using 3-Phase Power Measurement Module 750-493 or 750-493/000-001 with TIA (a117651)	1.0.1 10.01.2017	zip 6149.52 KB	↓

CAD/CAE-Data

CAD data	
2D/3D Models 750-493/025-000	↓

CAE data	
EPLAN Data Portal 750-493/025-000	↓
WSCAD Universe 750-493/025-000	↓

Runtime Software

Firmware			
0750-0493, 3-Phasen-Leistungsmessung	V 05 07.06.2022	zip 158.48 KB	↓

1 Compatible Products

1.1 Optional Accessories

1.1.1 Current transformer

1.1.1.1 Current transformer terminal block



Item No.: 2007-8873
Compact terminal block; for current and voltage transformers; 6,00 mm²; multicoloured

Item No.: 2007-8875
Compact terminal block; for current transformer circuit; 6,00 mm²; multicoloured

1.1.1.2 Plug-in current transformer



Item No.: 855-1700/032-000
Plug-in current transformer; Primary rated current 32 A; Secondary rated current 320 mA

Item No.: 855-301/100-201
Plug-in current transformer; Primary rated current: 100 A; Secondary rated current: 1 A; Rated power: 2.5 VA; Accuracy class: 1

Item No.: 855-501/1000-1001
Plug-in current transformer; Primary rated current: 1000 A; Secondary rated current: 1 A; Rated power: 10 VA; Accuracy class: 1

Item No.: 855-801/1000-1001
Plug-in current transformer; Primary rated current: 1000 A; Secondary rated current: 1 A; Rated power: 10 VA; Accuracy class: 1

1.1.1.2 Plug-in current transformer



Item No.: 855-301/150-501
 Plug-in current transformer; Primary rated current: 150 A; Secondary rated current: 1 A; Rated power: 5 VA; Accuracy class: 1



Item No.: 855-601/1500-501
 Plug-in current transformer; Primary rated current: 1500 A; Secondary rated current: 1 A; Rated power: 5 VA; Accuracy class: 1



Item No.: 855-301/200-501
 Plug-in current transformer; Primary rated current: 200 A; Secondary rated current: 1 A; Rated power: 5 VA; Accuracy class: 1



Item No.: 855-801/2000-1001
 Plug-in current transformer; Primary rated current: 2000 A; Secondary rated current: 1 A; Rated power: 10 VA; Accuracy class: 1



Item No.: 855-301/250-501
 Plug-in current transformer; Primary rated current: 250 A; Secondary rated current: 1 A; Rated power: 5 VA; Accuracy class: 1



Item No.: 855-401/250-501
 Plug-in current transformer; Primary rated current: 250 A; Secondary rated current: 1 A; Rated power: 5 VA; Accuracy class: 1



Item No.: 855-1001/2500-1001
 Plug-in current transformer; Primary rated current: 2500 A; Secondary rated current: 1 A; Rated power: 10 VA; Accuracy class: 1



Item No.: 855-2701/035-001
 Plug-in current transformer; Primary rated current: 35 A; Secondary rated current: 1 A; Rated power: 0.2 VA; Accuracy class: 1



Item No.: 855-301/400-1001
 Plug-in current transformer; Primary rated current: 400 A; Secondary rated current: 1 A; Rated power: 10 VA; Accuracy class: 1



Item No.: 855-501/400-1001
 Plug-in current transformer; Primary rated current: 400 A; Secondary rated current: 1 A; Rated power: 10 VA; Accuracy class: 1



Item No.: 855-401/400-501
 Plug-in current transformer; Primary rated current: 400 A; Secondary rated current: 1 A; Rated power: 5 VA; Accuracy class: 1



Item No.: 855-301/050-103
 Plug-in current transformer; Primary rated current: 50 A; Secondary rated current: 1 A; Rated power: 1.25 VA; Accuracy class: 3



Item No.: 855-301/060-101
 Plug-in current transformer; Primary rated current: 60 A; Secondary rated current: 1 A; Rated power: 1.25 VA; Accuracy class: 1



Item No.: 855-301/600-1001
 Plug-in current transformer; Primary rated current: 600 A; Secondary rated current: 1 A; Rated power: 10 VA; Accuracy class: 1



Item No.: 855-401/600-501
 Plug-in current transformer; Primary rated current: 600 A; Secondary rated current: 1 A; Rated power: 10 VA; Accuracy class: 1



Item No.: 855-501/600-1001
 Plug-in current transformer; Primary rated current: 600 A; Secondary rated current: 1 A; Rated power: 10 VA; Accuracy class: 1



Item No.: 855-2701/064-001
 Plug-in current transformer; Primary rated current: 64 A; Secondary rated current: 1 A; Rated power: 0.2 VA; Accuracy class: 1



Item No.: 855-301/075-201
 Plug-in current transformer; Primary rated current: 75 A; Secondary rated current: 1 A; Rated power: 2.5 VA; Accuracy class: 1



Item No.: 855-501/800-1001
 Plug-in current transformer; Primary rated current: 800 A; Secondary rated current: 1 A; Rated power: 10 VA; Accuracy class: 1

1.1.1.3 Split-core current transformer



Item No.: 855-4001/100-001
 Split-core current transformer; Primary rated current: 100 A; Secondary rated current: 1 A; Rated power: 0.2 VA; Accuracy class: 1; Cable length: 3 m



Item No.: 855-3001/100-003
 Split-core current transformer; Primary rated current: 100 A; Secondary rated current: 1 A; Rated power: 0.2 VA; Accuracy class: 3; Cable length: 3 m



Item No.: 855-5001/1000-000
 Split-core current transformer; Primary rated current: 1000 A; Secondary rated current: 1 A; Rated power: 0.5 VA; Accuracy class: 0.5; Cable length: 5 m



Item No.: 855-5101/1000-000
 Split-core current transformer; Primary rated current: 1000 A; Secondary rated current: 1 A; Rated power: 0.5 VA; Accuracy class: 0.5; Cable length: 5 m



Item No.: 855-4001/150-001
 Split-core current transformer; Primary rated current: 150 A; Secondary rated current: 1 A; Rated power: 0.2 VA; Accuracy class: 1; Cable length: 3 m



Item No.: 855-4001/200-001
 Split-core current transformer; Primary rated current: 200 A; Secondary rated current: 1 A; Rated power: 0.2 VA; Accuracy class: 0.5; Cable length: 3 m



Item No.: 855-3001/200-001
 Split-core current transformer; Primary rated current: 200 A; Secondary rated current: 1 A; Rated power: 0.2 VA; Accuracy class: 1; Cable length: 3 m



Item No.: 855-4101/200-001
 Split-core current transformer; Primary rated current: 200 A; Secondary rated current: 1 A; Rated power: 0.2 VA; Accuracy class: 1; Cable length: 3 m



Item No.: 855-3001/250-001
 Split-core current transformer; Primary rated current: 250 A; Secondary rated current: 1 A; Rated power: 0.2 VA; Accuracy class: 1; Cable length: 3 m



Item No.: 855-4101/250-001
 Split-core current transformer; Primary rated current: 250 A; Secondary rated current: 1 A; Rated power: 0.2 VA; Accuracy class: 1; Cable length: 3 m



Item No.: 855-5001/250-001
 Split-core current transformer; Primary rated current: 250 A; Secondary rated current: 1 A; Rated power: 0.5 VA; Accuracy class: 1; Cable length: 5 m



Item No.: 855-4101/400-001
 Split-core current transformer; Primary rated current: 400 A; Secondary rated current: 1 A; Rated power: 0.2 VA; Accuracy class: 1; Cable length: 3 m



Item No.: 855-5001/400-000
 Split-core current transformer; Primary rated current: 400 A; Secondary rated current: 1 A; Rated power: 0.5 VA; Accuracy class: 0.5; Cable length: 5 m



Item No.: 855-3001/060-003
 Split-core current transformer; Primary rated current: 60 A; Secondary rated current: 1 A; Rated power: 0.2 VA; Accuracy class: 3; Cable length: 3 m



Item No.: 855-5001/600-000
 Split-core current transformer; Primary rated current: 600 A; Secondary rated current: 1 A; Rated power: 0.5 VA; Accuracy class: 0.5; Cable length: 5 m

1.1.2 DIN-rail

1.1.2.1 Mounting accessories



Item No.: 210-196

Aluminum carrier rail; 35 x 8.2 mm; 1.6 mm thick; 2 m long; unslotted; similar to EN 60715; silver-colored



Item No.: 210-198

Copper carrier rail; 35 x 15 mm; 2.3 mm thick; 2 m long; unslotted; according to EN 60715; copper-colored



Item No.: 210-197

Steel carrier rail; 35 x 15 mm; 1.5 mm thick; 2 m long; slotted; similar to EN 60715; silver-colored



Item No.: 210-114

Steel carrier rail; 35 x 15 mm; 1.5 mm thick; 2 m long; unslotted; similar to EN 60715; silver-colored



Item No.: 210-118

Steel carrier rail; 35 x 15 mm; 2.3 mm thick; 2 m long; unslotted; according to EN 60715; silver-colored



Item No.: 210-112

Steel carrier rail; 35 x 7.5 mm; 1 mm thick; 2 m long; slotted; according to EN 60715; "Hole width 25 mm; silver-colored



Item No.: 210-113

Steel carrier rail; 35 x 7.5 mm; 1 mm thick; 2 m long; unslotted; according to EN 60715; silver-colored

1.1.3 Marking

1.1.3.1 Group marker carrier



Item No.: 750-107

Group marker carrier

1.1.3.2 Marker



Item No.: 2009-145/000-006

Mini-WSB In-line; for Smart Printer; 1700 pieces on roll; stretchable 5 - 5.2 mm; plain; snap-on type; blue



Item No.: 2009-145/000-007

Mini-WSB In-line; for Smart Printer; 1700 pieces on roll; stretchable 5 - 5.2 mm; plain; snap-on type; gray



Item No.: 2009-145/000-023

Mini-WSB In-line; for Smart Printer; 1700 pieces on roll; stretchable 5 - 5.2 mm; plain; snap-on type; green



Item No.: 2009-145/000-012

Mini-WSB In-line; for Smart Printer; 1700 pieces on roll; stretchable 5 - 5.2 mm; plain; snap-on type; orange



Item No.: 2009-145/000-005

Mini-WSB In-line; for Smart Printer; 1700 pieces on roll; stretchable 5 - 5.2 mm; plain; snap-on type; red



Item No.: 2009-145/000-024

Mini-WSB In-line; for Smart Printer; 1700 pieces on roll; stretchable 5 - 5.2 mm; plain; snap-on type; violet



Item No.: 2009-145

Mini-WSB In-line; for Smart Printer; 1700 pieces on roll; stretchable 5 - 5.2 mm; plain; snap-on type; white



Item No.: 2009-145/000-002

Mini-WSB In-line; for Smart Printer; 1700 pieces on roll; stretchable 5 - 5.2 mm; plain; snap-on type; yellow



Item No.: 248-501/000-006

Mini-WSB marking card; as card; not stretchable; plain; snap-on type; blue



Item No.: 248-501/000-007

Mini-WSB marking card; as card; not stretchable; plain; snap-on type; gray



Item No.: 248-501/000-023

Mini-WSB marking card; as card; not stretchable; plain; snap-on type; green



Item No.: 248-501/000-017

Mini-WSB marking card; as card; not stretchable; plain; snap-on type; light green



Item No.: 248-501/000-012

Mini-WSB marking card; as card; not stretchable; plain; snap-on type; orange



Item No.: 248-501/000-005

Mini-WSB marking card; as card; not stretchable; plain; snap-on type; red



Item No.: 248-501/000-024

Mini-WSB marking card; as card; not stretchable; plain; snap-on type; violet



Item No.: 248-501

Mini-WSB marking card; as card; not stretchable; plain; snap-on type; white



Item No.: 248-501/000-002

Mini-WSB marking card; as card; not stretchable; plain; snap-on type; yellow

1.1.3.3 Marker carrier



Item No.: 750-103

Group marker carrier

1.1.4 Potential distribution

1.1.4.1 Current and voltage tap



Item No.: 855-951/250-000

Current and voltage tap up to 95 mm²; Primary rated current: 250 A; Secondary rated current: 1 A; Rated power: 0.2 VA; Accuracy class: 0.5; fused

1.1.5 Power tap

1.1.5.1 Power tap



Item No.: 855-8003

Power tap; with fuse; 10 mm² (8 AWG) - 16 mm² (6 AWG); Phase



Item No.: 855-8001

Power tap; with fuse; 2,5 mm² (12 AWG) - 6 mm² (10 AWG); Phase



Item No.: 855-8004

Power tap; without fuse; 10 mm² (8 AWG) - 16 mm² (6 AWG); N-conductor



Item No.: 855-8002

Power tap; without fuse; 2,5 mm² (12 AWG) - 6 mm² (10 AWG); N-conductor

1.1.6 Shield termination

1.1.6.1 Shield clamping saddles



Item No.: 790-108

Shield clamping saddle; 11 mm wide; diameter of compatible conductor; 3 ... 8 mm



Item No.: 790-208

Shield clamping saddle; 12.4 mm wide; 3 ... 8 mm



Item No.: 790-116

Shield clamping saddle; 19 mm wide; diameter of compatible conductor; 7 ... 16 mm



Item No.: 790-216

Shield clamping saddle; 21.8 mm wide; 6 ... 16 mm



Item No.: 790-124

Shield clamping saddle; 27 mm wide; diameter of compatible conductor; 6 ... 24 mm



Item No.: 790-220

Shield clamping saddle; 30 mm wide; 6 ... 20 mm



Item No.: 790-140

Shield clamping saddle; diameter of compatible conductor

1.1.7 System enclosure

1.1.7.1 System enclosure



Item No.: 850-825

IP65 enclosure; Aluminium (RAL 7032); WxHxD (160x100x160 mm); 9 x M12, 4 x M20



Item No.: 850-826

IP65 enclosure; Aluminium (RAL 7032); WxHxD (240x100x160 mm); 4 x M20, 4 x M16, 14 x M12 cable grip



Item No.: 850-827

IP65 enclosure; Aluminium (RAL 7032); WxHxD (320x100x160 mm); 4 x M20, 8 x M16, 17 x M12 cable grip



Item No.: 850-828

IP65 enclosure; Aluminium (RAL 7032); WxHxD (480x100x160 mm); 4 x M20, 10 x M16, 35 x M12 cable grip



Item No.: 850-826/002-000

IP65 enclosure; Aluminium (RAL 7035); WxHxD (240x100x160 mm); 4 x M20, 4 x M16, 14 x M12 cable grip



Item No.: 850-827/002-000

IP65 enclosure; Aluminium (RAL 7035); WxHxD (320x100x160 mm); 4 x M20, 8 x M16, 17 x M12 cable grip



Item No.: 850-828/002-000

IP65 enclosure; Aluminium (RAL 7035); WxHxD (480x100x160 mm); 4 x M20, 10 x M16, 35 x M12 cable grip



Item No.: 850-834

IP65 enclosure; Polyester (RAL 7032); WxHxD (164x100x164 mm); 9 x M12, 4 x M20

1.1.7.1 System enclosure



Item No.: 850-835

IP65 enclosure; Polyester (RAL 7032); WxHxD (244x100x164 mm); 4 x M20, 4 x M16, 14 x M12 cable grip



Item No.: 850-836

IP65 enclosure; Polyester (RAL 7032); WxHxD (324x100x164 mm); 4 x M20, 8 x M16, 17 x M12 cable grip



Item No.: 850-814/002-000

IP65 enclosure; Sheet steel (RAL 7035); WxHxD (200x120x200 mm); without flange plate



Item No.: 850-815/002-000

IP65 enclosure; Sheet steel (RAL 7035); WxHxD (300x120x200 mm); without flange plate



Item No.: 850-816/002-000

IP65 enclosure; Sheet steel (RAL 7035); WxHxD (400x120x200 mm); without flange plate



Item No.: 850-817/002-000

IP65 enclosure; Sheet steel (RAL 7035); WxHxD (600x120x200 mm); without flange plate