

EMAX2 E4.2 MS/DC-E LOW VOLTAGE AIR SWITCH-DISCONNECTORS

SACE Emax 2

Installation, operation and maintenance instructions
for the installer and the user



Glossary	3
References	4
1 - ABB documentation mentioned in this manual	4
Emax E4.2 circuit-breakers	5
1 - Contents.....	5
2 - Safety.....	6
3 - Regulations	7
Management operations	8
1 - Transport and checking on receipt.....	8
2 - Unpacking and handling.....	11
3 - Description.....	14
4 - Environmental conditions	25
5 - Installation.....	25
Accessories	33
1 - Overview.....	33
2 - Wiring diagrams.....	34
Putting into service and maintenance	38
1 - Putting into service.....	38
2 - Identification of alarms or failures	42
3 - Maintenance.....	44
4 - First level maintenance.....	46
5 - Second level maintenance.....	50
6 - Decommissioning and treatment at end of life.....	59

Glossary

Term	Description
SACE Emax 2 DC	New series of ABB SACE air switch disconnectors
4P	Disconnector configurations: four-pole (4P)

References

1 - ABB documentation mentioned in this manual

Consult the following documents mentioned in this manual for further information about the topics covered:

Operating instructions for the design engineer



[1SDH001330R1002](#)

Technical catalog



[1SDC200023D0906](#)

Anti-insertion lock



[1SDH001000R0701](#)

ABB Library Download Center



[DOWNLOADCENTER](#)

Emax 2 Products



[EMAX 2 PRODUCTS](#)

Emax E4.2 circuit-breakers

1 - Contents

Overview This manual contains instructions on the operations to be performed on Emax E4.2 circuit-breakers throughout their life cycle, from reception to installation, and from commissioning to subsequent maintenance during operation, with particular attention to the environment at the end of the life cycle of the product.

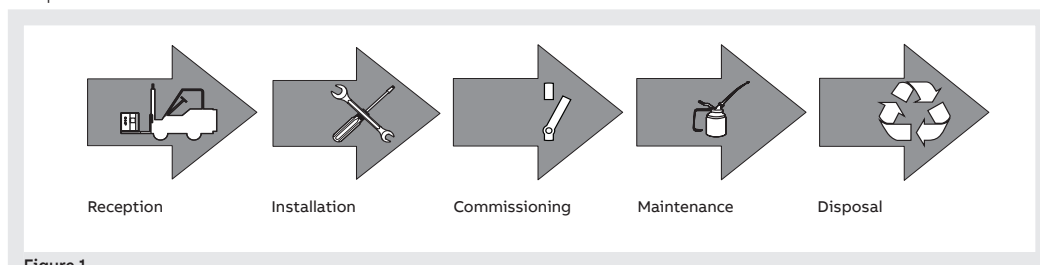

Figure 1

Integrated informations The full description of the Emax 2 family is available in document [1SDH001330R1002](#) (Emax 2 engineering manual) available on the website ABB library.



recipients

This manual refers to two user profiles, as defined by standard IEC 60050:

- Electrically Skilled Person (IEV 195-04-01): person with relevant education and experience to enable him or her to perceive risks and to avoid hazards which electricity can create.
- Trained Persons in the electrical field (IEV 195-04-02): person adequately advised or supervised by electrically skilled persons to enable him or her to perceive risks and to avoid danger which electricity can create.



IMPORTANT: This manual specifically indicates what operations can be performed by people trained in the field of electricity. All the remaining operations described in the handbook must be performed by skilled persons, in the electrical field. ABB declines all liability for damage to persons or property caused by failure to comply with the instructions in this document.

Specifications and supporting documents

To ensure that the Emax 2 circuit-breaker is installed and configured correctly, please read the information in this manual and in the technical documentation of the product, supplied with the circuit-breaker or available in the website [ABB LIBRARY](#)

Document	Description
1SDC200023D0906	Sace Emax 2 CBs General catalog
1SDM000017A1001	Circuit diagrams of disconnectors Sace Emax 2 MS/DC-E
1SDC200013D0201	Technical catalog "SACE Emax 2 MS/DC-E"

Design notes

The information in this manual was written in Italian and then translated into other languages to conform to the laws and/or commercial requirements concerning the product.

2 - Safety

Warnings

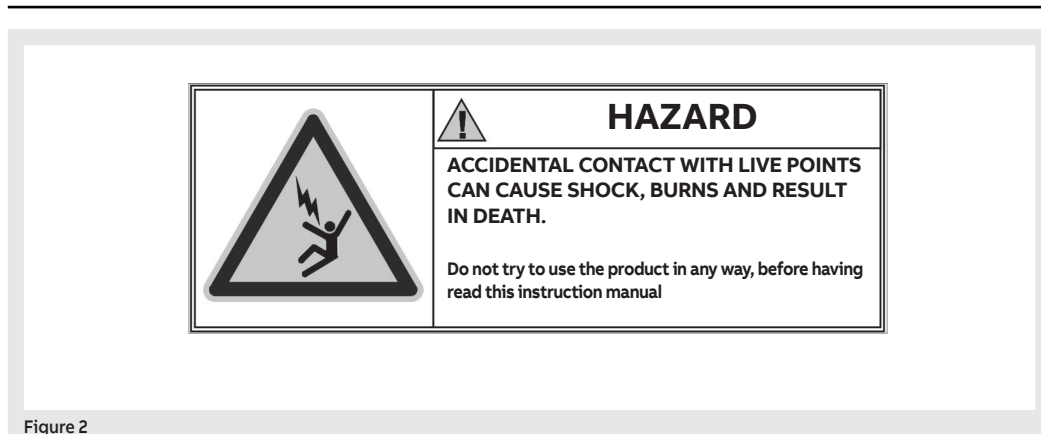

Figure 2

The following warnings must be respected:

- **READ THE INSTRUCTION MANUAL CAREFULLY BEFORE ATTEMPTING TO INSTALL, OPERATE OR REPAIR THE CIRCUIT-BREAKER/DISCONNECTOR.**
- store these instructions along with other documents for instruction, maintenance and installation, drawings and descriptive notes on the circuit-breaker;
- keep these documents available during the installation, operation and maintenance of the appliance. The use of these instructions facilitates proper maintenance;
- install the circuit-breaker within the limits of the project described in the instruction manual shipped with the unit. These circuit-breakers are designed to operate with values of voltage and current within the limits of plate ratings. Do not install this equipment in systems operating at nominal values exceeding these limits;
- follow the safety procedures indicated by Your Company;
- do not open any covers or doors, do not work on devices before removing power from all circuits, and after making sure of that with a measuring instrument.

WARNING!

- detailed descriptions of standard procedures for installation, use, maintenance and principles for safe operation are not included. It is important to note that this document contains safety and precaution instructions, against certain methods (of installation, use and maintenance) that could cause harm to personnel, damage devices, or make them unsafe;
- these warnings and alarms do not include all conceivable ways to make installation, use and maintenance recommended by ABB or not, that may be made, or possible consequences and complications of each conceivable way, nor shall ABB investigate all those ways;
- anyone using maintenance procedures or devices, recommended by ABB or not, must check thoroughly that neither personal safety nor the safety devices are endangered by mode of installation, use, maintenance or the instruments used. For more information, questions or specific problems contact your nearest ABB representative;
- this manual is addressed to qualified personnel only and is not intended to replace an adequate training course or experience concerning the safety procedures of this device;
- for the products equipped with communication, the purchaser, the installer or the final customer is responsible for applying all the IT safety measures necessary in order to prevent risks deriving from connection to communication networks; such risks include, among other things, the use of the product by unauthorized persons, alteration of its normal functionality, accessing and modifying the information;
- the purchaser, installer or end user is responsible for ensuring that notices and safety signs are posted and that all access points and switching devices are locked securely when the switchgear is left unattended, even momentarily;
- all the information contained in this document reflects the latest product information available at the time of printing. We reserve the right to edit the document at any time and without notice

3 - Regulations

Standards Sace Emax 2 MS/DC-E series circuit-breakers conform to international standards:

- IEC 60947-3
- EN 60947-3
- UL 489F
- UL 489B
- GB/T 14048.3

They comply with the following EC directives:

- "Low Voltage Directive" (LVD) n° 2014/35/EU
 - "Electromagnetic Compatibility Directive" (EMC) n° 2014/30/EU
-

Management operations

1 - Transport and checking on receipt

Introduction In view of their weight, Sace Emax 2/MS 1500 V DC series switch disconnectors require particular care during transport and handling.

They are distributed with following packages:

- one package for fixed circuit-breaker
- two packages for withdrawable circuit-breakers (one package for the fixed part and one for the mobile part).



WARNING! comply with the following instructions during each transport phase:

- **The movable part of the circuit-breaker must be removed from the switchgear and/or from the relative fixed part even if this latter is not installed in the switchgear.**
- **The circuit-breaker must be in the open position.**
- **The circuit-breaker must be protected and fastened in its original packing.**
- **The closing springs of the circuit-breaker must be completely discharged.**

Weight of the circuit-breakers with packaging

The following table specifies the weights of the circuit-breakers with packaging:

Standards	Current	Configuration	Fixed 4p		Withdrawable 4p		Fixed part 4p	
			Kg	Lbs	Kg	Lbs	Kg	Lbs
IEC 60947-3	4000A	4ps	120	265	80	176	97	214
	3200A		120	265			97	214
	2500A		105	231			81	179
	2000A		105	231			81	179
	1600A		105	231			81	179
	4000A	2ps	114	252			90	198
	3200A		114	252			90	198
	2500A		104	229			79	174
	2000A		104	229			79	174
	1600A		104	229			79	174
UL 489B	3200A	4ps	132 (*)	292 (*)	108 (*)	238 (*)		
		2ps	140 (*)	308 (*)	115 (*)	254 (*)		
UL 489B UL 489F	2500A	4ps	132 (*)	292 (*)	108 (*)	238 (*)		
	2000A		119	262	94	207		
	1600A		119	262	94	207		
	2500A	2ps	140 (*)	308 (*)	115 (*)	254 (*)		
	2000A		115	253	88	194		
1600A	115	253	88	194				

(*) Terminals supplied not assembled



NOTE:

- the indicated weights refer to fixed circuit-breakers with rear terminals without accessories.
- the weights of the fixed part refer to the version with vertical rear terminals and, if present, with jumpers.

Transport of the packaged circuit-breaker

Consult the table "Weight of the circuit-breakers with packaging" before proceeding with the transport.



DANGER! improper lifting can result in death, serious injury to persons and damage to the equipment. Never lift a circuit-breaker and/or a fixed part above other people.



IMPORTANT: the qualified personnel tasked with handling and lifting work must use suitable safety equipment.

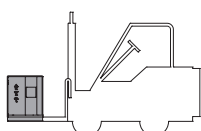

Identification of packaging

Examine the state of the packaging and check that:

- the data on the packaging plate match the data of the order;
- the box is intact and perfectly closed.

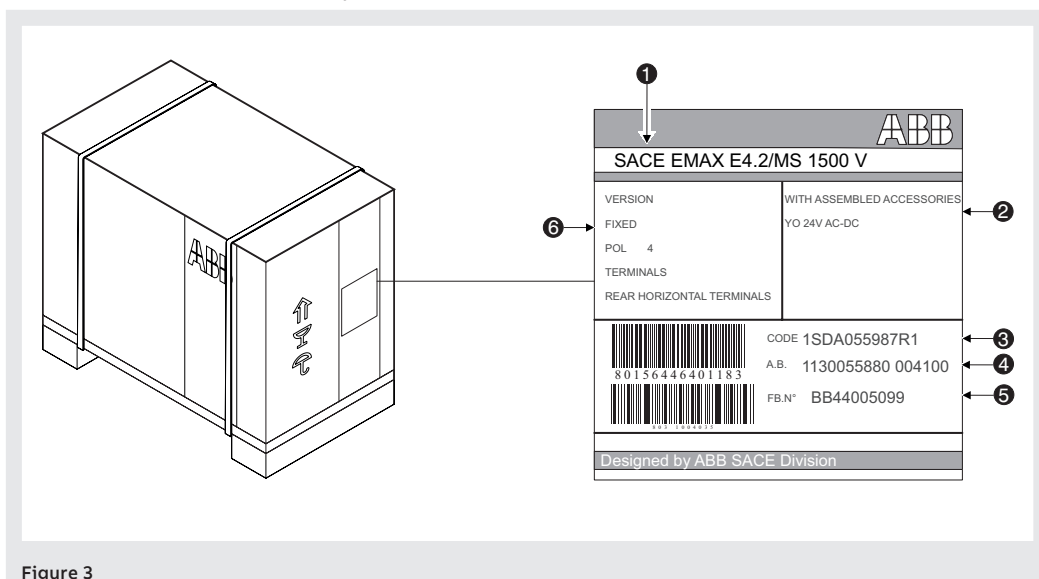

Figure 3

Pos.	Description
1	Brief description of disconnecter
2	Description of accessories
3	Commercial code
4	Confirmation number and location
5	Disconnecter serial number
6	Features of the circuit-breaker

Inspection of packaging

Examine the state of the material received and verify that:

- The circuit-breaker or the fixed part are consistent with the order.
- The circuit-breaker or the fixed part are completely intact.



IMPORTANT:

- **If the material is to be stored, check it beforehand. For opening the packaging, follow the procedures outlined in the section "Unpacking and handling - opening the packages" on page 11**
- **In the case of any inconsistencies, report them within five days of reception. See the paragraph "Damage and Discrepancy Report" in this chapter.**

Damage and Discrepancy Report

If there is any damage to the packaging upon receipt and / or inconsistencies between order and product identification label or product please contact ABB. Damage to the packaging must be reported no later than seven days from receipt of the material.



NOTE: The notification must indicate the Packing List number.

Storage method

Place the packaging (circuit-breakers and / or fixed parts) on a horizontal plane, not in contact with the floor. If the circuit-breaker has been removed and reinserted in the package ensure, prior to storage that:

- The circuit-breaker is in the open position and the springs are discharged. See the paragraph Manual operations for opening and closing the circuit-breaker on page 18.
- The circuit-breaker is protected and locked in its original packaging

⚠ WARNING! stack up to three packages of E4.2 circuit-breakers. If the package has been opened, stacking is allowed as long as the package is re-wrapped as it was originally.

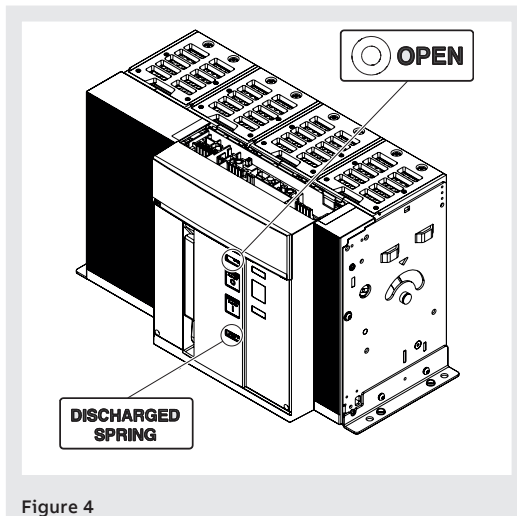

Figure 4

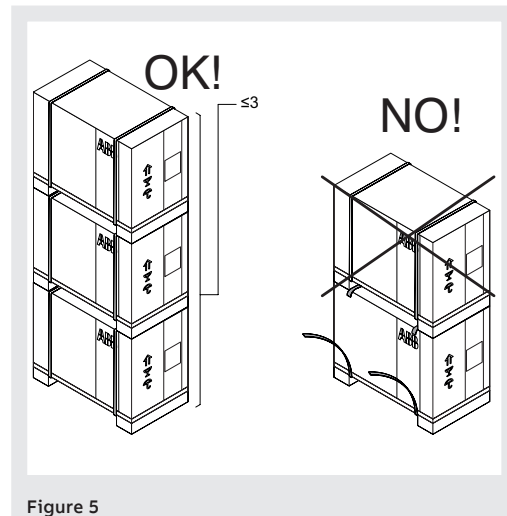

Figure 5

⚠ WARNING! If the package with the terminals is joined to that of the circuit-breaker (UL 2500A-3200A) additional packages cannot be stacked on top.

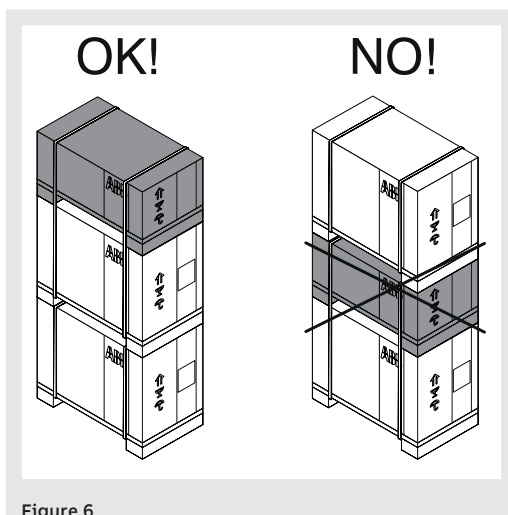

Figure 6

2 - Unpacking and handling

Opening the packaging



NOTE: consult the instruction sheet in the pocket applied to the package in order to unpack in conditions of safety.

The following is the procedure for opening the packaging:

1. Cut the bands that wrap the packing box. See Figure 7 and Figure 8.

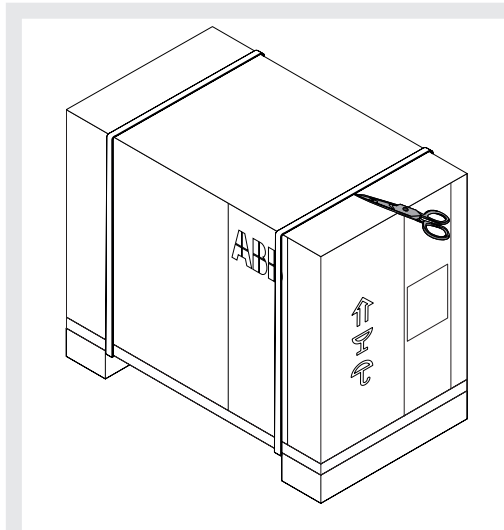

Figure 7

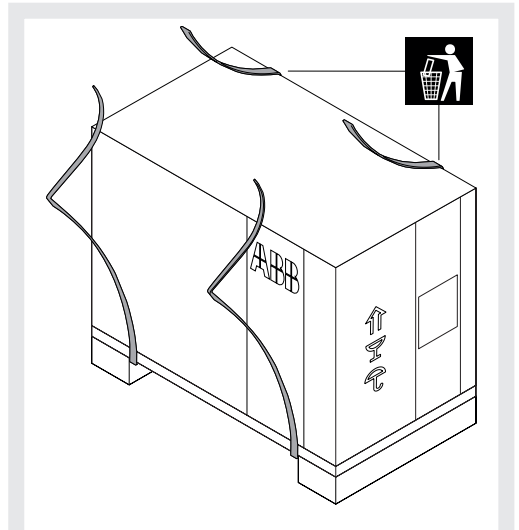

Figure 8

2. Open the upper part of the packing box. See Figure 9.
3. Remove the packing box by lifting it upwards. See Figure 10.

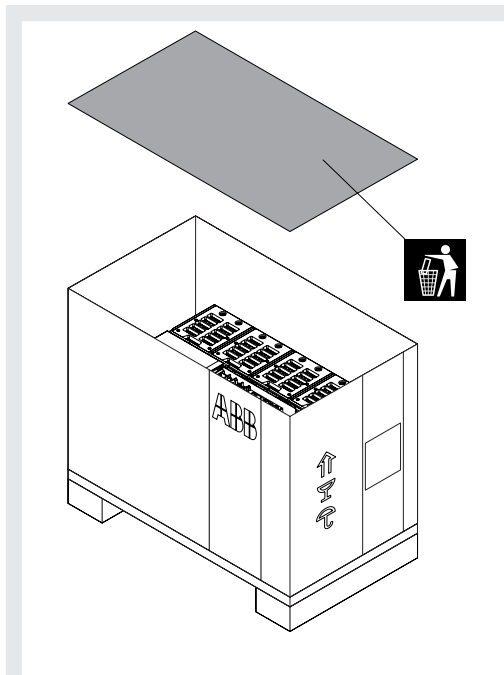

Figure 9

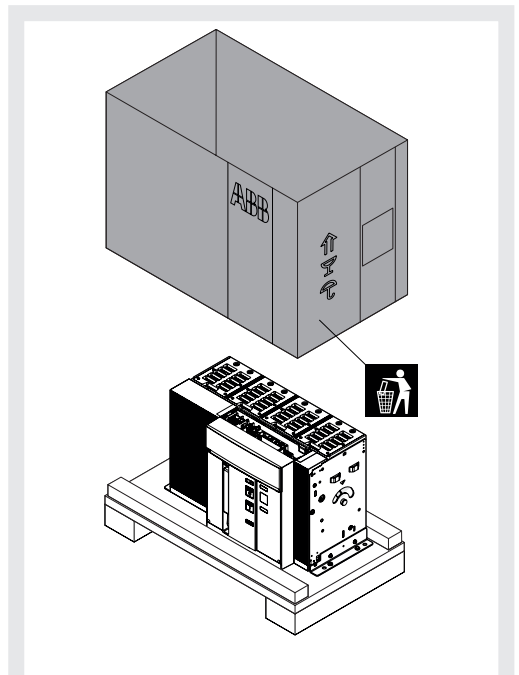

Figure 10

Continued on the next page

4. Take out the screws (see Figure 11 Fixed circuit-breaker). Take out the screws and the mounting brackets (see Figure 12 Moving part, Figure 13 Fixed part).

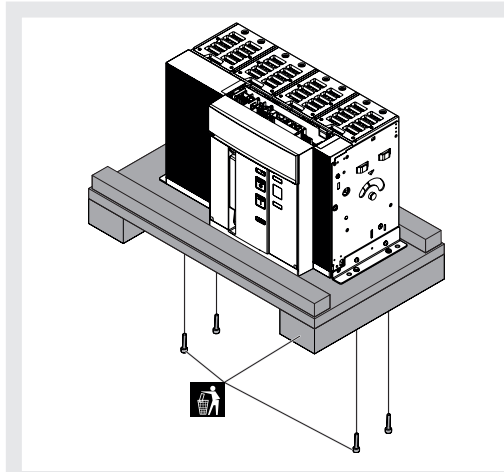

Figure 11 Fixed circuit-breaker

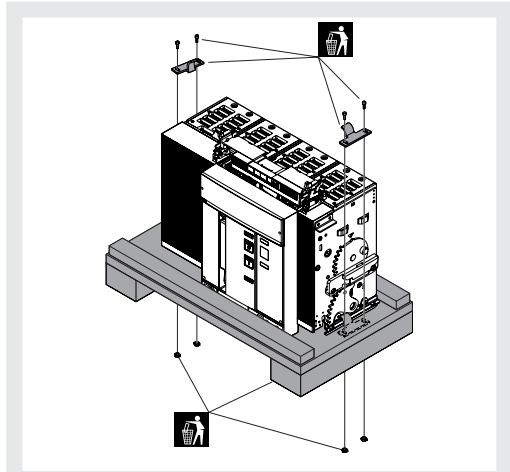

Figure 12 Moving part

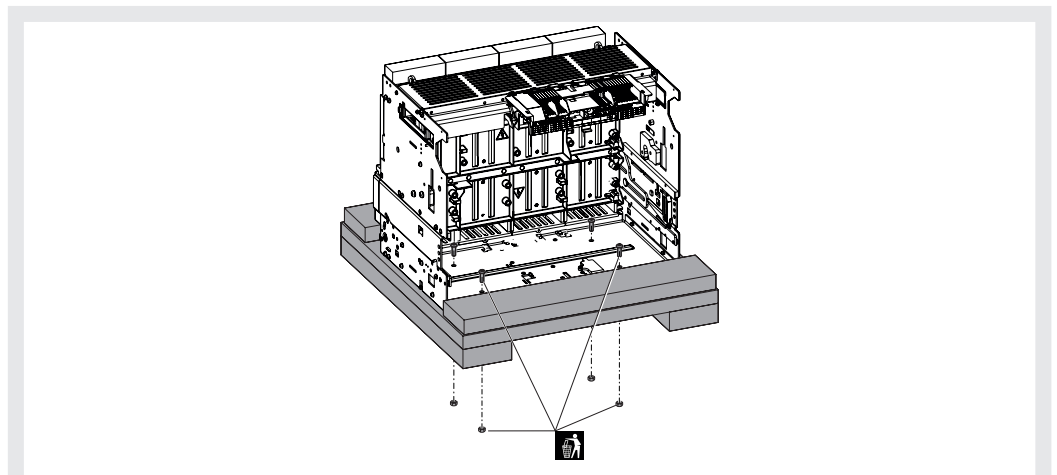

Figure 13 Fixed part

Disposal of the packaging materials

For disposal of the packaging materials see the chapter " 6 - Decommissioning and treatment at end of life " on page 59.

Weight of circuit-breakers without packaging

The following table specifies the weights of the circuit-breakers without packaging:

Standards	Current	Configuration	Fixed 4p		Withdrawable 4p		Fixed part 4p	
			Kg	Lbs	Kg	Lbs	Kg	Lbs
IEC 60947-3	4000A	4ps	110	243	80	176	87	192
	3200A		110	243			87	192
	2500A		95	209			71	157
	2000A		95	209			71	157
	1600A		95	209			71	157
	4000A	2ps	104	230			80	176
	3200A		104	230			80	176
	2500A		94	207			69	152
	2000A		94	207			69	152
	1600A		94	207			69	152

Continued on the next page

Standards	Current	Configuration	Fixed 4p		Withdrawable 4p		Fixed part 4p			
			Kg	Lbs	Kg	Lbs	Kg	Lbs		
UL 489B	3200A	4ps	122 (*)	270 (*)	80	176	98 (*)	216 (*)		
		2ps	130 (*)	286 (*)			105 (*)	232 (*)		
UL 489B	2500A	4ps	122 (*)	270 (*)			80	176	98 (*)	216 (*)
	2000A		109	240					84	185
	1600A		109	240					84	185
UL 489F	2500A	2ps	130 (*)	286 (*)			80	176	105 (*)	232 (*)
	2000A		105	231	78	172				
	1600A		105	231	78	172				

^(*) Terminals supplied not assembled



NOTE:

- the indicated weights refer to fixed circuit-breakers with rear terminals without accessories.
- the weights of the fixed part refer to the version with vertical rear terminals and, if present, with jumpers.

Lift the fixed circuit breaker or the moving part of a withdrawable circuit-breaker



DANGER! Improper lifting can result in death, serious injury to persons and damage to the equipment. Never lift a circuit-breaker and / or a fixed part above other people.



IMPORTANT: The trained personnel in charge of handling and lifting must use appropriate safety equipment.

To lift the fixed circuit-breaker or moving part of withdrawable device:

1. Raise the circuit-breaker from the base of the packaging with the aid of the lifting plates supplied with the circuit-breaker. See Figure 14 and Figure 15.

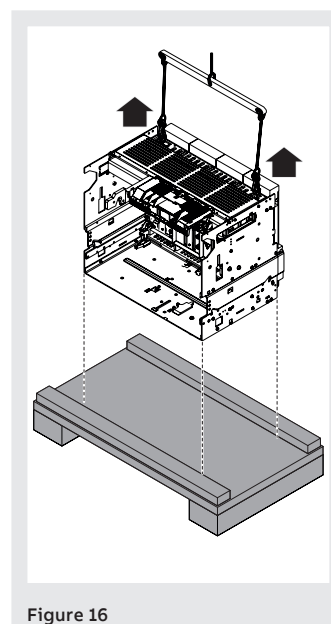
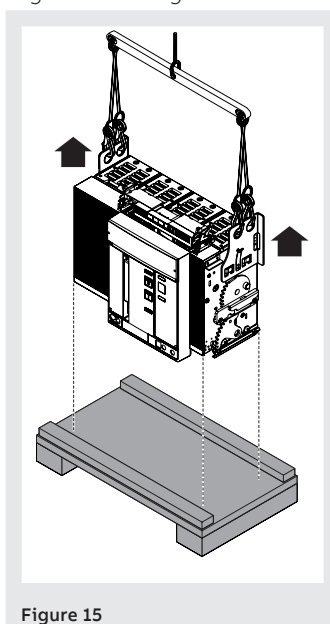
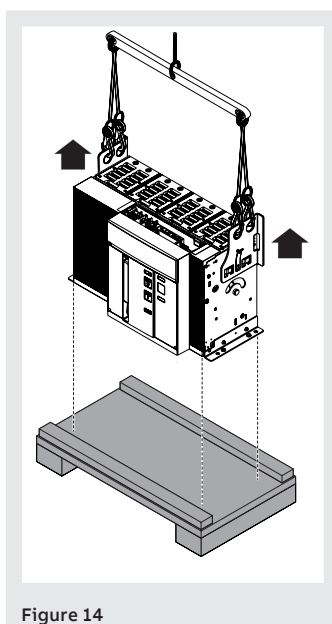

To raise the fixed part of the circuit-breaker

1. Lift the fixed part from the base of the package using the purpose-made lifting points of the fixed part. See Figure 16.



IMPORTANT: keep the lifting plates and manual until the disconnecter is dismantled.

3 - Description

Description of switch disconnect

Emax E4.2 circuit-breakers consist of a steel structure which houses the operating mechanism, the poles and the auxiliary parts.

Each pole, insulated from the others, contains the breaking parts.

It is available in two types:

- fixed version
- withdrawable

The fixed version circuit-breaker has its own terminals for connection to the power circuit (Figure 17).

The withdrawable version consists of a movable part (Figure 18) and by a fixed part for connection to the power circuit by its own terminals (Figure 19).

The moving and fixed parts are coupled together by special clamps installed on the movable part.

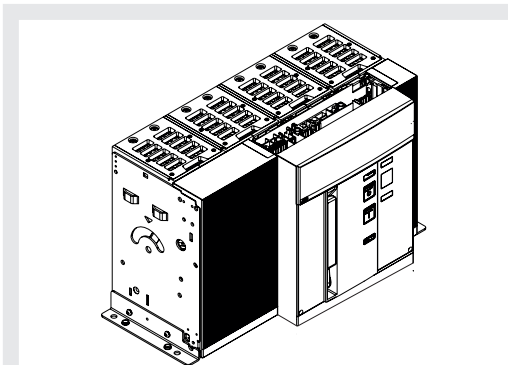

Figure 17

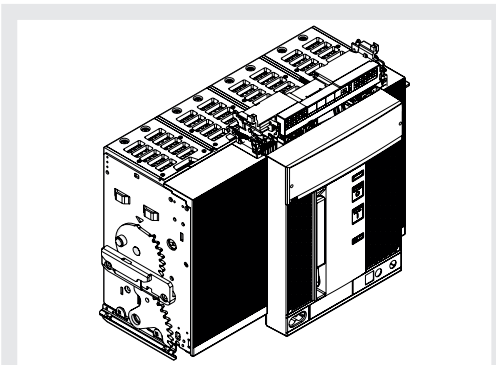

Figure 18

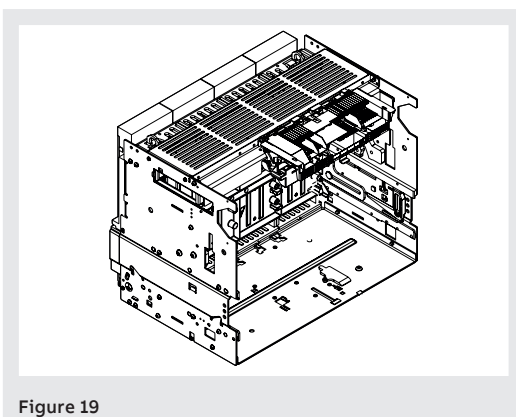

Figure 19

Front description The following are the main components of the circuit-breaker:

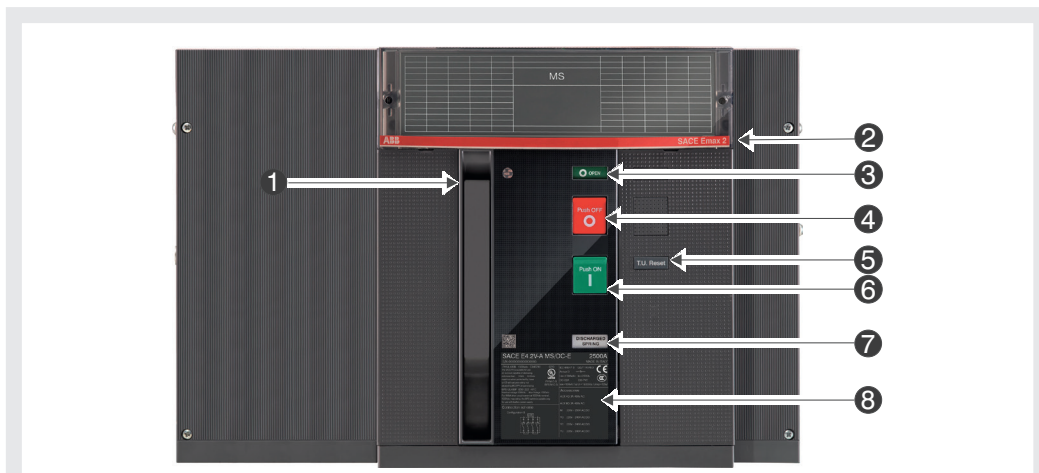

Figure 20

Pos.	Description
1	Lever for manually charging the closing springs
2	Name of the circuit-breaker
3	CB open (O) / closed (I) indicator
4	Opening pushbutton
5	Mechanical signalling of tripped TU
6	Closing pushbutton
7	Springs charged-discharged signalling device
8	Electrical data plate

Description of IEC+CCC specification data plate

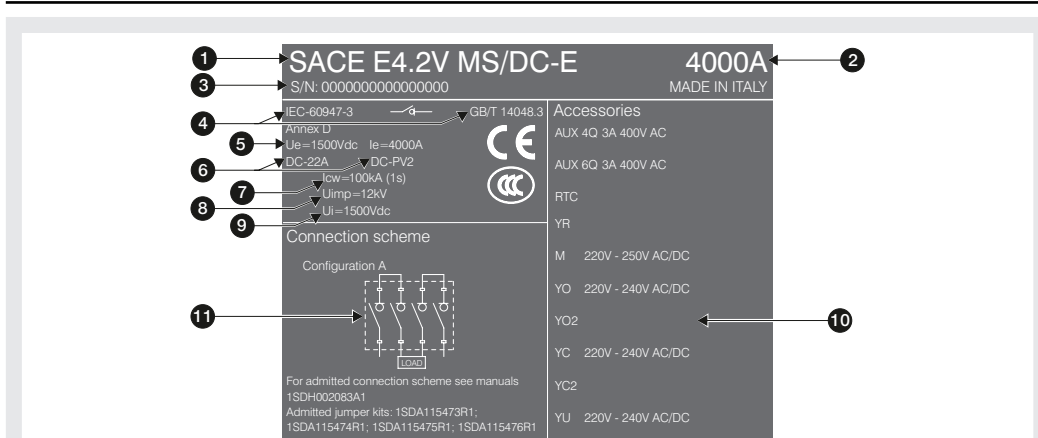

Figure 21

Pos.	Description
1	Type of circuit-breaker
2	Rated current
3	Circuit-breaker serial number
4	Standards
5	Rated service voltage
6	Utilization category
7	Admissible rated short-time current
8	Impulse voltage
9	Insulation voltage
10	Rated voltage of accessories
11	Circuit diagram (if present)

Description of UL+IEC specification data plate

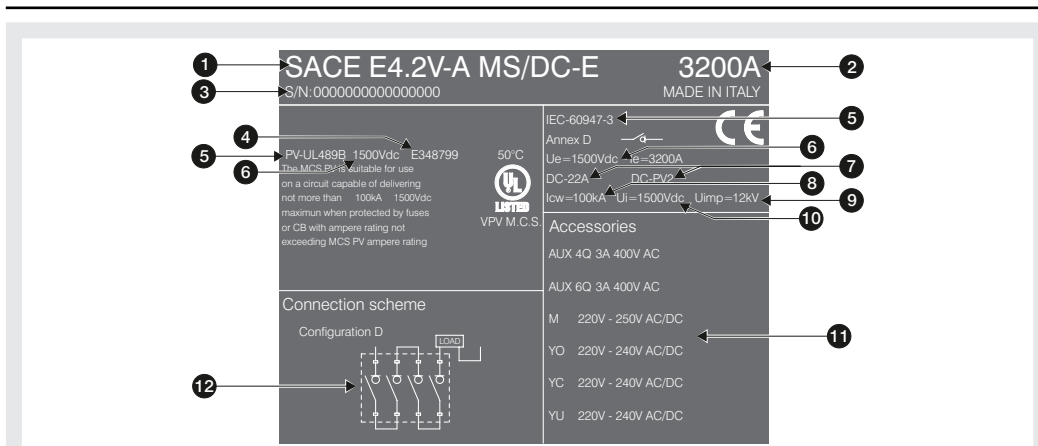

Figure 22

Pos.	Description
1	Type of circuit-breaker
2	Rated current
3	Circuit-breaker serial number
4	UL file number
5	Standards
6	Rated service voltage
7	Utilization category
8	Admissible rated short-time current
9	Impulse voltage
10	Insulation voltage
11	Rated voltage of accessories
12	Circuit diagram

Description of UL+IEC+CCC specification data plate

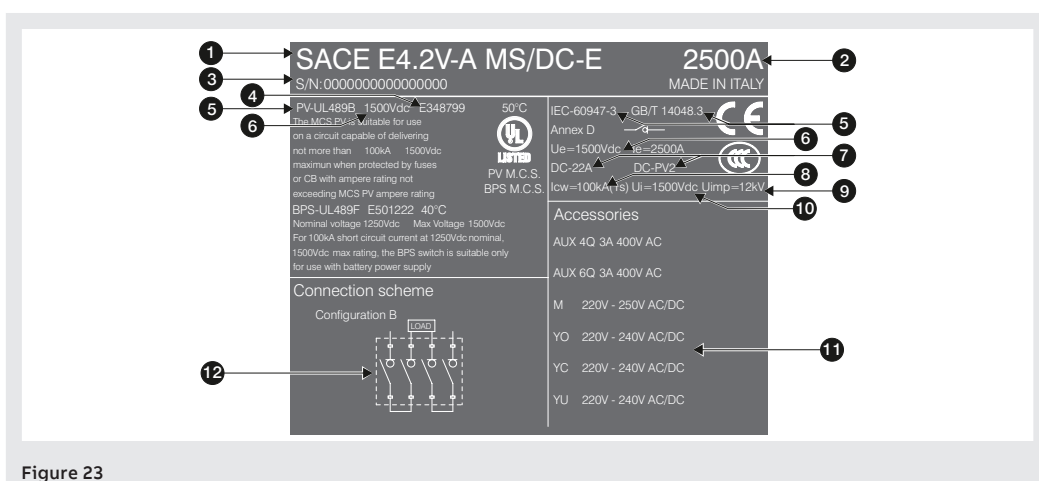

Figure 23

Pos.	Description
1	Type of circuit-breaker
2	Rated current
3	Circuit-breaker serial number
4	UL file number
5	Standards
6	Rated service voltage
7	Utilization category
8	Admissible rated short-time current
9	Impulse voltage
10	Insulation voltage
11	Rated voltage of accessories
12	Circuit diagram

Manual operations for opening and closing the circuit-breaker

The following is the sequence of steps for closing and opening the circuit-breaker:

1. Check that the circuit-breaker is open (open / closed indicator "O - OPEN"), and check that the springs are discharged (spring signalling device "white - DISCHARGED SPRING") as indicated in Figure 24.
2. Charging the springs - Pull the lever [A] downwards several times until the springs charged signalling device [B] is "yellow - CHARGED SPRING" as indicated in Figure 25.

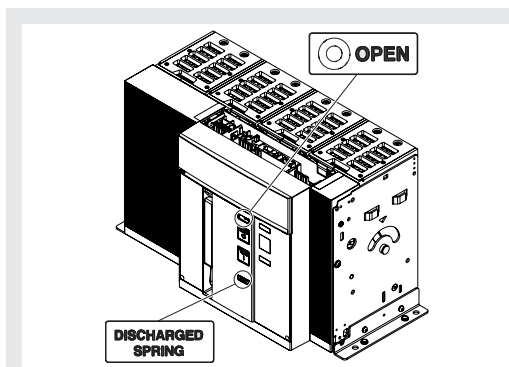

Figure 24

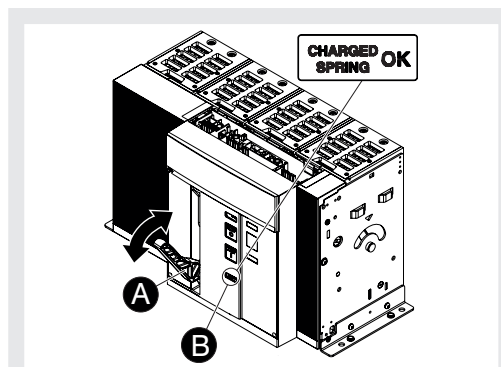

Figure 25

3. Check that the circuit-breaker is open (open/closed signalling device "O - OPEN"), and check that the springs are charged (springs signalling device "yellow - CHARGED SPRING") as indicated in Figure 26.
4. Closing - Press the closing pushbutton "I - Push ON" as indicated in Figure 27.

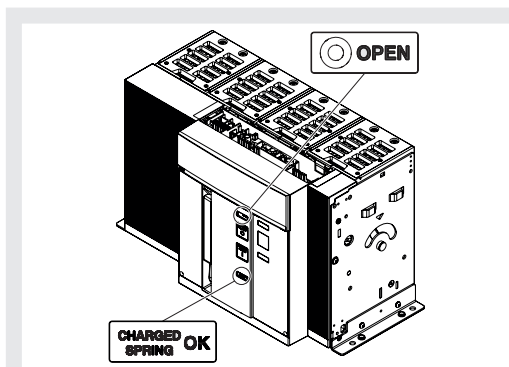

Figure 26

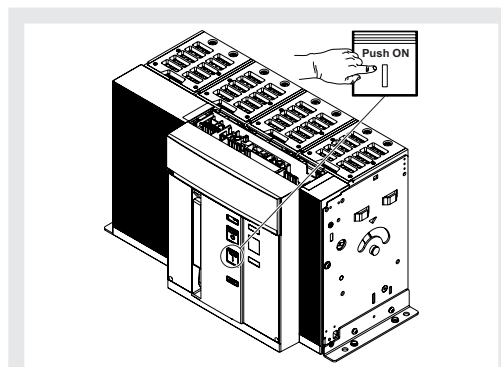

Figure 27

5. Check that the circuit-breaker is closed (open/closed indicator "I - CLOSED"), and check that the springs are discharged (spring signalling device "white - DISCHARGED SPRING") as indicated in Figure 28.
6. Opening - Press the opening pushbutton "O - Push OFF" as indicated in Figure 29.

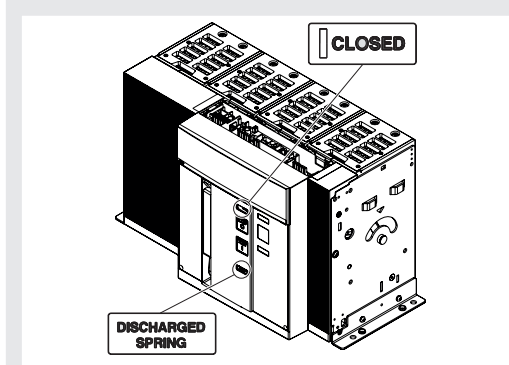

Figure 28

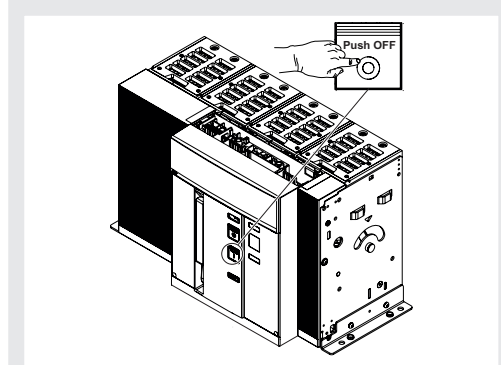

Figure 29

Continued on the next page

7. Check that the circuit-breaker is open (open / closed indicator "O - OPEN"), and check that the springs are discharged (spring signalling device "white - DISCHARGED SPRING") as indicated in Figure 30.

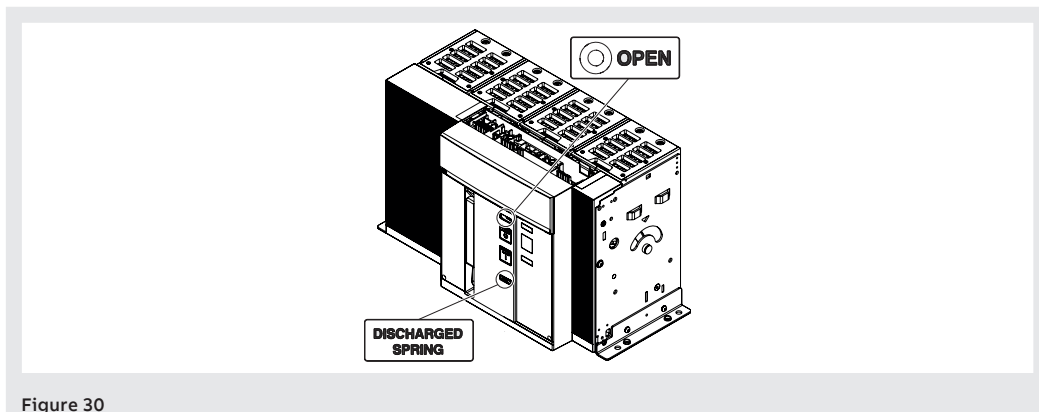

Figure 30

Mechanical status indicators

The following are the possible states in which you can find the circuit-breaker:

1. Circuit-breaker open with springs discharged (see Figure 31).
2. Circuit-breaker open with springs charged (see Figure 32).
3. Circuit-breaker closed with springs discharged (see Figure 33).
4. Circuit-breaker closed with springs charged and not ready to close (see Figure 34). This state occurs when after closing (see step 4 - Manual operations for opening and closing the circuit-breaker) the springs are recharged manually or automatically by the gearmotor (if provided).
5. Circuit-breaker open with springs charged and not ready to close (see Figure 35). This state occurs in the following cases:
 - The key lock or padlock is active in the open position.
 - The undervoltage coil is de-energized
 - The opening coil is permanently energized.
 - The closing coil is permanently energized.
 - The pushbutton for enabling the insertion/extraction crank of a withdrawable circuit-breaker is pressed.

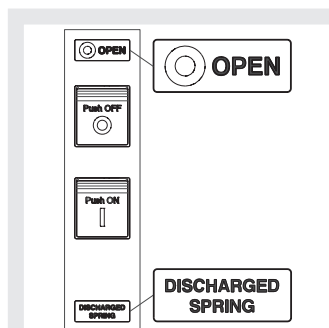

Figure 31

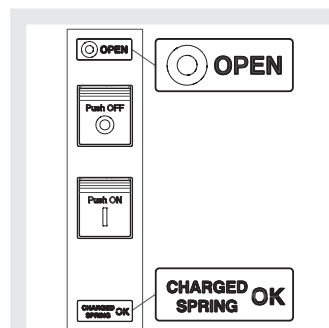

Figure 32

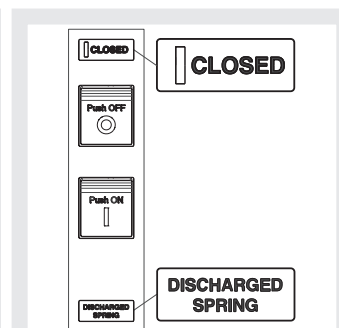

Figure 33

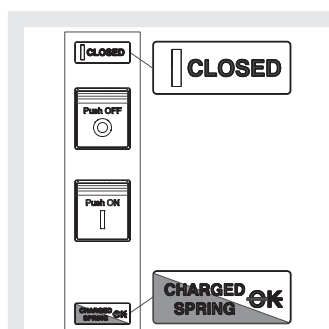

Figure 34

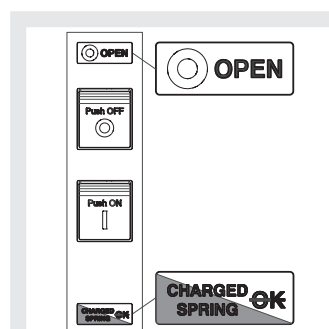

Figure 35

Circuit breaker racking-in/ racking-out operations

The following is the procedure for the insertion of the moving part in the fixed part:



WARNING!

- Make sure the circuit-breaker is disconnected from all sources of energy.
- Switch the circuit-breaker to the open position with springs discharged.



WARNING! Before proceeding, remove all equipment used during the work and remove processing waste and materials used.

1. Turn plate through 90° before inserting the moving part.
2. Extract the guides of the fixed part using the appropriate levers. See Figure 36.

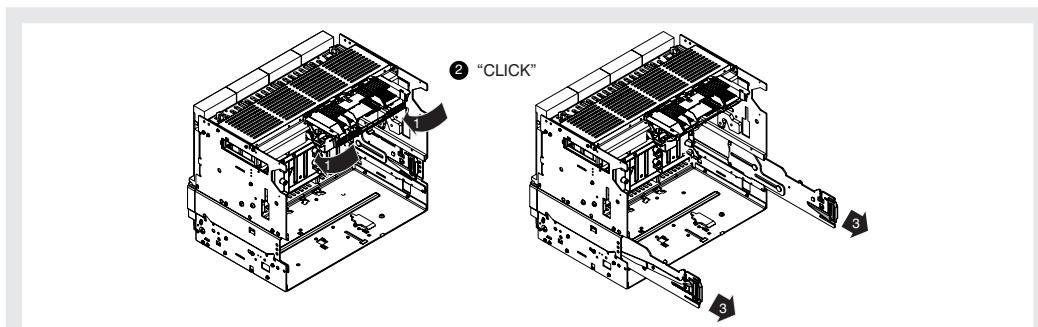

Figure 36

3. Position the lifting plates on the mobile part making sure that the tongue of the plates is latched properly. See Figure 37.

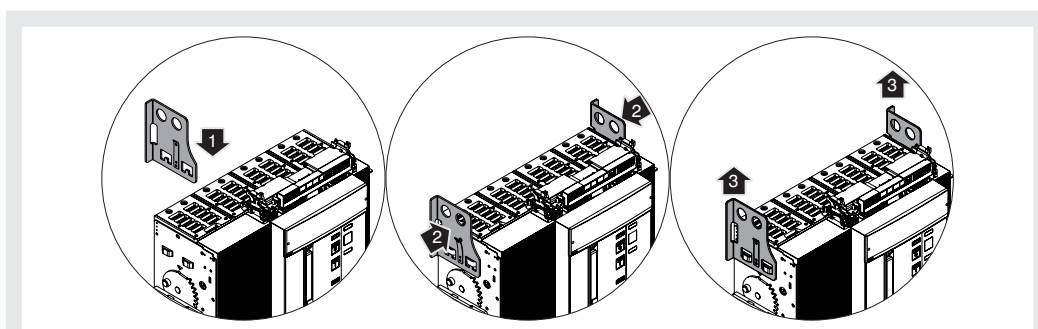

Figure 37

4. Position the moving part on the guides of the fixed part. Latch by inserting the hollow part of the side in the latch of the guide of the fixed part See Figure 38.

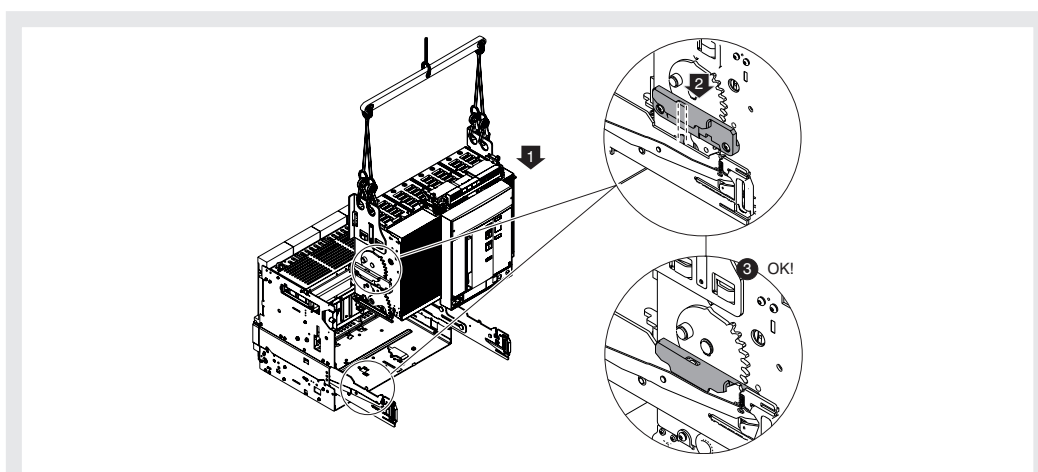

Figure 38

Continued on the next page

- 5. Unlatch the tongue and remove the lifting plates from the moving part. See Figure 39.

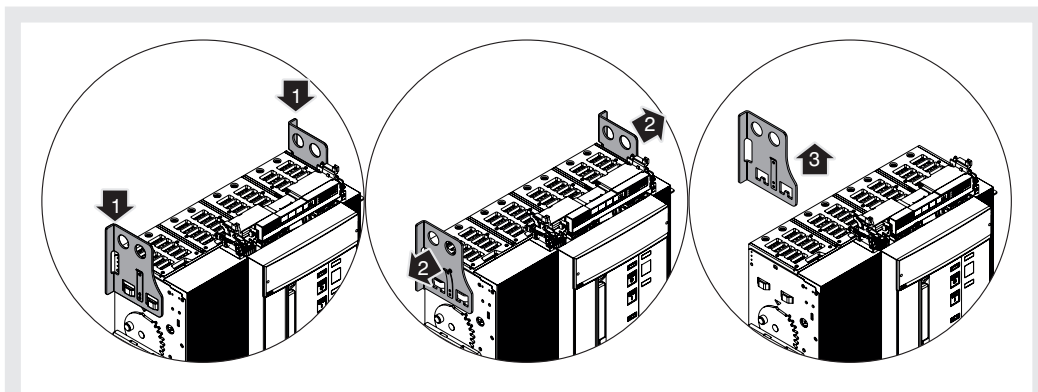

Figure 39

- 6. Make sure that the signalling device indicates the **DISCONNECT** position. See Figure 40.

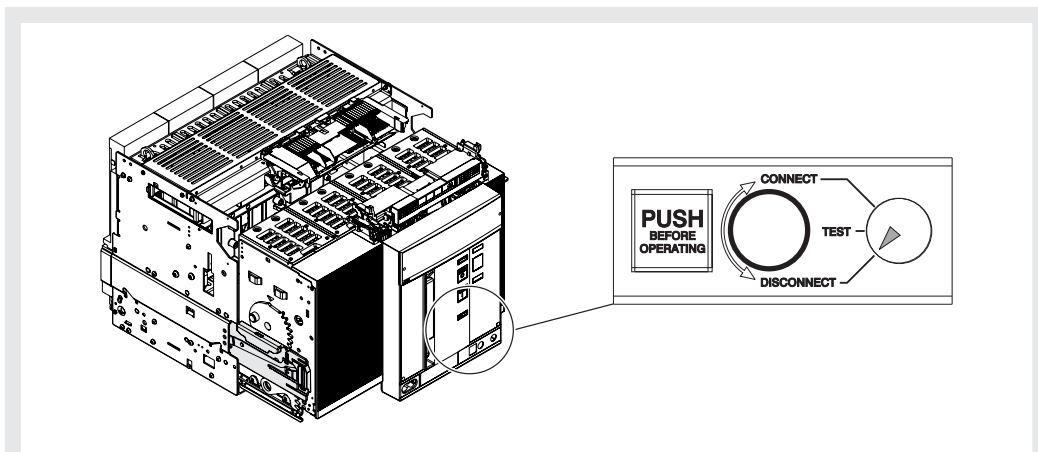

Figure 40

- 7. Grip the guide levers of the fixed part and push them until the moving part stops. See Figure 41.

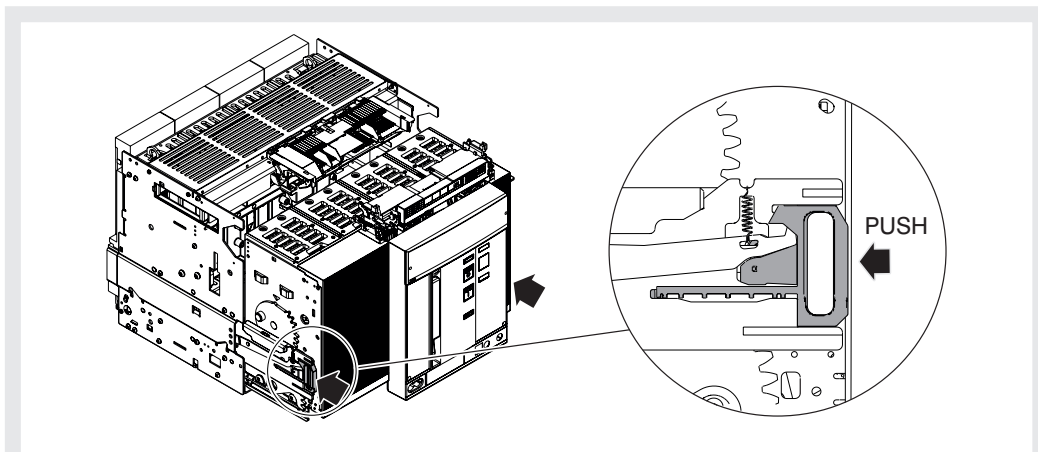

Figure 41

Continued on the next page

8. Extract the disconnection crank from its housing See Figure 42.
9. Press the lock pushbutton and insert the crank in the moving part. In this phase the moving part is still in **DISCONNECT** position. See Figure 43.

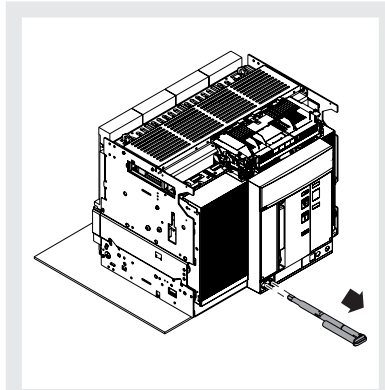

Figure 42

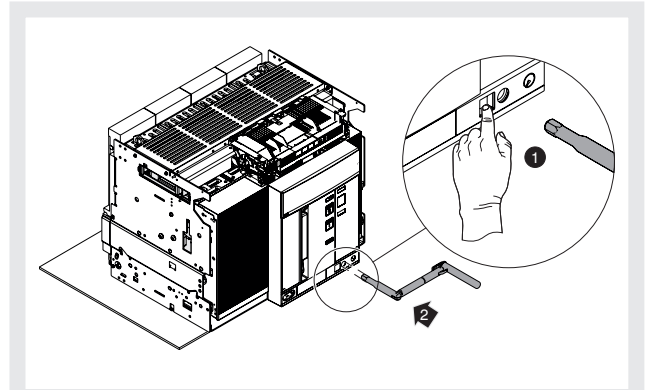

Figure 43

10. Turn the crank clockwise until the pushbutton comes out and the indicator shows that the circuit-breaker is in **TEST** position. See Figure 44.

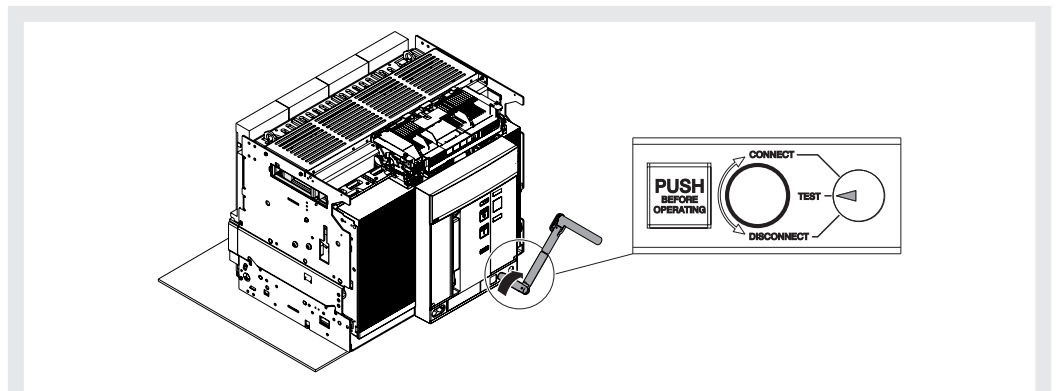

Figure 44

11. Press the lock button and rotate the crank clockwise until it comes out and the indicator shows that the circuit-breaker is in **CONNECT** position. See Figure 45.

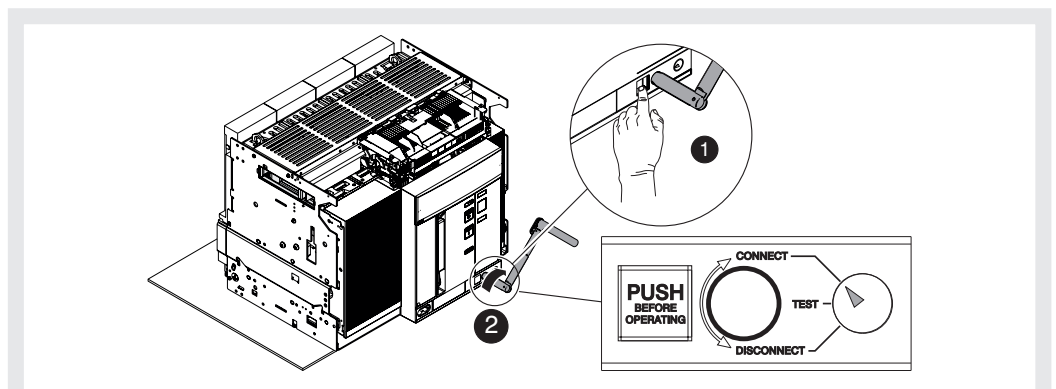

Figure 45

Continued on the next page

12. Extract the crank. See Figure 46.
13. Replace the crank in its housing See Figure 47.

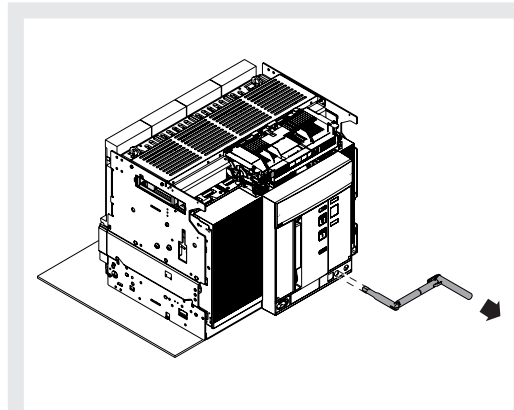

Figure 46

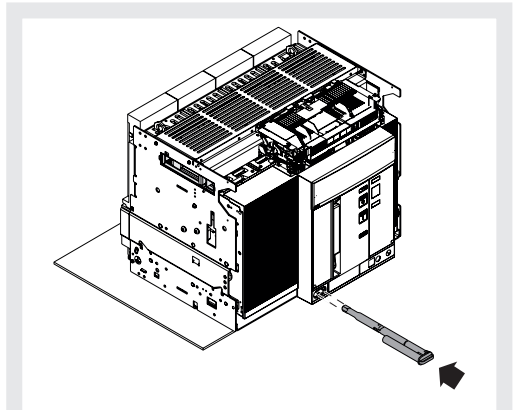

Figure 47



WARNING! The disconnecter connected must be open in order to reach the test position. The fail-safe in the UL version prevents the disconnecter from being removed from the fixed part when the springs are loaded. Release spring tension before removing disconnecter from fixed part. For further details, consult the Mechanical Safety Accessories chapter in document [1SDH001330R1002](#).

To extract the moving part from the fixed part, perform the same steps indicated for insertion in reverse order.

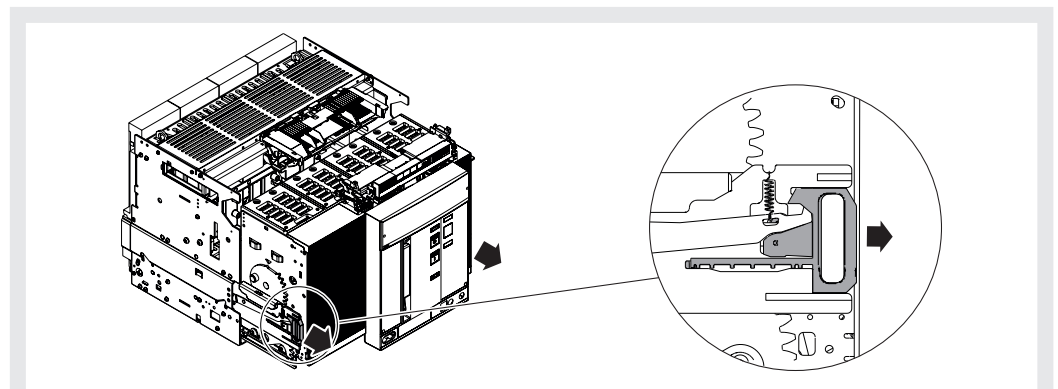

Figure 48

Continued on the next page

Always use both levers of the guides on the fixed part when racking out the circuit-breaker. See Figure 48.

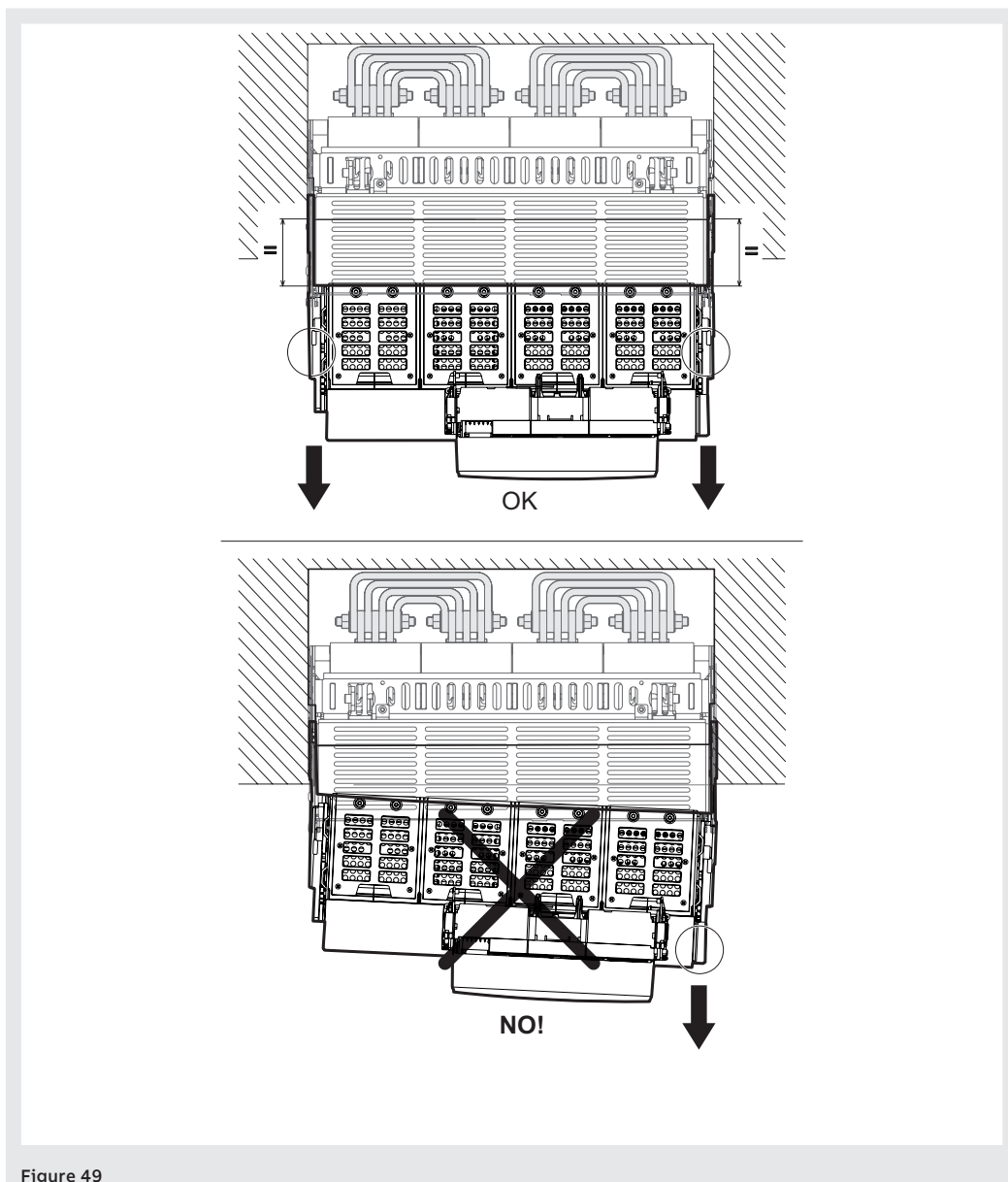

Figure 49



WARNING! When withdrawing the moving part, make sure that both guides on the fixed part travel to the same extent, thereby keeping the moving part parallel to the fixed part. See Figure 49.

Mechanical position indicators

The following are the possible positions where you can find the mobile part of a withdrawable circuit-breaker during its use:

- circuit breaker in DISCONNECT position (see Figure 50)
- circuit-breaker in test position (see Figure 51)
- circuit-breaker in CONNECT position (see Figure 52)

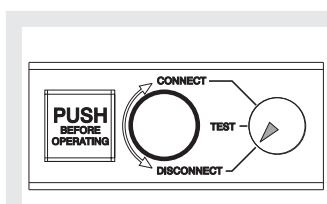

Figure 50

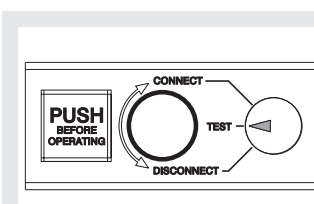

Figure 51

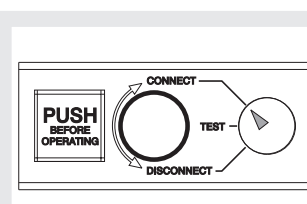

Figure 52

4 - Environmental conditions

Details related to this chapter are available in the manual [1SDH001330R1002](#) (Emax 2 engineering manual) available on the website ABB library.

5 - Installation

Warnings and precautions before the installation

The following warnings and precautions must be respected before installing the circuit-breaker in the switchgear



WARNING!

- **Disconnect the power from the circuit-breaker (power circuit and auxiliary circuits)**
- **Make sure the circuit-breaker is disconnected from all sources of energy**
- **Switch the circuit-breaker to the open position with springs discharged**



NOTE: *the qualified personnel tasked with handling and lifting work must use suitable safety equipment.*

Mounting of the fixed circuit-breaker

Fix the circuit-breaker to a horizontal surface using 4 x M10 screws. See Figure 53.

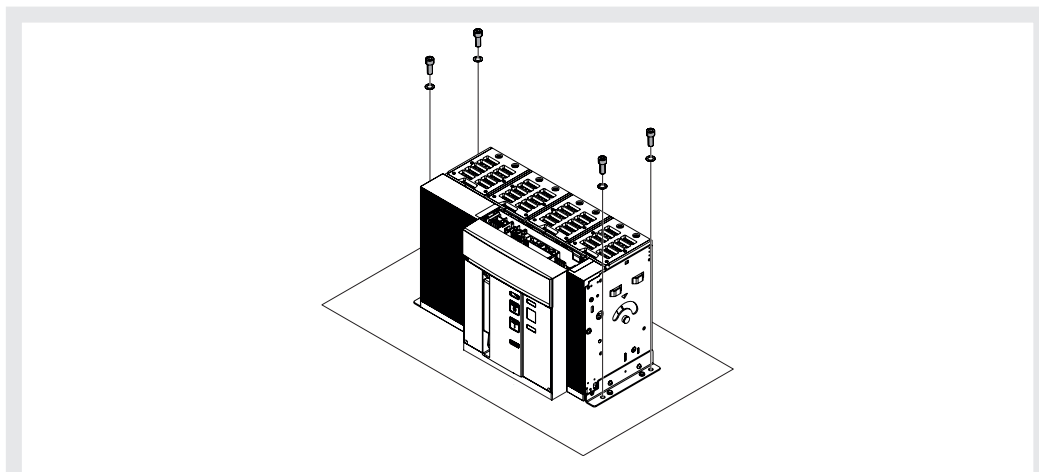

Figure 53



WARNING! Emax2 E4.2 MS/DC-E circuit-breakers can only be installed in the vertical position.

Mounting anti-insertion locks

Information on the assembly is available on the website <https://library.abb.com> in particular in the kit sheet [1SDH001000R0701](#).

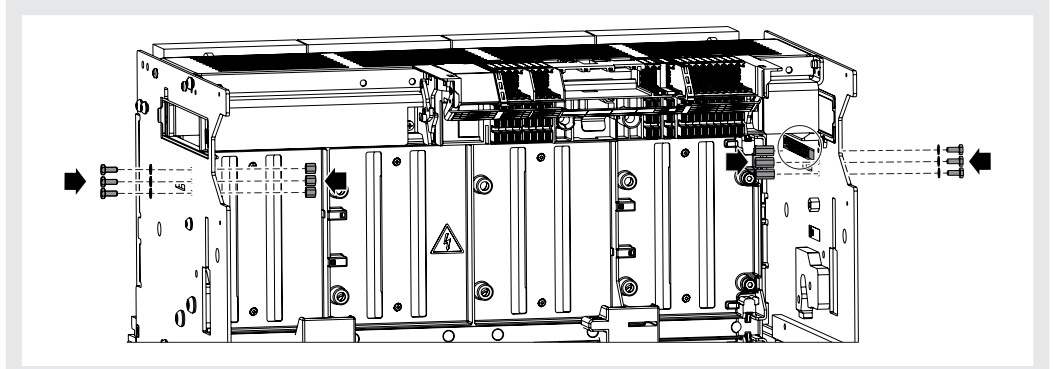

Figure 54

Mounting the fixed part of the withdrawable circuit-breaker

Fasten the fixed part to a horizontal surface using four M8 × 25 screws. The screws are supplied by ABB. See Figure 55. Tighten the screws with tightening torque = 21 N·m - 186 lb·in.

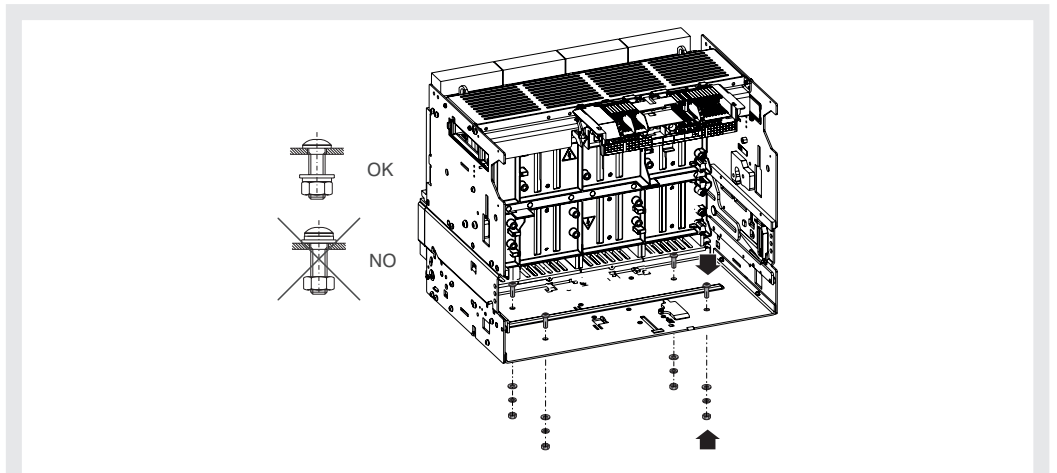

Figure 55



WARNING! Emax E4.2 circuit breakers can only be installed in vertical position

Types of terminal

The Emax 2 MS/DC-E range can be equipped with different combinations of terminals depending on the In. Their position is established by the chosen configuration.

The following are the different types of terminal:

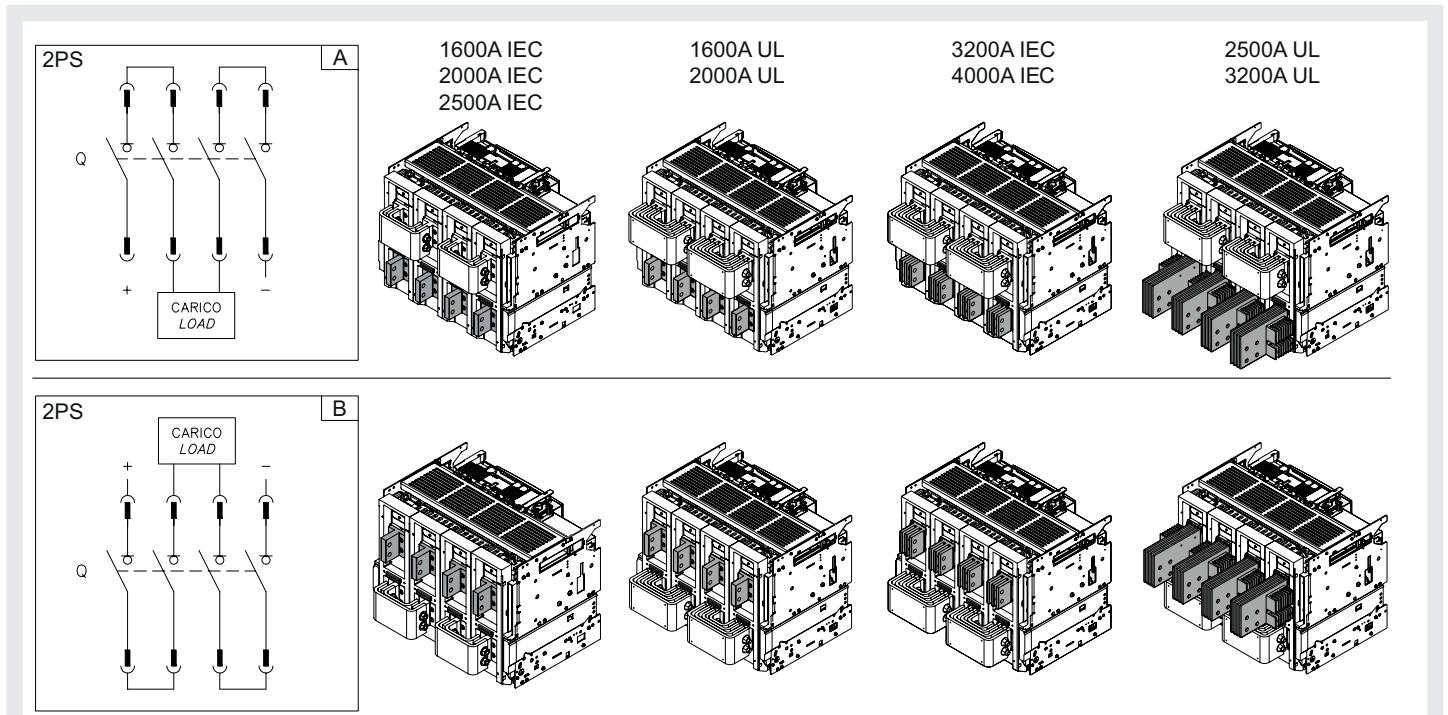

Figure 56

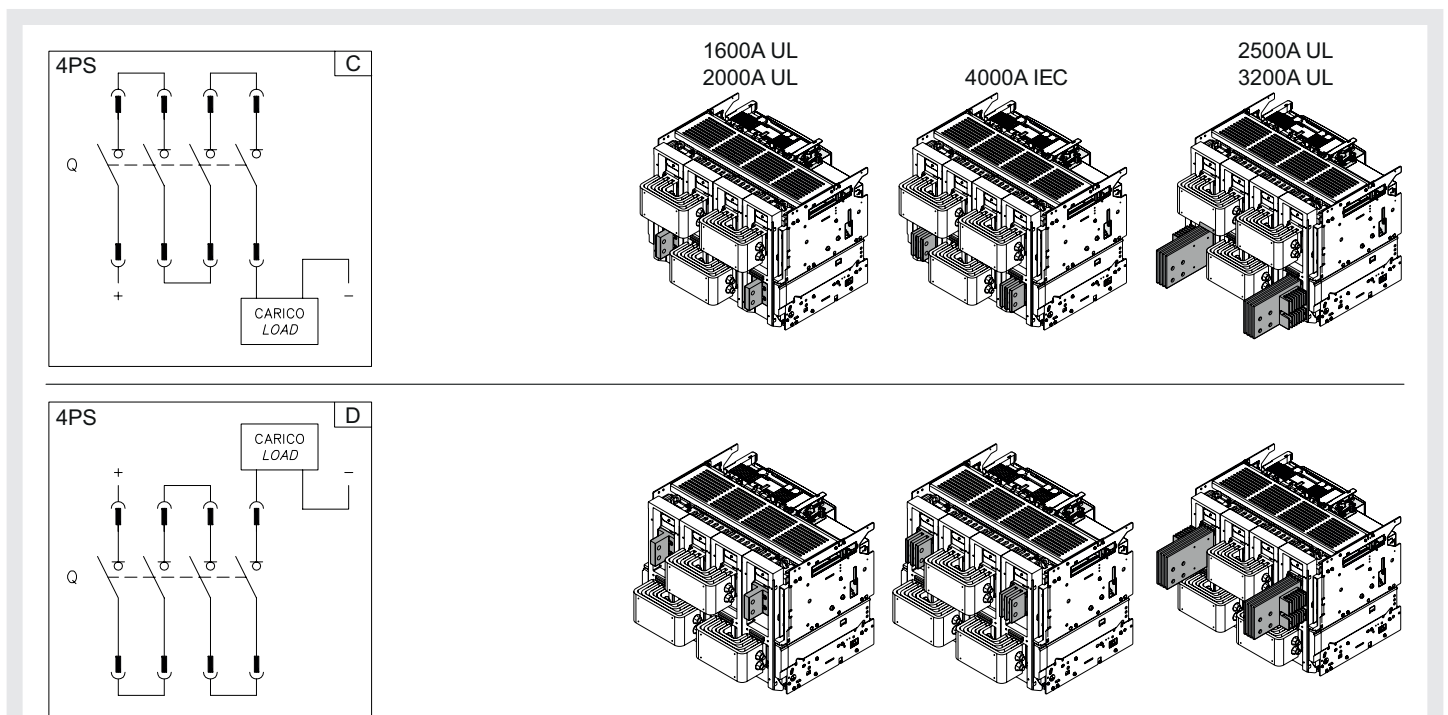

Figure 57

Change of position of the vertical/horizontal terminals

The circuit-breaker is supplied with single-tang terminals (IEC/UL Figure 58 UL and Figure 59 UL) or multi-tang (only for IEC Figure 60 IEC and Figure 61 IEC).

Changing from horizontal to vertical and vice versa can be achieved at any time with these rear terminals, with the exception of versions E4.2 UL 2500A and 3200A. Tighten the M8 screws with tightening torque = 20 N·m - 177 lb·in.

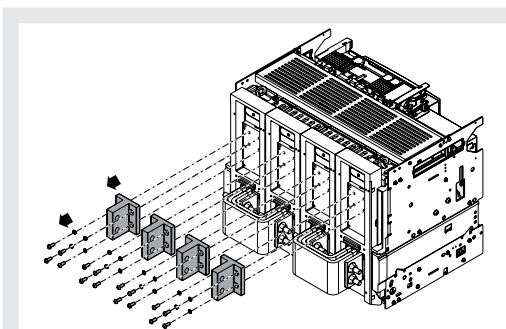

Figure 58 UL

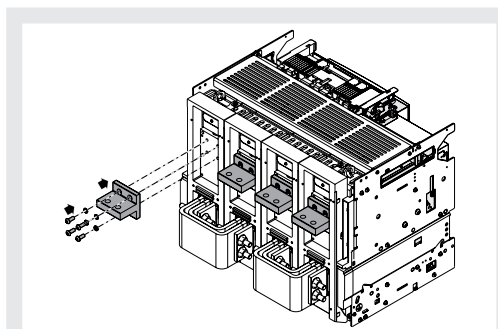

Figure 59 UL

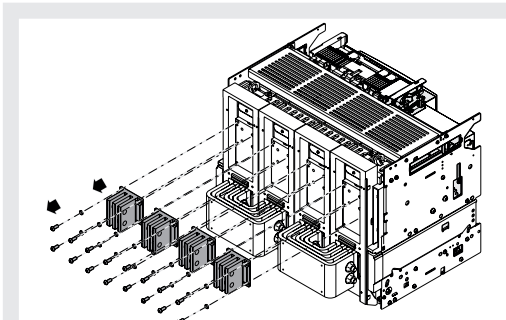

Figure 60 IEC

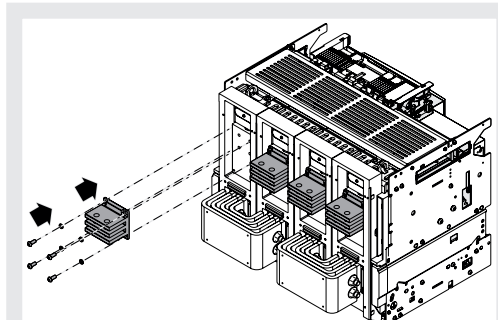

Figure 61 IEC

Clearances Information on clearances is available on the website <https://library.abb.com>
The following layout is also available [1SDH001301R0001](#) - Cubicle Emax E4.2

Phase separators and insulation frame

Phase separators are mandatory for the 2ps configuration while insulation barriers to segregate the live parts can be positioned in the 4ps configuration.

Phase separators are mandatory if, between two phases, the minimum distance between the screws that fix the circuit-breaker terminals to the connection bars is less than 14 mm - 0.55".

Fixed versions also have mandatory insulation frame and additional phase separator for top side of breaker.

Information on assembly is available on the website <https://library.abb.com> in particular with the kit sheets [1SDH001000R0746](#) and [1SDH001000R0810](#).

Connection to the power circuit

A circuit-breaker is connected to the power circuit using the connection busbars of the switchboard fixed to the circuit-breaker terminals.

Emax 2 circuit-breakers are tested in accordance with standards IEC 60947.2-3, UL 1066 and UL 489.

The switchboard designer is responsible for busbar sizing, which must be validated by application of the tests provided for by the pertinent standards.

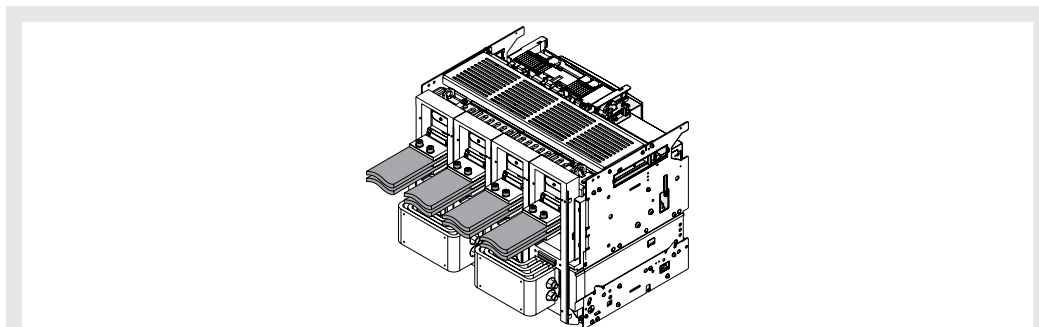

Figure 62



IMPORTANT: it is possible to obtain different capacities for the connections by altering the thickness and number of busbars in parallel.

The following tables provide some examples of the quantity and the sizes of the connections that can be used for each type of circuit-breaker:

	Iu (A)	Vertical terminals		Horizontal terminals	
		Q.ty	Dimension of busbars (mm)	Q.ty	Dimension of busbars (mm)
IEC 60947-3	4000	4	100 × 10	4	100 × 10
	3200	3	100 × 10	3	100 × 10
	2500	2	100 × 10	2	100 × 10
	2000	2	100 × 80	2	100 × 80
	1600	2	100 × 5	2	100 × 5

	Iu (A)	Vertical terminals		Horizontal terminals		
		Q.ty	Dimension of busbars (in)	Q.ty	Dimension of busbars (in)	
UL 489B	3200	5	1/4 × 3	-	-	
		4	1/4 × 4	-	-	
UL 489B UL 489F	2500	3	1/4 × 4	-	-	
		2000	4	1/4 × 2	4	1/4 × 2,5
			2	1/4 × 3	2	1/4 × 3



IMPORTANT: before proceeding with the connection between terminals and connection busbars:

- make sure that the contact surfaces of the busbars are free of burrs, dents, traces of rusting, dust or traces of grease.
- make sure, if aluminium busbars are used, that they are tin plated in the contact areas.
- make sure that the busbars do not exert forces in any direction on the terminal.
- for fastening purposes use strength class 8.8 M12 screws or threaded rods with spring washers and apply 70 Nm - 620 lb in tightening torque.



NOTE: information about circuit-breaker performance in the switchgear in the various configurations is available in the website

<https://new.abb.com/low-voltage/products/circuit-breakers/emax2>

Overall dimensions

Information on the overall dimensions is available on the website <https://library.abb.com>

The following drawings are also available in .dxf format:

[1SDH001001R0112](#) - E4.2-E F IV 2PS H-V 2500A

[1SDH001001R0113](#) - E4.2-E F IV 4PS H-V 2500A

[1SDH001001R0114](#) - E4.2-E F IV 2PS H-V 4000A

[1SDH001001R0115](#) - E4.2-E F IV 4PS H-V 4000A

[1SDH001001R0116](#) - E4.2-E W IV 2PS H-V 2500A

[1SDH001001R0117](#) - E4.2-E W IV 4PS H-V 2500A

[1SDH001001R0120](#) - E4.2-E W IV 2PS H-V 4000A

[1SDH001001R0119](#) - E4.2-E W IV 4PS H-V 4000A

[1SDH001001R0309](#) - E4.2-E F IV 2PS H-V 2000A UL

[1SDH001001R0308](#) - E4.2-E F IV 4PS H-V 2000A UL

[1SDH001001R0309](#) - E4.2-E F IV 2PS V 3200A UL

[1SDH001001R0310](#) - E4.2-E F IV 4PS V 3200A UL

[1SDH001001R0311](#) - E4.2-E W IV 2PS H-V 2000A UL

[1SDH001001R0312](#) - E4.2-E W IV 4PS H-V 2000A UL

[1SDH001001R0313](#) - E4.2-E W IV 2PS V 3200A UL

[1SDH001001R0314](#) - E4.2-E W IV 4PS V 3200A UL

Positioning anchor plates

The diagram below indicates the distance for positioning the first anchor plate according to the circuit-breaker type and the peak current:

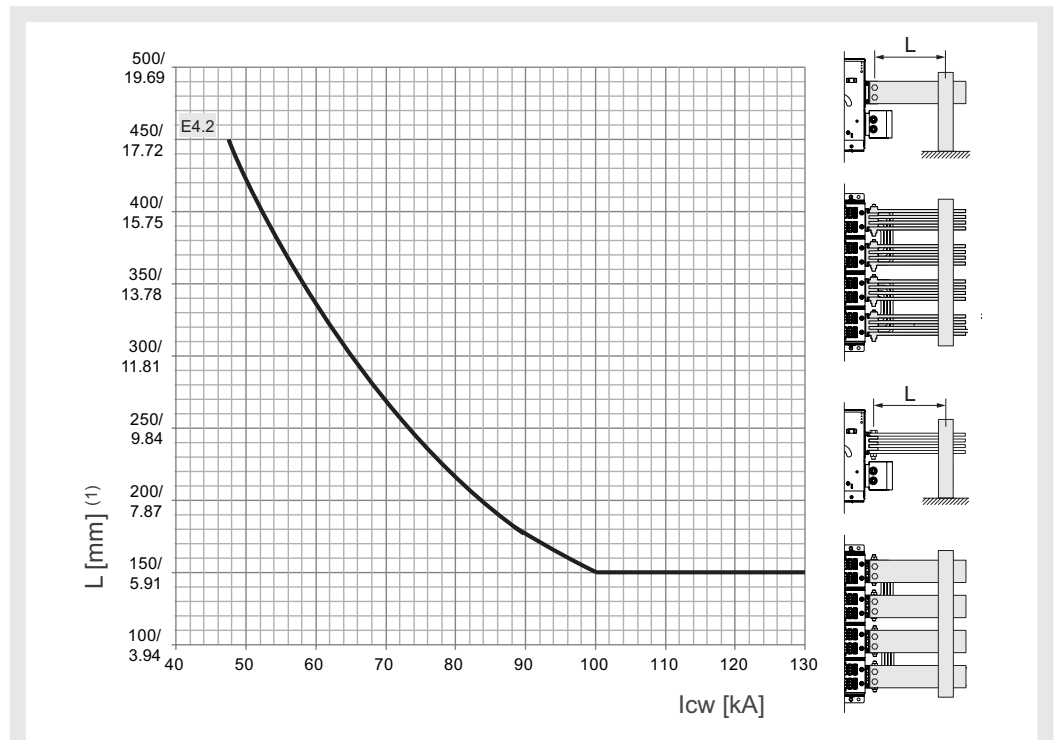

Figure 63

(1): distance of the first anchor plate from the circuit-breaker terminals

Positioning anchor plates E4.2-A 3200 A

The anchor plates must be positioned as indicated in the figure.

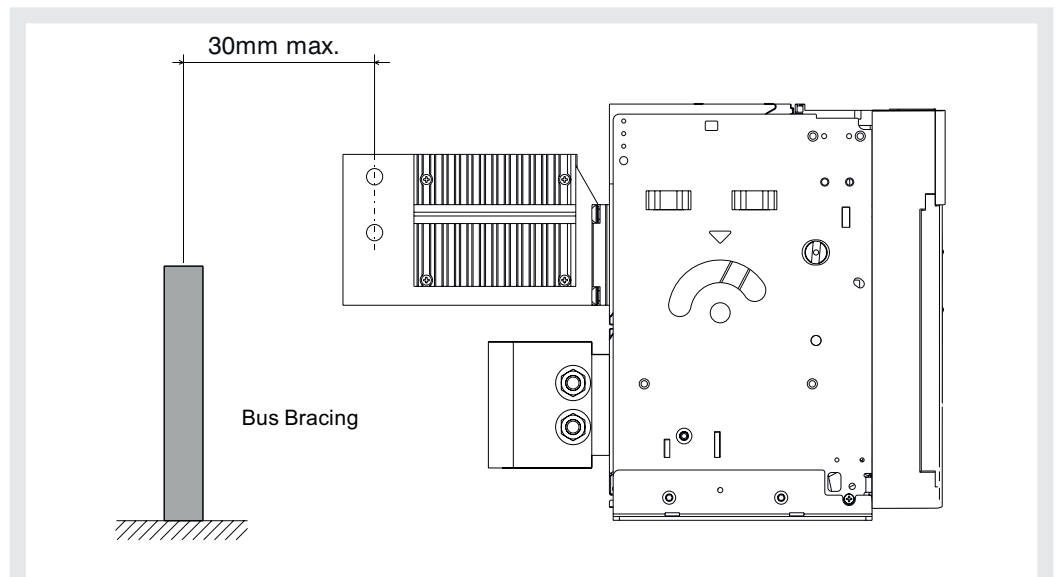

Figure 64

Grounding The circuit-breakers in fixed version and the fixed part of withdrawable circuit-breakers are equipped with a screw for the ground connection.

The connection must be implemented by means of a conductor of suitable cross-section according to the IEC 61439-1 Standard.

Clean and degrease the area around the screw before making the connection.

After assembly of the conductor, tighten the screw with a torque of 2 N·m - 17.7 lb·in.

Alternatively, no connection will be required if circuit-breaker frame continuity with the switchgear earthing is provided by the metal contact (support) between the circuit-breaker and the metal structure of the switchgear (or a part of the protection circuit) (as long as there are no insulating panels between the circuit-breaker and the metal frame of the switchgear).

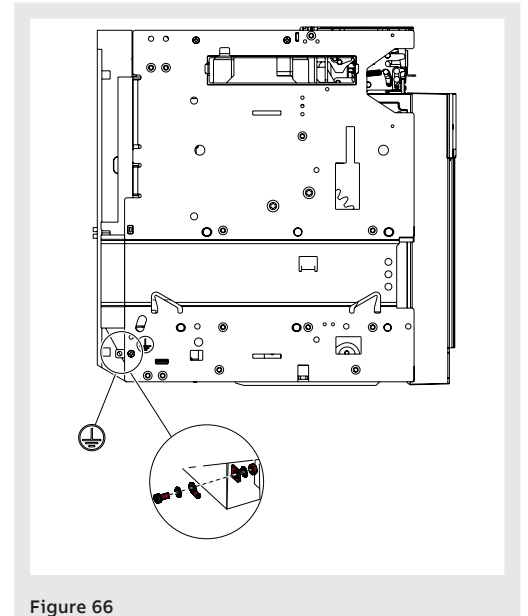
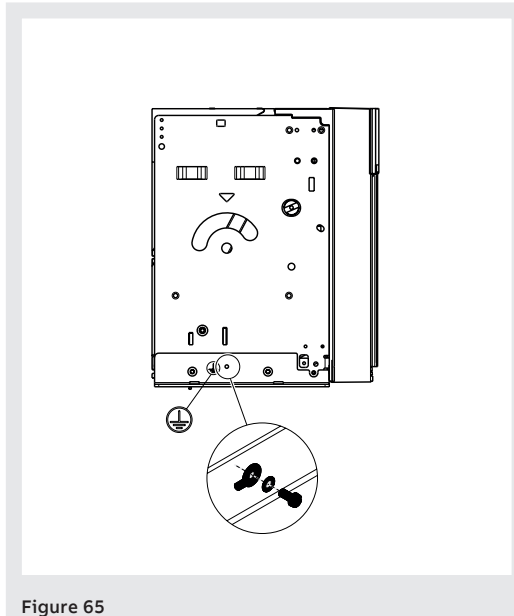

Accessories

1 - Overview

Overview and connection Emax 2 circuit-breakers have a set of electronic, electrical and mechanical accessories, the availability of which depends on the CB model.
Consult manual 1SDH001330R1002 for details, circuit diagrams 1SDM000017A1001 and assembly instructions for the connection.

2 - Wiring diagrams

General wiring diagrams Switch-disconnector for insulated network.

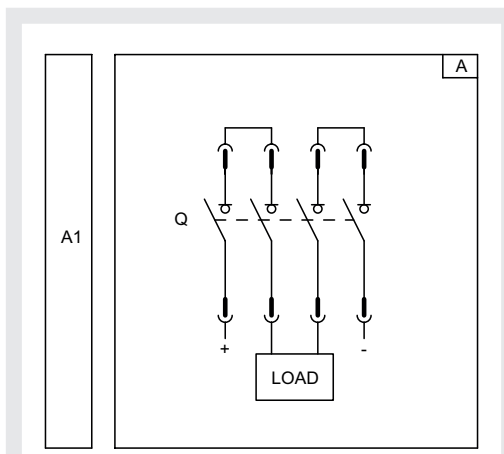

Diagram A - Cable entrance from below

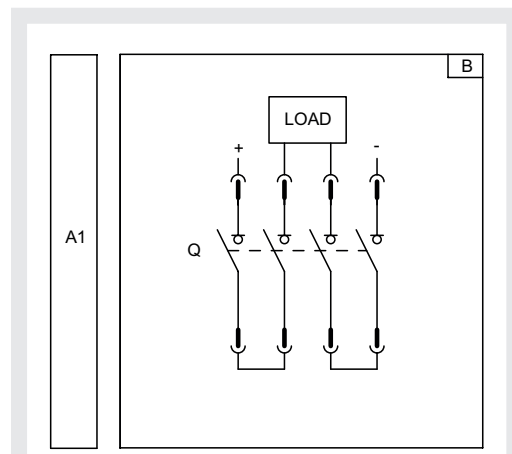

Diagram B - Cable entrance from above

Switch-disconnector for networks with negative polarity connected to earth.

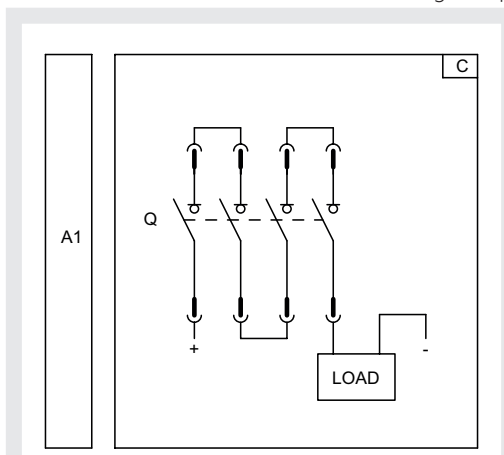

Diagram C - Cable entrance from below

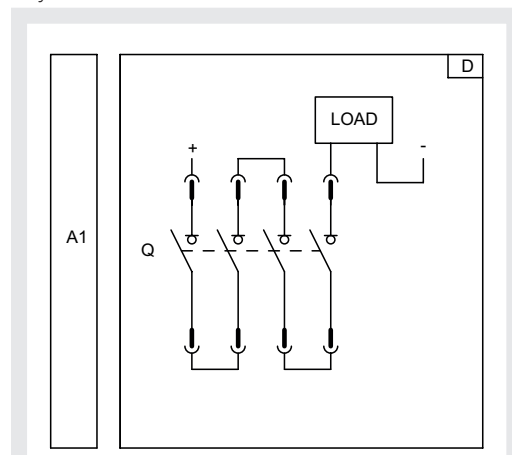

Diagram D - Cable entrance from above



NOTE: Supply terminals and load terminals are interchangeable

Continued on the next page

The following is a key to the symbols used in the wiring diagrams:

Symbol	Description
*	See the note indicated by the letter
A1	Applications on movable part of switch-disconnector
A3	Applications on fixed part of switch-disconnector
A4	Indicative operating and signaling devices and connections outside switch-disconnector
D	Electronic time delay device of undervoltage coil YU, outside switch-disconnector
M	Motor for loading closing springs
Q	Switch-disconnector
Q / 1...Q / 25	Open/close auxiliary contacts of switch-disconnector
RTC	Contact for signaling switch-disconnector ready to close
S33M / 1...2	Limit contacts of spring loading motor
SC	Pushbutton or contact for closing of switch-disconnector
SO	Pushbutton or contact for immediate opening of switch-disconnector
SO1	Pushbutton or contact for opening switch-disconnector with delayed trip
X	Delivery connector for auxiliary circuits of withdrawable switch-disconnector
XB1...XB6	Connectors for circuit-breaker applications
XV	Delivery terminal box for auxiliary circuits of fixed switch-disconnector
YC	Closing coil
YC2	Second closing coil
YO	Opening coil
YO2	Second opening coil
YU	Undervoltage coil

The following is a key to the notes used in the wiring diagrams:

Note	Description
A)	When there are mixed auxiliary contacts, Q1 and Q2 are 400 V, while Q3 and Q4 are 24 V. Then Q5, Q6, Q7 are 400 V, while Q8, Q9, Q10 are 24 V.
B)	Always supplied with motor for loading the closing springs in Fig.13.

Continued on the next page

Electrical and mechanical accessories

Electrical and mechanical accessories:

Type of accessory	Accessory	Switch-disconnectors
Electrical signalling	AUX 4Q	R
	AUX 6Q	R
	AUX 15Q ⁽⁵⁾	R
	Ekip AUP ⁽¹⁾	R
	Ekip RTC	R
	S51	-
	S51/2	-
	S33 M/2	R
Electrical control	YO ⁽⁴⁾ - YC	R
	YO2 ⁽⁴⁾ - YC2	R
	YU ⁽²⁾⁽⁴⁾	R
	YU2 ⁽²⁾⁽⁴⁾	R
	M	R
	YR	-
Security mechanical	KLC - PLC	R
	KLP - PLP ⁽¹⁾	R
	SL ⁽¹⁾	S
	DLR ⁽¹⁾	R
	DLP ⁽¹⁾	R
	DLC ⁽⁵⁾	R
	Anti-insertion lock	S
	MOC	R
	FAIL SAFE ⁽³⁾	R
Protection mechanical	PBC	R
	IP54	R
	Insulating protections ⁽⁶⁾	S
Interlocks	MI ⁽⁵⁾	R
Lifting plates	-	R

S: Standard. R: on request.

⁽¹⁾ For withdrawable version only.

⁽²⁾ Incompatible with FAIL SAFE. Can be ordered for UL on request.

⁽³⁾ Incompatible with YU; standard for UL version.

⁽⁴⁾ A maximum of two accessories are available for YO and YU.

⁽⁵⁾ Not available for withdrawable circuit-breakers with lateral fastening.

⁽⁶⁾ Only for fixed version

Putting into service and maintenance

1 - Putting into service

- Introduction** The general check is necessary:
- when the circuit-breaker is put into service for the first time
 - after prolonged inactivity of the circuit-breaker



HAZARD! RISK OF ELECTRIC SHOCK! Test the circuit-breaker with all switchgear apparatus de-energized.



IMPORTANT: The verifications involve procedures which must only be performed by persons skilled in the electrical field (IEV 195-04-01): person with sufficient training and experience to enable him or her to perceive risks and avoid the dangers potentially created by electricity).



- General checks** Before putting it into service for the first time or after a prolonged period of inactivity, some checks must be carried out on the circuit-breaker and the environment in which it is installed:

Points to be checked	Checks
Switchgear	1. Sufficient change of air to avoid overtemperatures
	2. Clean location, free of all installation refuse (e.g.: cables, tools, metal splinters)
	3. Circuit-breaker mounted correctly (tightening torques, clearances respected)
	4. The installation environmental conditions must be consistent with the "Environmental conditions" specifications on page 25
Connections	1. Power connections tightened to the terminals of the circuit-breaker
	2. Busbars with adequate cross-section
	3. Correct ground connections
	4. Maximum distances of separators respected
Operations	Perform some opening and closing operations (See chapter "Description of the product - circuit-breaker opening/closing operations on page 18). The spring loading lever must move with regularly
	WARNING! in the presence of an undervoltage coil the circuit-breaker can be closed only after the trip unit is energized



NOTE: for security reasons, ABB strongly advises you to change the PIN right from the first access and to keep it with care.

Check accessories The following procedures for checking the accessories are to be performed before they are put into service:

Accessories ^(*) to be checked	Procedure
Gearmotor	1. Power the gearmotor to charge the springs at the relevant rated voltage.
	Result: The springs are charged correctly. The signals are normal. When the springs are charged the gearmotor stops.
	2. Perform some closing and opening operations.
	Result: The gearmotor recharges the springs after every closing operation.
	 NOTE: <i>If present, power the undervoltage coil in advance.</i>
Undervoltage coil	1. Power the undervoltage coil at the relevant rated voltage and perform the closing operation on the circuit-breaker.
	Result: The circuit-breaker closes correctly; the signals are normal.
	2. Turn off the voltage supply to the trip unit. The circuit-breaker opens.
	3. Power the undervoltage coil at the relevant rated voltage and perform the closing operation on the circuit-breaker.
	Result: The circuit-breaker closes; the signal switches over.
	 WARNING! If the undervoltage coil has been tripped by a power failure, the circuit-breaker can be closed only after the coil has been energized electrically. Make sure that the coil has effectively been tripped due to a power failure. Otherwise, examine the circuit-breaker and the associated equipment to make sure that they are in a good condition.
Opening coil	1. Close the circuit-breaker.
	2. Power the opening coil at the relevant rated voltage.
	Result: The circuit-breaker opens correctly; the signals are normal.
Closing coil	1. Open the circuit-breaker.
	2. Charge the springs manually or electrically.
	3. Power the closing coil at its rated voltage.
	Result: The circuit-breaker closes correctly; the signals are normal.

^(*) *If present.*

^(**) *Withdrawable versions only.*

Continued on the next page

Accessories (*) to be checked	Procedure
Lock for circuit-breaker in open position (key or padlock)	1. Open the circuit-breaker 2. Keep the opening pushbutton pressed 3. Turn the key and remove it 4. Attempt the circuit-breaker closing operation. Result: Both manual and electrical closing is prevented.
Auxiliary open/ closed contacts of the circuit-breaker	1. Connect the auxiliary contacts to appropriate signalling circuits or to the multimeter. 2. perform some closing and opening operations on the circuit-breaker. Result: signalling occurs normally.
Circuit-breaker connected, isolated for test, disconnected auxiliary contacts	1. Connect the auxiliary contacts to appropriate signalling circuits. 2. bring the circuit-breaker to the connected, isolated for test and disconnected position. Result: the signals due to the relative operations are normal.
Locking devices for connected/ test/disconnected positions (**)	1. Perform operating tests. Result: the interlocks function correctly.
Interlocks between circuit breakers assembled side by side and stacked	1. Perform operating tests. Result: the interlocks function correctly.
Racking-in/out device (**)	1. Perform a few racking-in and racking-out operations. Result: in the rack-in operation the circuit-breaker is connected correctly. There is no particular resistance during the first turns of the handle.
Auxiliary accessories and auxiliary voltage	Verify the proper installation. The supply voltage of the auxiliary accessories must be between 85% and 110% of the rated voltage for the auxiliary accessories.

(*) If present.

(**) Withdrawable versions only.

Final check list Perform the operations described below after having completed the general inspection procedures and checked the accessories. Print this sheet and use it to make an inspection report in the "Checks" column.

Operation		Description	Check
1	Circuit-breaker OFF	Open the circuit-breaker	
2	Circuit-breaker connected	Switch the circuit-breaker in withdrawable version to the connected position and reposition the crank in its seat	
3	Connecting the voltage	Connect the auxiliary voltage	
4	Closing the switchgear	Close the switchgear door	
5	Charging the springs	Charge the closing springs	
6	Undervoltage coil	Make sure that undervoltage coil is energized	
7	Opening and closing coils	Make sure that opening and closing coils are NOT energized	
8	Mechanical interlock of the circuit-breaker	If present, make sure that the mechanical interlock of the circuit-breaker is not active	
9	Locking devices	If present, make sure that the locking devices of the circuit-breaker are not active	
10	Status signals	Make sure that the signalling devices on the front of the circuit-breaker indicate: circuit-breaker open - springs discharged O - OPEN and white spring signalling device DISCHARGED SPRING	

2 - Identification of alarms or failures

Faults, causes and remedies

The following is a list of possible fault situations, their possible causes and suggestions for resolving them.

Faults	Possible causes	Suggestions
The circuit-breaker doesn't close when the closing pushbutton is pressed	The open-position key lock or padlock is activated	Unlock the lock in open position using the relevant key
	The circuit-breaker is in an intermediate position between connected and isolated for test or between isolated for test and disconnected	Complete the rack-in operation
	The undervoltage coil is not energized	Check the power supply circuit and the power supply voltage
	The opening coil is permanently energized	Correct operating condition.
	The trip unit pushbutton is pressed (withdrawable version)	Rotate the crank to complete
The circuit-breaker doesn't close when the closing coil is powered	The power supply voltage of the auxiliary circuits is too low	Measure the voltage: it should not be lower than 70% of the rated voltage of the coil
	The power supply voltage is different from that indicated on the rating plate	Check the voltage on the rating plate
	The cables of the coil are not inserted correctly in the terminals	Make sure there is continuity between cable and terminal and if necessary reconnect the cables of the coil to the terminals
	The connections in the power supply circuit are wrong	Check the connections using the relevant wiring diagram
	The closing coil is damaged	Replace the coil
	The operating mechanism is blocked	Perform the closing operation manually; if the fault persists contact ABB
	The open position key lock is activated	Unlock the lock in open position using the relevant key
	The circuit-breaker is in an intermediate position between connected and test or the trip unit pushbutton is pressed (withdrawable version)	Complete the rack-in operation
	The undervoltage coil is not energized	Make sure that undervoltage coil is energized properly
	The opening coil is permanently energized	Correct operating condition. If necessary, disconnect the power from the opening coil
The racking out crank handle is inserted (withdrawable version)	Remove the crank	
The circuit-breaker doesn't open when the opening pushbutton is pressed	The operating mechanism is blocked	Contact ABB

Continued on the next page

Faults	Possible causes	Suggestions
The circuit-breaker doesn't open when the opening coil is powered	The operating mechanism is blocked	Contact ABB
	The power supply voltage of the auxiliary circuits is too low	Measure the voltage: it should not be lower than 85 % of the rated voltage of the coil
	The power supply voltage is different from that indicated on the rating plate	Use the correct voltage
	The cables of the coil are not inserted correctly in the terminals	Make sure there is continuity between cable and terminal and if necessary reconnect the cables of the coil to the terminals
	The connections of the power supply circuit are wrong	Check the connections using the relevant wiring diagram
	The opening coil is damaged	Replace the coil
The circuit-breaker doesn't open despite the command of the undervoltage coil	The operating mechanism is blocked	Perform the opening operation manually; if the fault persists contact ABB
It is not possible to charge the closing springs by means of the manual charging lever	The operating mechanism is blocked	Contact ABB
It is not possible to charge the closing springs by means of the gearmotor	The cables of the gearmotor are not inserted correctly in the terminals	Make sure there is continuity between cable and terminal and if necessary reconnect the cables of the gearmotor to the terminals
	The connections of the power supply circuit are wrong	Check the connections using the relevant wiring diagram
	The circuit-breaker is in disconnected position	Switch the circuit-breaker to the test or connected position
	The gearmotor protection internal fuse has tripped	Replace the fuse
	The gearmotor is damaged	Replace the gearmotor
It is not possible to press the button in order to insert the racking out crank handle	The circuit-breaker is closed	Press the opening pushbutton in order to allow the insertion of the crank with the circuit-breaker open
It is not possible to insert the moving part in the fixed part	The racking-in/racking-out operation is not performed correctly	See chapters "Circuit breaker racking-in/racking-out operations" on pages 20 See the document 1SDH002013A1001
	The moving part is incompatible with the fixed part	Check the compatibility between the moving part and the fixed part
It is not possible to lock the circuit-breaker in the open position	The opening pushbutton is not pressed	Press the opening pushbutton and activate the lock
	The lock in open position is defective	Contact ABB

Continued on the next page

3 - Maintenance

Safety standards Comply with the following mandatory recommendations during maintenance work.



HAZARD! RISK OF ELECTRIC SHOCK! Risk of electric shock or accident.



WARNING! before proceeding with any maintenance operation, it is mandatory to:

- Set the circuit-breaker to the open position and make sure that the springs of the operating mechanism are discharged.
- In the case of a withdrawable circuit-breaker, extract the circuit-breaker from the fixed part (see the indication DISCONNECTED)
- If work must be performed on fixed circuit-breakers or on fixed parts, disconnect the power supply to the power circuit and auxiliary circuits and visibly ground the terminals on both the supply side and load side.
- Use adequate personal protection equipment, ensure that the apparatus is in a safe condition and proceed in accordance with the Laws in force.

Skilled personnel The maintenance operations must be carried out by Skilled Personnel: skilled person, in the electrical field (IEV 195-04-01): person with sufficient training and experience to enable him or her to perceive risks and avoid the dangers potentially created by electricity). ABB declines all liability for damage to persons or property caused by failure to comply with the instructions in this document.

Circuit-breaker life The circuit-breakers SACE Emax 2, with or without opening or closing coils, can withstand the following operating cycles if regularly serviced. For further information see chapter 4 - Environmental conditions on page 25.

IEC 60947-3	Mechanical Operations		Electrical Operations (tau = 2 ms)	
	No. x 1000	Frequency/Hour	No. x 1000	Frequency/Hour
1600	15	20	0,5	20
2000	15	20	0,5	20
2500	15	20	0,5	20
3200	15	10	0,5	10
4000	15	10	0,85	10

UL 489B UL 489F	Mechanical Operations		Electrical Operations (tau = 3 ms)	
	No. x 1000	Frequency/Hour	No. x 1000	Frequency/Hour
1600	15	20	10	60
2000	15	20	8	60
2500	15	20	7	60
3200	15	10	3	60 (*)

^(*) See note of table 7.1.5.1 UL 489

Maintenance schedule Proper maintenance of the equipment allows good electromechanical operation to be maintained over time.

The maintenance plan for SACE Emax 2 circuit-breakers specifies two periodic levels of maintenance for the different types of site conditions.

The following is a table of maintenance frequency with the periodic intervals and the routine maintenance operations.

Activity	Frequency in standard environments	Frequency in dusty environments (dust level measured > 1mg/m ³)
First level maintenance (see the paragraph 4)	One year or 20% of mechanical life or 20% of electrical life	6 months or 10% of mechanical life or 10% of electrical life
Second level maintenance (see the paragraph 5)	Three years or 50% of mechanical life or 50% of electrical life or after a trip due to short-circuit	18 months or 25% of mechanical life or 25% of electrical life or after a trip due to short-circuit
Lubrication of jaw-type isolating contacts of withdrawable circuit-breaker (see the paragraph 6)	100 racking-in and racking-out operations ⁽²⁾ or three years	50 racking-in and racking-out operations ⁽²⁾ or 18 months

Compliance with the following rules is also recommended:

- even circuit-breakers that operate infrequently or that remain closed or open for long periods of time must be subjected to programmed maintenance
- All the circuit-breakers provide information on the number of operations performed in the presence of auxiliary power supply of the Trip Unit.
- During the service, visually inspect the circuit-breaker from the outside to check for the presence of dust, dirt or damage.

4 - First level maintenance

First level maintenance should be carried out in accordance with the maintenance schedule shown on page 44.

Preliminary operations



WARNING! before proceeding with any maintenance operation, it is mandatory to:

- **Set the circuit-breaker to the open position and make sure that the springs of the operating mechanism are discharged.**
- **In the case of a withdrawable circuit-breaker, extract the circuit-breaker from the fixed part (see the indication DISCONNECTED)**
- **If work must be performed on fixed circuit-breakers or on fixed parts, disconnect the power supply to the power circuit and auxiliary circuits and visibly ground the terminals on both the supply side and load side.**

Inspections and general cleaning

Perform the following checks:

1. Make sure that the circuit-breaker is clean. Remove dust and oily substances or excess grease with a clean, dry cloth and mild detergent if necessary. If there is a thick build-up of dirt, use a thinner from the greasing kit or ask for assistance from the service staff.
2. Check that the rating plates with the technical specifications of the apparatus are present.
3. Clean the rating plates with clean, dry rags.
4. Make sure that there are no foreign bodies in the circuit-breaker compartment.

Circuit-breaker connections and connections between circuit-breaker and switchboard

Perform the following checks on the connections:

1. With dry paint-brushes and rags remove dust or soil, if present (use a non- aggressive detergent if necessary. Use a cleaning product such as Chemma 18 or equivalent if there is a heavy coating of dirt).
2. Make sure there are no traces of overheating on the terminals. Overheating is detected by a different coloration of the parts in contact; the contact parts are usually silvery white in colour.
3. Check the tightness of fastening bolts for all connections to the terminals



WARNING! if work must be performed on fixed circuit-breakers or on fixed parts, disconnect the power supply to the power circuit and auxiliary circuits and visibly earth the terminals on both the supply side and load side.

Disassembly operations To disassemble the parts of the circuit-breaker:

1. Remove the transparent flange (A) of the trip unit, by turning the screws (B).
2. Remove the front cover of the circuit-breaker (C), by removing the mounting screws (D).

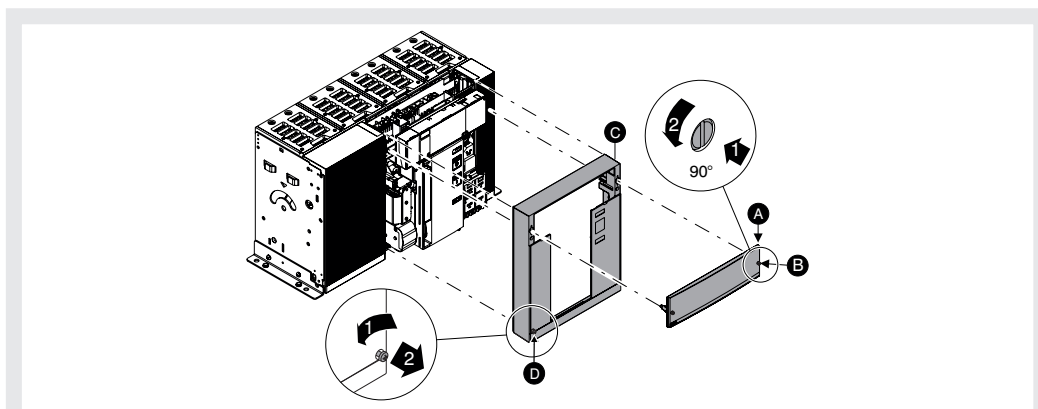

Figure 67 - Disassembly of flange and escutcheon plate

3. Remove the gearmotor (E) by removing the screw (F) and the connector.

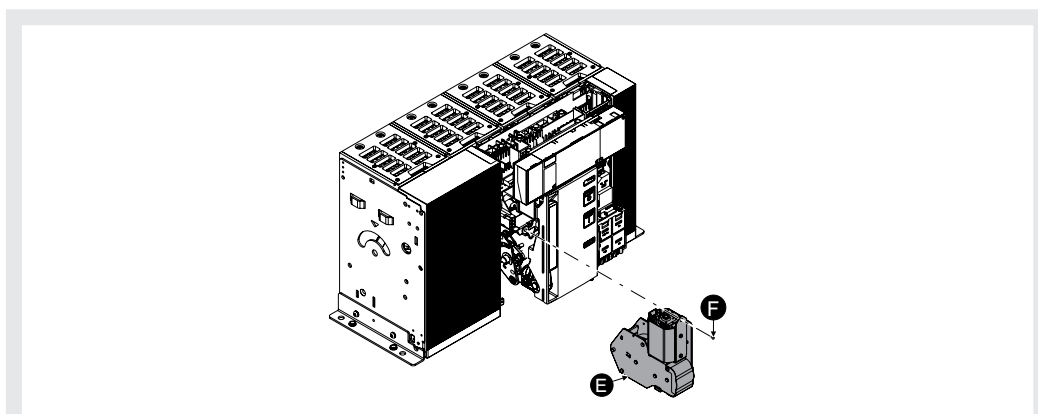

Figure 68 - Removing the gearmotor

4. If there is an undervoltage coil (G), remove it, and discharge the springs of the operating mechanism for closing and opening the circuit breaker.

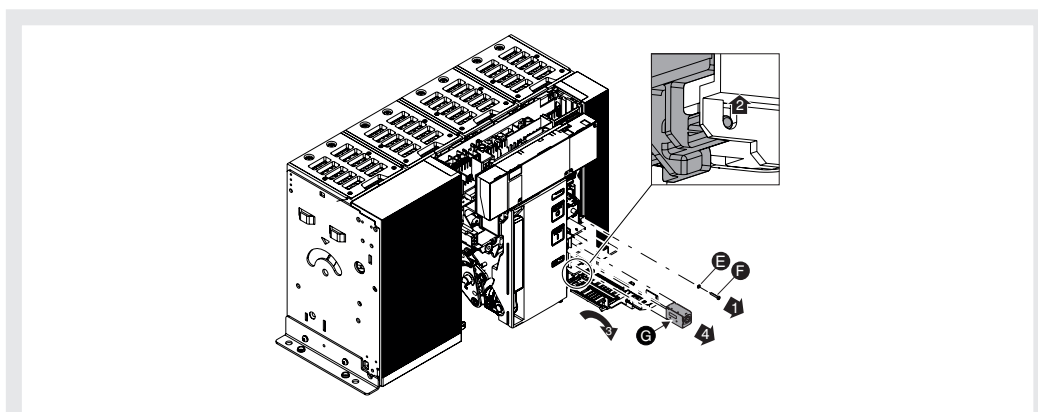

Figure 69 - Removing the undervoltage coil

Cleaning and lubrication of the operating mechanism

To clean and lubricate:

1. Clean the closing shaft and closing hook at the point indicated. In the case of excessive deposits you can use a laminate thinner such as Chemma 18 or equivalent.
2. Lubricate the closing shaft and closing latch in the indicated points, using the ABB greasing kit or Mobilgrease 28.
3. Make sure that the closing shaft is free to rotate.

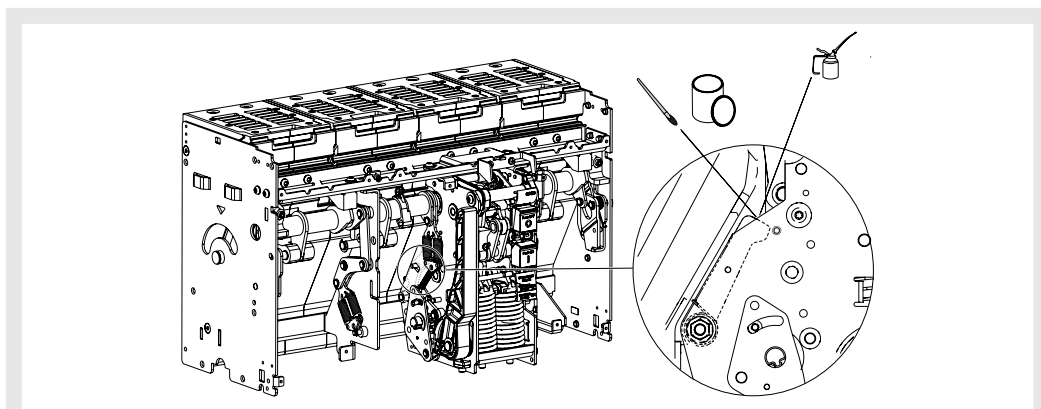

Figure 70 - Lubrication of closing latch and shaft

Inspection of electrical and mechanical accessories

Check the accessories:

1. Check that the accessories are securely fixed to the circuit-breaker.
2. Check that the accessories are connected correctly to the circuit-breaker.
3. Make sure that the coils (YU-YO-YC), if present, are in good condition (no excessive wear and tear, overheating, rupture).
4. Make sure that the mechanical operation counter functions correctly (if present) by operating the circuit-breaker.
5. Check the wear on the brushes of the gearmotor and if necessary replace them.



NOTE: it is advisable to replace the gear motor if it has performed more than 10000 spring charging operations or reached 50% of the declared mechanical life of the circuit-breaker.

Final checks Reassemble and check the circuit-breaker:

1. Reassemble all the parts by performing all the operations indicated in the paragraph “Disassembly Operations” in reverse order. If necessary, reconnect the auxiliary power supply.
2. Put the movable part (breakers) in the test position (see indication TEST).
3. Perform the following operations 10 times:
 - Opening (in both local and remote modes, if applicable)
 - Closing (in both local and remote modes, if applicable)
4. Perform the operations in the following sequence:
 - Open - Springs discharged
 - Open - Springs charged
 - Closed - Springs discharged
 - Closed - Springs charged
5. Check that the following operate correctly:
 - accessories, if provided.
 - gearmotor, if provided.
 - undervoltage coil, if provided.
 - opening coil, if provided.
 - closing coil, if provided.
 - auxiliary contacts of the circuit-breaker, if provided.
 - lock for circuit-breaker in open position (key or padlock), if provided

Interlock check Check that the vertical or horizontal interlocking devices (if provided) are installed and that they operate correctly.

⚠ WARNING! the interlocks cannot be tested in the Test or Disconnected positions.

Perform maintenance periodically as indicated in the table below.

Activity	Frequency	Maintenance operations
Functionality	1 year or	See kit sheet
Check tightness	20% of mechanical life or	
Lubrication ^(*)	20% of electrical life	As shown in the figure
Cables	Three years or 50% of the mechanical life or 50% of the electrical life of the largest circuit-breaker involved in the interlock. After a trip due to a short-circuit.	Replacement is advisable

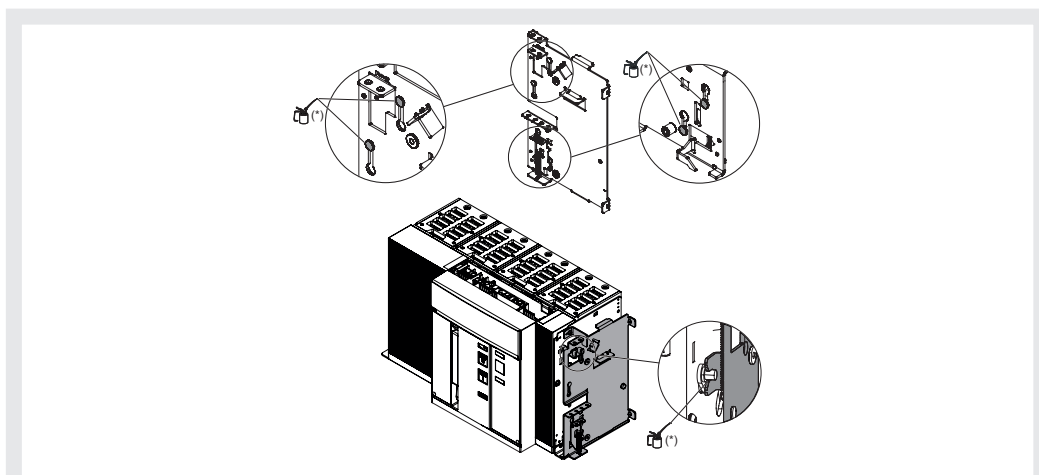

Figure 71

^(*) Use ABB greasing kit or grease of the Mobilgrease 28 type.

5 - Second level maintenance

The second level maintenance must be performed in accordance with the maintenance schedule shown on page 44.

Preliminary operations



WARNING! before proceeding with any maintenance operation, it is mandatory to:

- Set the circuit-breaker to the open position and make sure that the springs of the operating mechanism are discharged.
- In the case of a withdrawable circuit-breaker work with it withdrawn from the fixed part. For removal of the mobile part see paragraph Circuit breaker racking-in/racking-out operations on page 20.

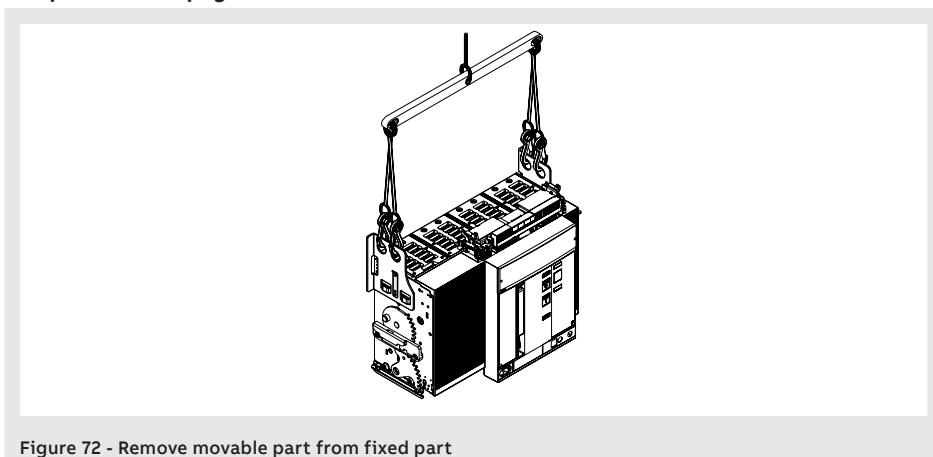

Figure 72 - Remove movable part from fixed part

- If work must be performed on fixed circuit-breakers or on fixed parts, disconnect the power supply to the power circuit and auxiliary circuits and visibly ground the terminals on both the supply side and load side.

Inspections and general cleaning

Perform the following checks:

1. Make sure that the circuit-breaker is clean. Remove dust and oily substances or excess grease with a clean, dry cloth (use a mild detergent if necessary. If there is a thick build-up of dirt, use a thinner from the greasing kit or ask for assistance from the service staff).
2. Check that the rating plates with the technical specifications of the apparatus are present.
3. Clean the rating plates with clean, dry rags.
4. If the circuit-breaker is in the withdrawable version, remove all traces of dust, mould, condensation and oxidation inside the fixed part.
5. Make sure that there are no traces of overheating or cracks, which could impair the insulating parts of the circuit-breaker
6. Check the integrity of the separation pliers (for withdrawable circuit-breaker).
7. The jaw contacts must be silvery in colour with no traces of erosion or discoloration.
8. Make sure that there are no foreign bodies in the circuit-breaker compartment.
9. Check for loose screws of the fixed part of the framework (M8 - 25Nm).

**Circuit-breaker connections
and connections between
circuit-breaker and
switchboard**

Perform the following checks on the connections:

1. Remove any dust or dirt with a brush and dry cloth (use a mild detergent if necessary. If there is a thick build-up of dirt, use a thinner from the greasing kit or ask for assistance from the service staff).
2. Make sure there are no traces of overheating on the terminals. Overheating is detected by a different coloration of the parts in contact; the contact parts are usually silvery white in colour.
3. Make sure that the bolts of the terminal connections are well tightened.



WARNING! if work must be performed on fixed circuit-breakers or on fixed parts, disconnect the power supply to the power circuit and auxiliary circuits and visibly earth the terminals on both the supply side and load side.

Disassembly operations To disassemble the parts of the circuit-breaker:

1. Remove the transparent flange (A) of the trip unit, by turning the screws (B).
2. Remove the front cover of the circuit-breaker (C), by removing the mounting screws (D).

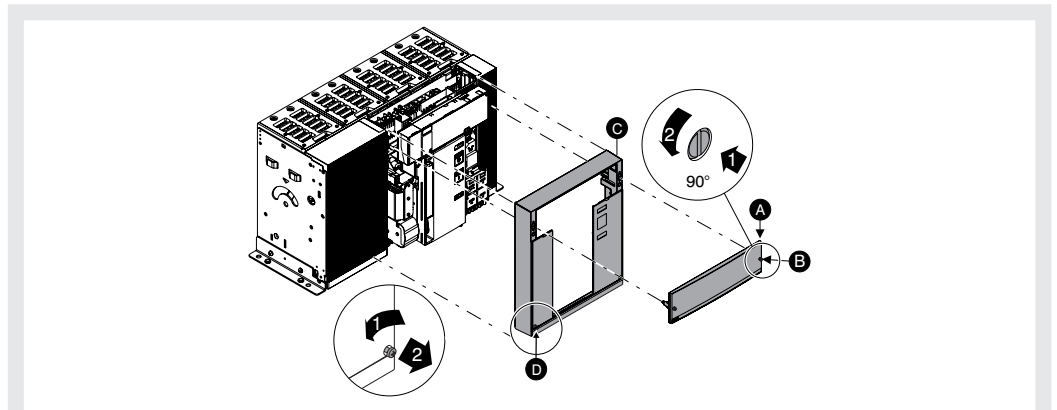

Figure 73 - Disassembly of flange and escutcheon plate

3. Remove one or both of the side guards (I) by removing the front screws (L).
4. Remove the gearmotor (E) by removing the screw (F) and the connector.

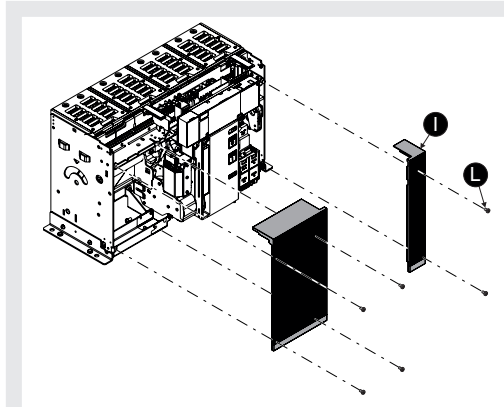

Figure 74 - Disassembly of the flange

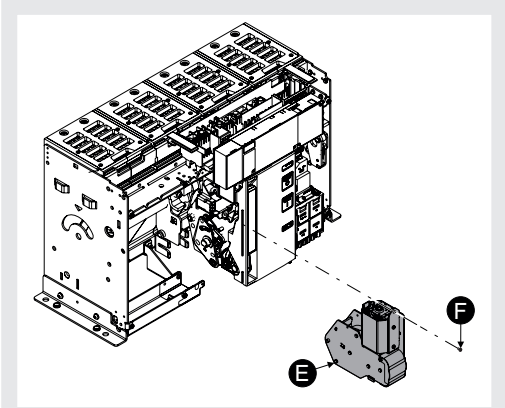

Figure 75 - Removing the gearmotor

5. If there is an undervoltage coil (G), remove it, and discharge the springs of the operating mechanism for closing and opening the circuit breaker.

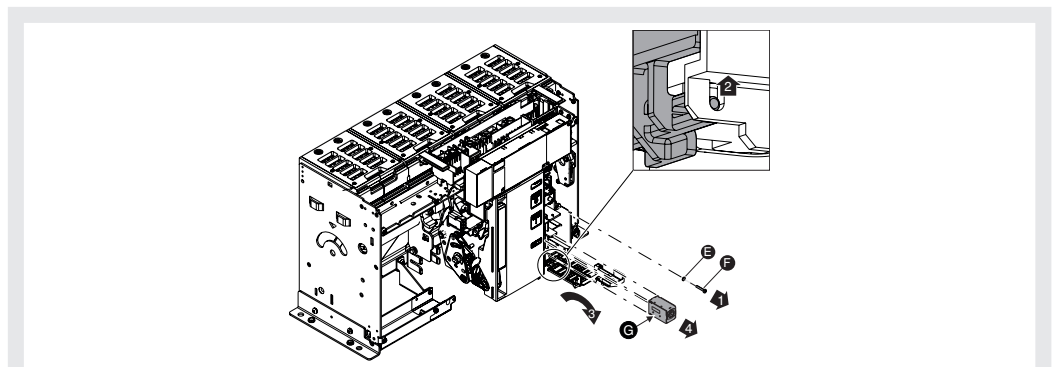

Figure 76 - Removing the undervoltage coil

Continued on the next page

- Remove the front cover of the circuit-breaker (e) by removing the screws (f) and the protection plate (g) by removing the screw (h).

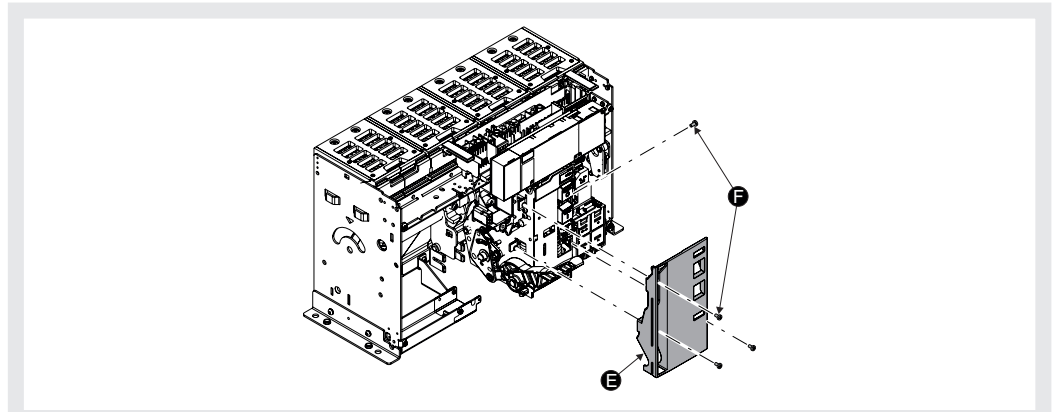

Figure 77 - Disassembly of the escutcheon plate

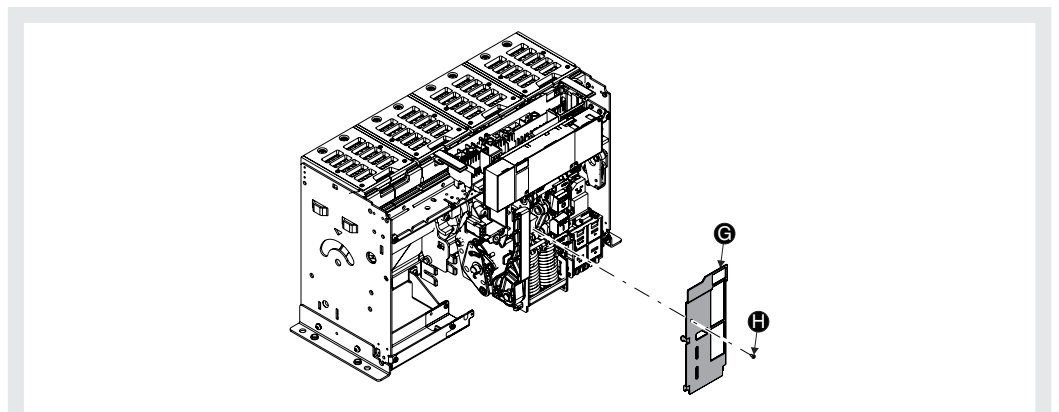

Figure 78 - Disassembly of the protection plate

Before cleaning and lubrication of the operating mechanism, you must remove the protection trip unit. For information about removal, see the document [1SDH001000R0523](#), or request the intervention of a technician ABB.

Cleaning and lubrication of the operating mechanism

To clean and lubricate:

1. Clean the closing clip, the closing rod and opening rod in the points shown in the illustrations. If there is a thick build-up of dirt, use a thinner from the greasing kit or ask for assistance from the service staff.
2. Lubricate closing hook, the closing shaft, opening hook and opening shaft in the points indicated by the illustrations with Mobilgrease 28 grease (EXXON MOBIL).
3. Make sure that the opening and closing shafts are free to turn.

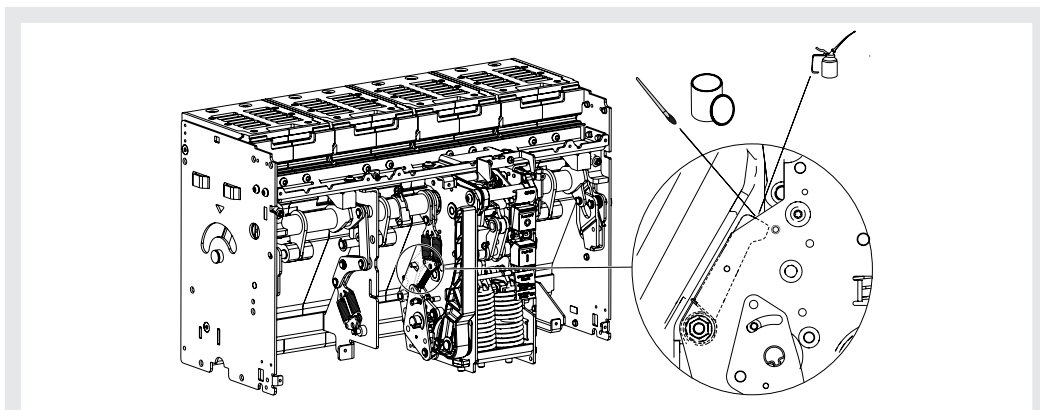

Figure 79 - Lubrication of closing latch and shaft

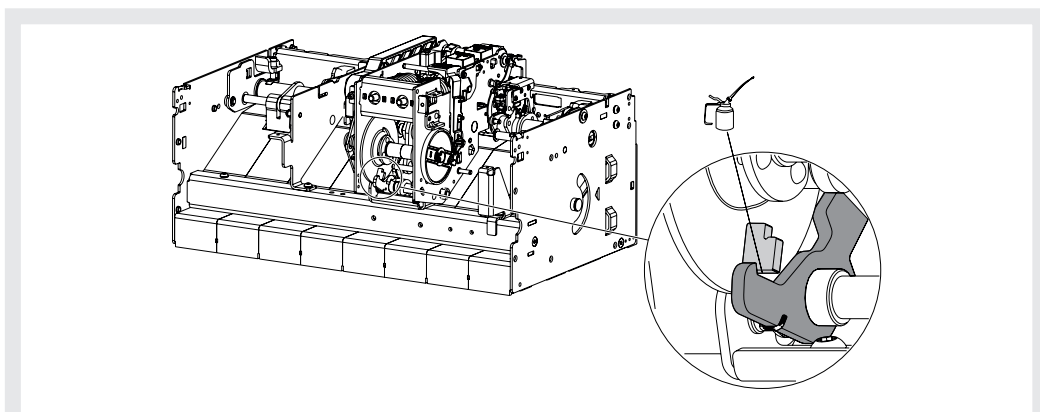

Figure 80 - Lubrication of the closing hook

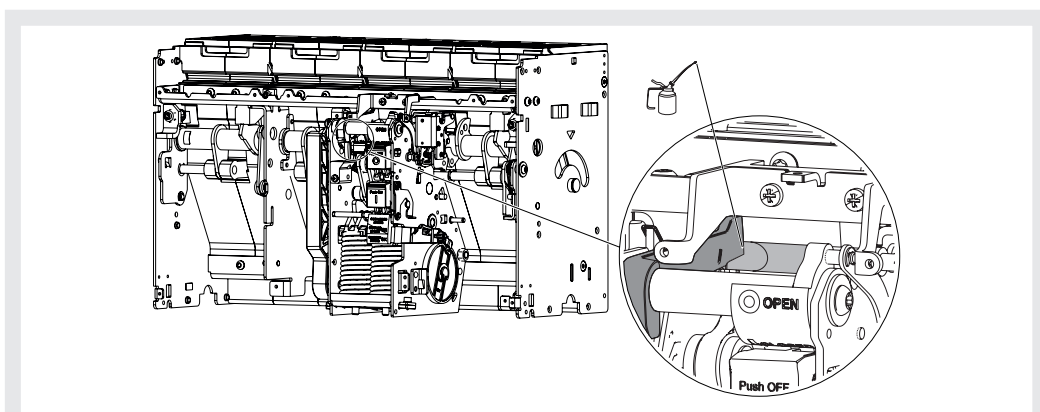

Figure 81 - Lubrication of opening latch and shaft

Continued on the next page

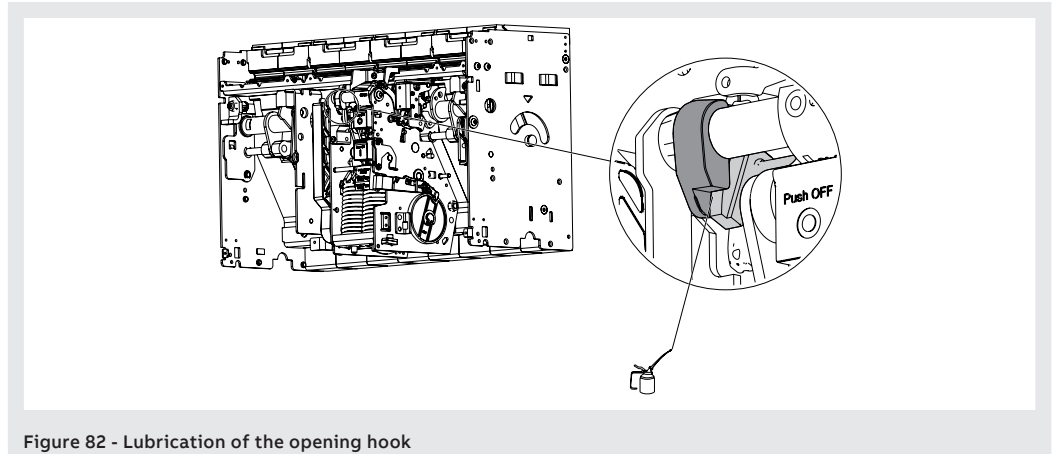

Figure 82 - Lubrication of the opening hook

- In the case of deformed or rusty springs, rings missing or severe wear of the operating device, contact ABB Sace.

Inspection of electrical and mechanical accessories

Check the accessories:

1. Check that the accessories are securely fixed to the circuit-breaker.
2. Check that the accessories are connected correctly to the circuit-breaker.
3. Make sure that the coils (YU-YO-YC) are in good condition (no excessive wear and tear, overheating, rupture).
4. Make sure that the mechanical operation counter functions correctly (if present) by operating the circuit-breaker.
5. Check the wear on the brushes of the gearmotor and if necessary replace them.



NOTE: it is advisable to replace the gear motor if it has performed more than 10000 spring charging operations or reached 50% of the declared mechanical life of the circuit-breaker.

Check for wear on the contacts

With the circuit-breaker open and springs discharged:

1. Remove the arc chutes

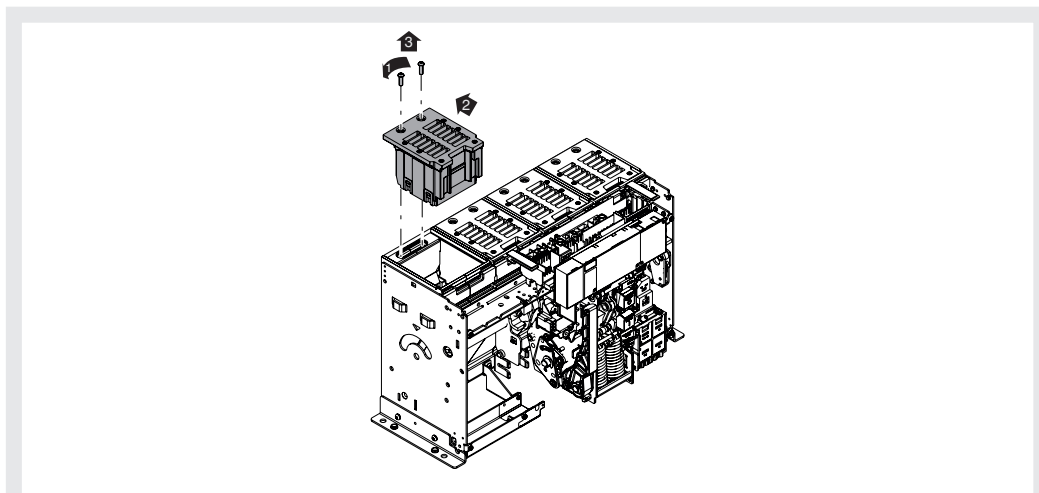

Figure 83 - Removing the arc chambers

2. Check the condition of the arc-breaking chutes: the base of the chute must be undamaged and the plates must be neither corroded nor indented.
3. Remove the dust with compressed air, then clean off all traces of fumes and slags with a brush.
4. Make sure that the contacts are in good condition.
5. Visually check to make sure that the main and arc-breaking plates are in place.
6. Check for tarnishing or beading. If such defects are discovered, ask for assistance from a qualified ABB Technician (*).
7. Check the arc-breaking gaps (dimension A).

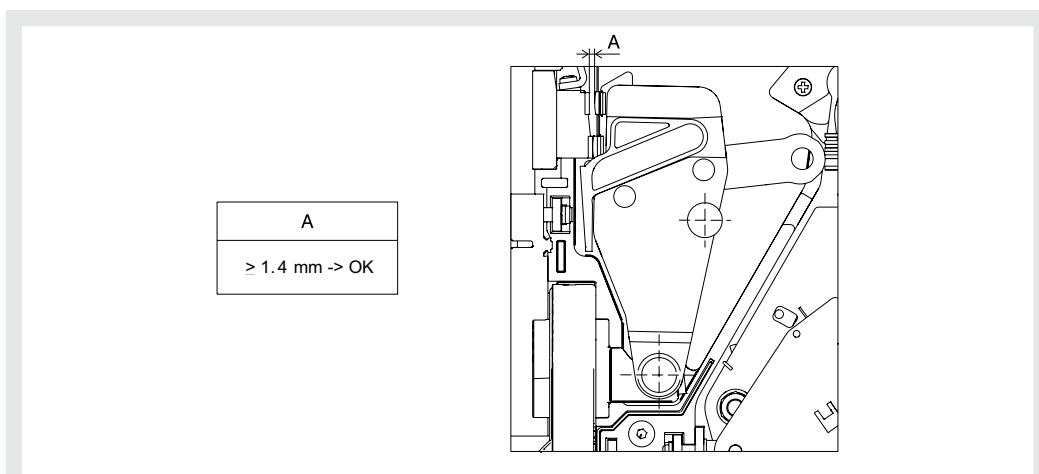

Figure 84 - Checking the breaking gaps

8. Close the circuit-breaker and check dimension A. Contact ABB Sace (*) if dimension A is incorrect. If dimension A is correct, open the circuit-breaker again and re-assemble the arc chutes.



NOTE: (*) After approval from the customer, ABB can proceed with replacement of the worn parts.

Final checks Reassemble and check the circuit-breaker:

1. Reassemble all the parts by performing all the operations indicated in the paragraph “Disassembly Operations” in reverse order. If necessary, reconnect the auxiliary power supply.
 2. Put the movable part (breakers) in the test position (see indication TEST).
 3. Perform the following operations 10 times:
 - Opening (in both local and remote modes, if applicable)
 - Closing (in both local and remote modes, if applicable)
 4. Perform the operations in the following sequence:
 - Open - Springs discharged
 - Open - Springs charged
 - Closed - Springs discharged
 - Closed - Springs charged
 5. Check that the following operate correctly:
 - accessories, if provided.
 - gearmotor, if provided.
 - undervoltage coil, if provided.
 - opening coil, if provided.
 - closing coil, if provided.
 - auxiliary contacts of the circuit-breaker, if provided.
 - lock for circuit-breaker in open position (key or padlock), if provided
-

Interlock check Check that the vertical or horizontal interlocking devices (if provided) are installed and that they operate correctly.



WARNING! the interlocks cannot be tested in the Test or Disconnected positions.

Perform maintenance periodically as indicated in the table below.

Activity	Frequency	Maintenance operations
Functionality	1 year or	See kit sheet
Check tightness	20% of mechanical life or	
Lubrication ^(*)	20% of electrical life	
Cables	Three years or 50% of the mechanical life or 50% of the electrical life of the largest circuit-breaker involved in the interlock. After a trip due to a short-circuit.	Replacement is advisable

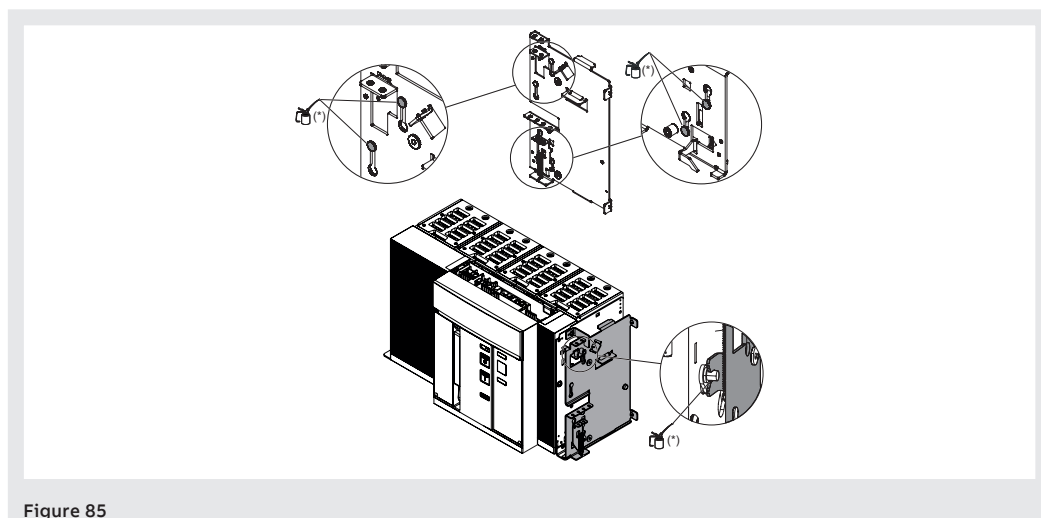

Figure 85

^(*) Use ABB greasing kit or grease of the Mobilgrease 28 type.

6 - Decommissioning and treatment at end of life

Safety standards During the early stages of the process of decommissioning and end of life treatment of SACE Emax 2 circuit-breakers, observe the following safety rules:

- the closing springs, even if discharged, must never to be taken apart.
- for handling and lifting of the circuit-breakers refer to the section "Unpacking and handling" on page 11 .



HAZARD! RISK OF ELECTRIC SHOCK! Unplug or disconnect any power supply, to avoid any potential risk of shock during removal of the circuit-breaker from the service.



WARNING! After dismantling the switchgear, the circuit-breaker must be stored in the open position with the closing springs discharged and with the front cover mounted.

Trained personnel The operations for decommissioning SACE Emax 2 circuit-breakers involve performing procedures that can be performed by Trained Persons in the electrical field (IEV 195-04-02: person adequately advised or supervised by electrically skilled persons to enable him or her to perceive risks and to avoid danger which electricity can create).

End of life treatment for circuit-breaker materials The materials used in the production of SACE Emax 2 circuit-breakers are recyclable and should be treated separately as shown in the following table:

TYPE	MATERIAL
A	Plastic parts ⁽¹⁾
B	Metal parts
C	Printed circuits
D	Current sensors, cables, motors, electrical windings

⁽¹⁾ All the components of significant dimensions bear a mark specifying the type of material.



NOTE: refer to the national legislation in force at the time of decommissioning of the product, in the case where it specifies end of life treatment procedures different from those indicated.

Disposal of packing materials The materials used for the packaging of SACE Emax 2 circuit-breakers are recyclable and should be treated separately as shown in the following table:

TYPE	MATERIAL
A	Plastic parts
B	Cardboard parts
C	Wooden parts
D	Metal parts



NOTE: refer to the national legislation in force at the time of decommissioning of the product, in the case where it specifies end of life treatment procedures different from those indicated.



We reserve the right to make technical changes or modify the contents of this document without prior notice. ABB does not accept any responsibility whatsoever for potential errors or possible lack of information in this document.

We reserve all rights in this document and in the subject matter and illustrations contained therein. Any reproduction, disclosure to third parties or utilization of its contents – in whole or in parts – is forbidden without prior written consent of ABB.

Copyright© 2025 ABB - All rights reserved.