

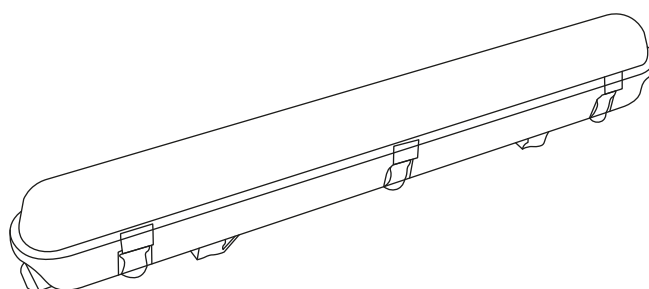

Read these instructions & save for future use

Waterproof lightbar | 664*90*90mm | IP65 | 10W | 5000K



Article number **950-080**

Brand **Tronix Lighting**

Type **Industrial lighting**

Contents of this product **1x 10W lightbar 5000K**

Technical datasheet **Digitally available
on our webshop**



*View instructions and
technical data also on
our website*

TRONIX



Before first use

Before getting started with this product, it is advisable to check the order completeness and any damage. If this is the case, please contact Tronix Lighting.

Description

These waterproof light bars are an ideal alternative to fluorescent fixtures. The PC cover has high light transmission and gives a nice uniform light output. The light bar comes with stainless steel clamps for easy installation and removal. Ideal for warehouses, factories and other areas with high dust release or high humidity.

Features

- High Lumen/Watt ratio >130 lm/w;
- 6063 aluminum mounting plate with perfect cooling;
- M20 cable gland with strain relief on both sides;
- Including stainless steel standard clamps.

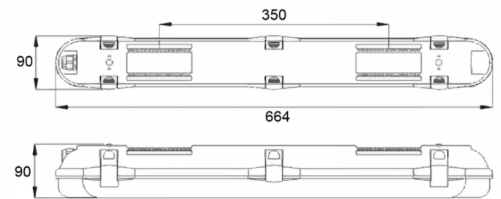

Installation

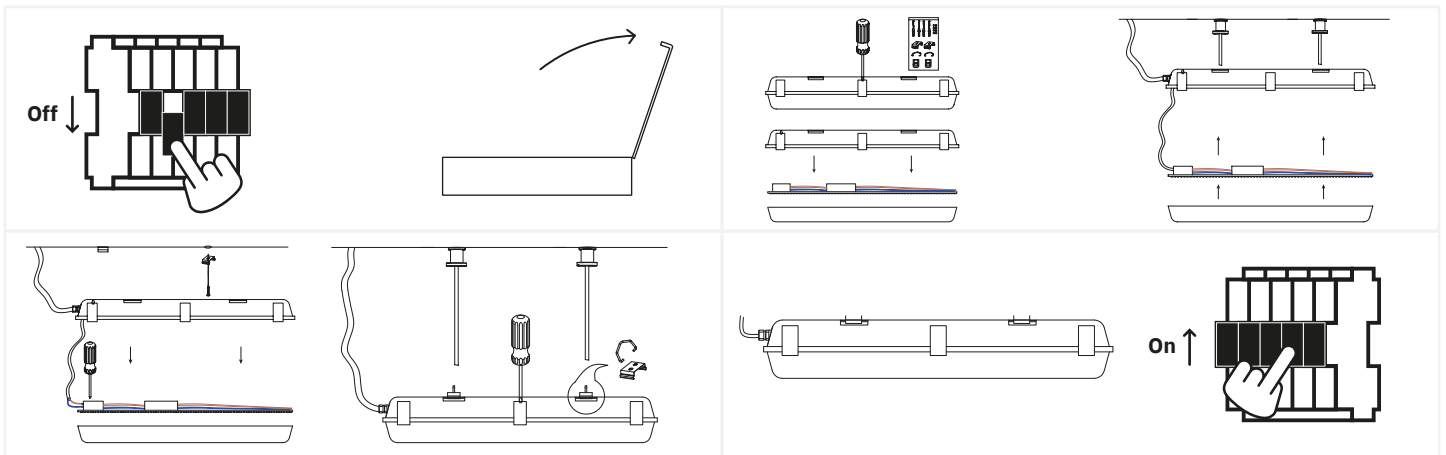

1. Turn off the power and remove the product and associated parts from the packaging...;
2. Disassemble the light bar and take out the accessories from the frame. Put the lightbar back together and connect the wiring;
3. Place the clamps to install the beam as surface-mounted, or use the cables if you want to leave the light bar hanging. Then attach the light bar to the chosen elements;
4. Check the installation and activate the power when it is OK.



Safety

Safety is a top priority at Tronix Lighting. Therefore, we heartily recommend that you follow the following steps closely:

- Keep this manual carefully for future reference;
- Choose a qualified electrician while installing, maintaining or inspecting this product;
- Never look directly into a light source to avoid possible damage to the eye;
- Always ensure that the relevant power group is on non-active when the product is connected;
- Use only recommended combinations (LED drivers, controllers or dimmers) to avoid injury or damage to the product.

Technical problems and repair

Should a product not work properly after installation, or if the product exhibits problems over time, it is advisable to check the following elements:

- Check the wiring and installation of your product;
- Check for the presence of interfering elements such as dust, water or other electronics;
- If possible, try disconnecting the product and testing it in another location to rule out a problem at the location;
- Should you be dealing with a WIFI-based product, check and reset your router's settings.

Should the product still not work after testing, it is recommended to send it in for inspection and/or repair. To do so, please contact Tronix Lighting using nearby details and proof of purchase (packing slip).



CARE



SHARE



CONNECT

Supplier:

Tronix Lighting B.V

Vluchtoord 41
5406 XP Uden, Netherlands

+31 (0)413 330 380
sales@tronixlighting.com

Terms and symbols (as relevant to product)



The **CE mark** indicates that this product complies with EU regulations on safety, health and environmental protection;



The **WEEE symbol** stands for "Waste Electrical and Electronic Equipment Regulation," a directive on the collection, recycling and recovery of electronic waste;



The **Class I symbol** indicates that this product is protected by means of the additional ground cable. This cable is identified by the yellow/green jacket and is attached to this product.

- This product has an **IP65 rating**. This means the housing is touch-safe, fully protected from dust and spray-proof (12.5 L/min) regardless of angle.