

## Battery LeakageStop Detector CWGA-0x/xx

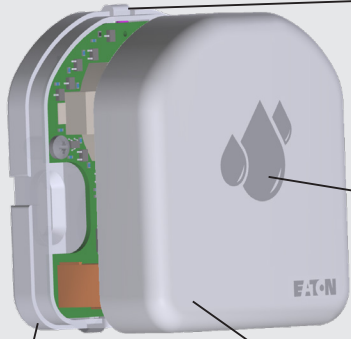

CWGA-00/01

CWGZ-CB/xx

On-device operating to acknowledge alarm

Battery 1x CR2477N  
Long battery service life

Onboard water sensor or  
with external sensor cable

Acoustic and LED alarm

Multi-Color Status LED

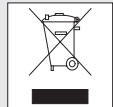
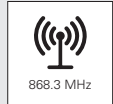

Device	Color
CWGA-0D/01	Pure white
CWGZ-CB/09	Cover Jet black
CWGZ-CB/03	Cover Silver

### Technical Data / Technische gegevens / Tekniske data / Technische Daten / Technická data

Power supply	
Battery	CR2477N 3Vdc
Battery service life	up to 5 years (TYP, when no alarm)
Alarm	LED and Acoustic
Push button	Alarm acknowledge
LED	Multi-Color operation status
Water sensor	
On device	2 contacts at the bottom
External	Flat-cable water sensor support
Dimensions	51 x 46 x 18 mm (H x W x D)
RF	868.3MHz (xComfort compatible)
Max RF power	25 mW (ERP)

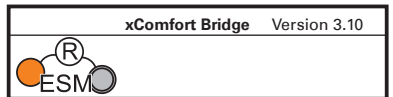
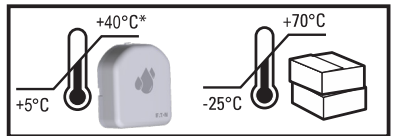

[www.eaton.com/LeakageStop](http://www.eaton.com/LeakageStop)

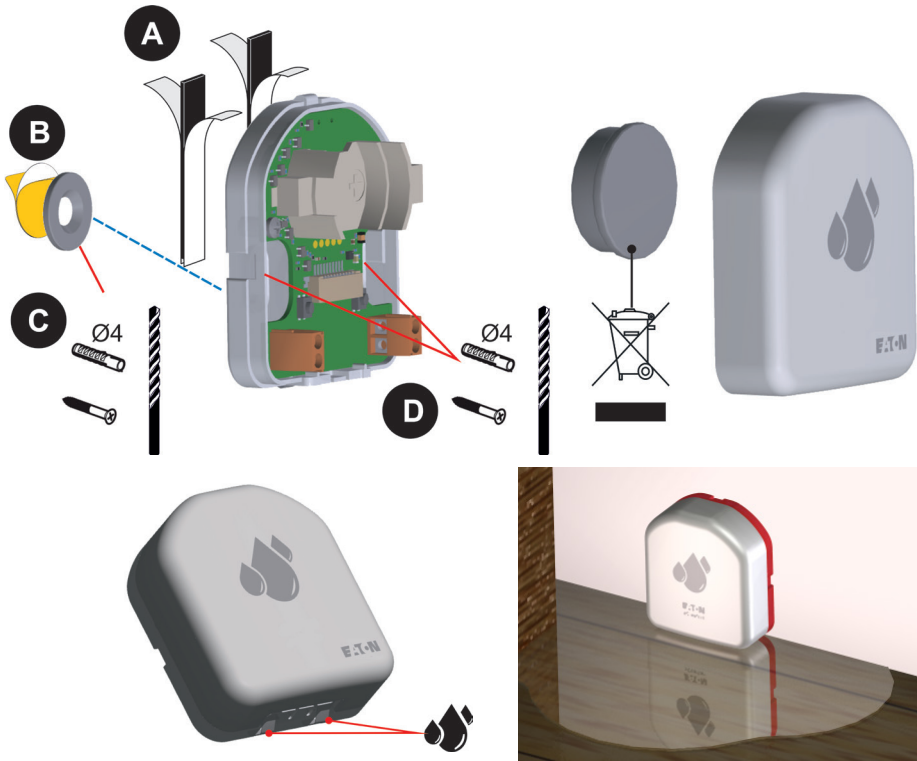

**Warning! Device contains a small battery (< 32 mm) and should not be installed in a location likely to be accessible to children. / Waarschuwing! Het apparaat bevat een kleine batterij (< 32 mm) en mag niet worden geïnstalleerd op een locatie die mogelijk toegankelijk is voor kinderen. / Advarsel! Enheten inneholder et lite batteri (< 32 mm) og bør ikke installeres på et sted som sannsynligvis er tilgjengelig for barn. / Warnung! Das Gerät enthält eine kleine Batterie (< 32 mm) und sollte nicht an einem Ort installiert werden, der für Kinder leicht zugänglich ist / Varování! Zařízení obsahuje malou baterii (< 32 mm) a nemělo by být instalováno na místě, které bude pravděpodobně přístupné dětem.**

**External sensor (optional) / Externe sensor (optioneel) / Ekstern sensor (valgfri) / Externer Sensor (optional) / Externí senzor (volitelně)**

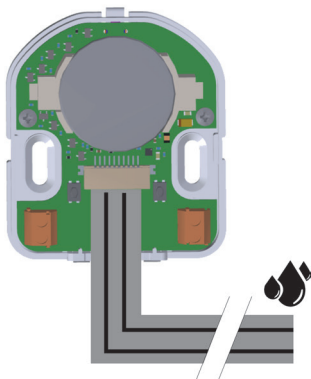

**Connect sensor cable / Sensorkabel aansluiten / Koble til sensorkabelen / Sensorkabel anschließen / Připojení kabelu senzoru**

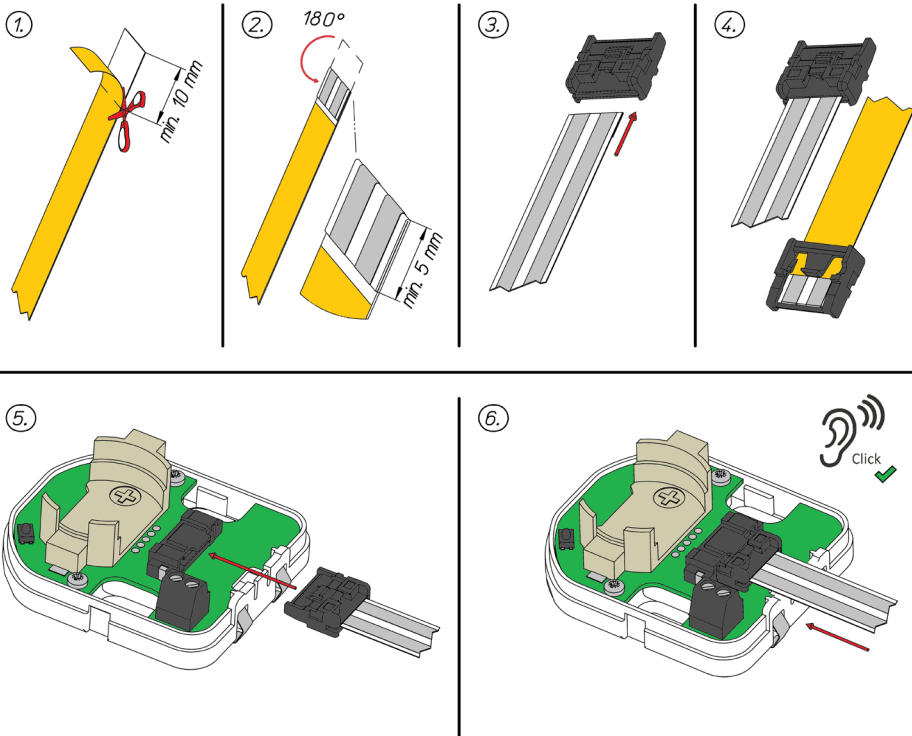

---

**How to apply the sensor cable / Hoe de sensorkabel aan te sluiten / Slik bruker du sensorkabelen / Anbringen des Sensorkabels / Jak instalovat kabel senzoru**

- **Surface must be clean, dry and dust-free / Ondergrond moet schoon, droog en stofvrij zijn / Overflaten må være ren, tørr og støvfri / Oberfläche muss sauber, trocken und staubfrei sein / Povrch musí být čistý, suchý a bezprašný**
- **Do not to touch the exposed adhesive area at any time / Raak het blootliggende kleefgedeelte nooit aan / Ikke berør det eksponerte limområdet / Den freiliegenden Kleberegich nicht berühren / Nedotýkejte se odkryté lepicí plochy**
- **Press firmly / Druk stevig aan / Trykk fast / Fest andrücken / Pevně přitlače**
- **Once mounted, the adhesive tape cannot be reused / Eenmaal gemonteerd, kan de tape niet opnieuw worden toegepast / Når den er monteret, kan ikke klebebåndet brukes på nytt / Nach der Montage kann das Klebeband nicht wieder verwendet werden / Po namontování nelze lepicí pásku znovu použít**

---

**Remove sensor cable / Sensorkabel verwijderen / Fjern sensorkabelen / Sensorkabel entfernen / Odpojení kabelu senzoru**

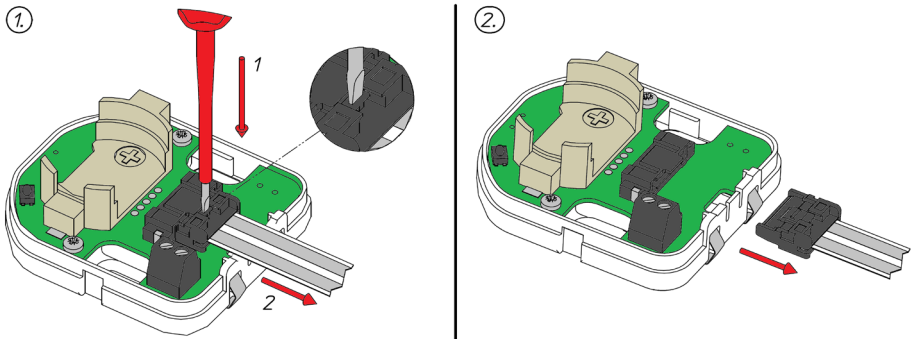

---

## Basic mode

**Connect LeakageStop Detector (Battery)** / LeakageStop-detector aansluiten (batterij) / Legg til LeakageStop Detektor (batteri) / LeakageStop-Detektor (Batterie) verbinden / Spárování detektoru zaplavení (bateriový)

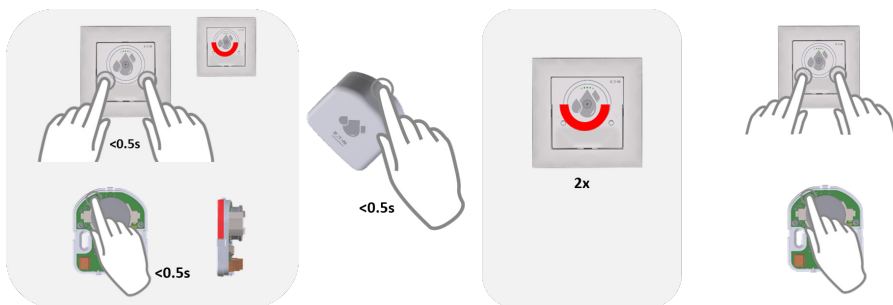

**Max. 5 LeakageStop detectors** / Max. 5 waterdetectoren / Maks. 5 vanddetektorer / Max. 5 Wassersensoren / Max. 5 detektorů zaplaveno

---

**Remove LeakageStop Detector (Battery)** / Verwijder de LeakageStop-detector (batterij) / Legg til LeakageStop Detektor (batteri) / LeakageStop-Detektor (Batterie) trennen / Odpárování detektoru zaplavení (bateriový)

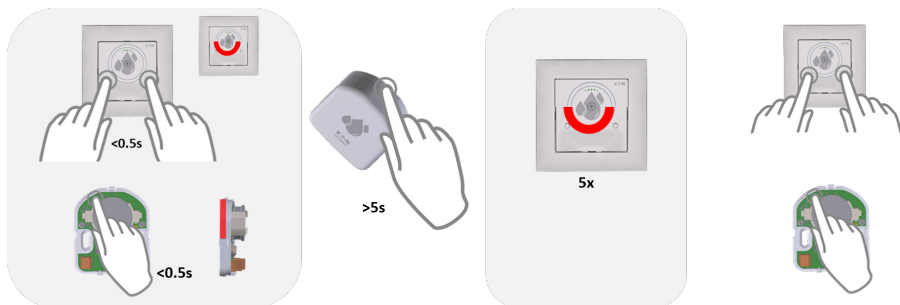

---

**Back to factory Default** / Terug naar fabrieksinstellingen / Tilbake til fabrikkinnstilling / Zurück zu den Werkseinstellungen / Uvedení do výrobního nastavení

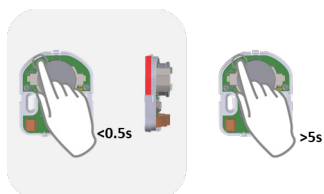

**LED during operation** / LED tijdens bedrijf / LED under drift / LED im Normalbetrieb / LED během provozu



X

X



X

X









**Replace battery** / Vervang batterij / Bytt batteri / Batterie wechseln / Vyměnit baterii



**No RF communication** / Geen RF-communicatie / Ingen RF-kommunikasjon / Keine Funk-Kommunikation / Žádná RF komunikace

# xComfort LeakageStop

What to do if water is detected:

		
<b>1</b>	<b>Reset the sound alert by briefly (&lt;0.5s) pressing button <b>A</b>.</b>	
<b>2</b>	<b>Check for water leakage. Make sure that the installation site is dry and in order.</b>	
<b>3</b>	<input type="checkbox"/> <b>Used with main LeakageStop device. To open the water valve, follow the steps for the main LeakageStop device.</b>	
	Location: <input type="text"/>	



# Declaration of Conformity

We, **EATON Industries (Austria) GmbH**  
3943 Schrems, Eugenia 1  
Austria

declare under our sole responsibility as manufacturer that the product (family)

## Eaton - Battery LeakageStop Detector

### CWGA-00/01

(the declaration of conformity applies to all listed types within our actual product catalogue)

provided that it is installed, maintained and used in the application intended for, with respect to the relevant manufacturer's instructions, installation standards and "good engineering practices"

complies with the provisions of Council directive(s):

RED Directive 2014/53/EU

RoHS Directive 2011/65/EU + 2015/863

based on compliance with following standard(s):

EN 300220-2 V3.2.1, EN 301 489-1 V2.2.3, EN 301489-3 V2.1.1, EN IEC 63044-5-1:2019, EN IEC 63044-5-2:2019, EN IEC 63044-5-3:2019, EN IEC 62368-1:2020 + A11:2020, EN 63000:2018



Gerhard Dischner

Director Operations

Schrems, 11.11.2021

Friedrich Schröder

Director Quality

Doc.Id.: CWGA\_00-01\_111121

