

## Data Sheet | Item Number: 771-9393/216-202

pre-assembled connecting cable; Dca; Plug/open-ended; 3-pole; Cod. A; H05Z1Z1-F 3G 1.5 mm<sup>2</sup>; 2 m; 1,50 mm<sup>2</sup>

<https://www.wago.com/771-9393/216-202>

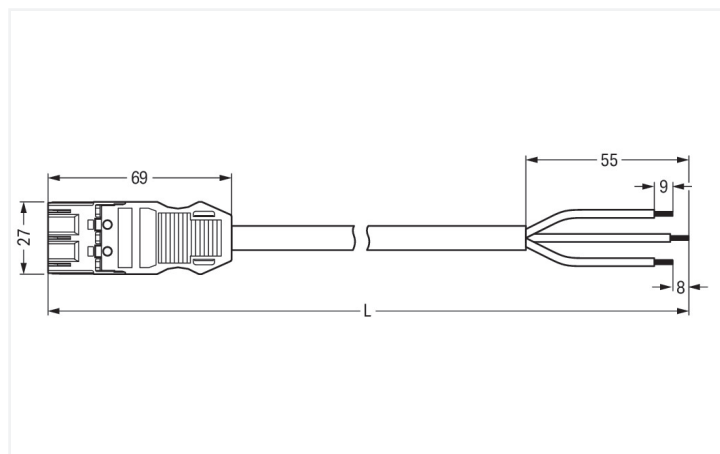
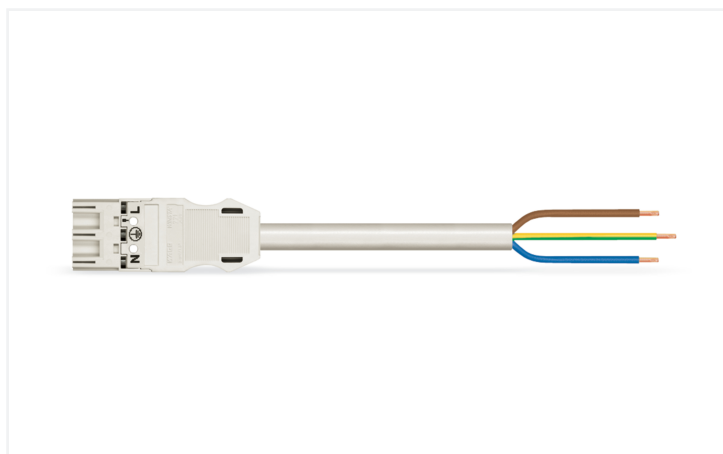

Dimensions in mm

### Cable assembly WINSTA® MIDI with protection type IP20

The WINSTA® MIDI cable assembly with protection type IP20 is the pluggable solution for your application in control cabinets, for lighting connections or on PCBs. Whether on PCBs, in control cabinets or for connecting lights – pluggable installation connectors from WAGO allow you to make connections according to various requirements in seconds. The pluggable installation connector is protected against ingress by solid objects in accordance with protection type IP20 (When mated: IP2xC (These compact connectors are not designed for use in open, easily accessible areas!)). General mains applications for almost any domain of use can be realised with WINSTA® MIDI pluggable installation connectors with A coding. The WINSTA® MIDI Pluggable Connection System with Push-in CAGE CLAMP® spring pressure connection technology facilitates precise electrification. Thanks to the included test slot, it is possible to check connections even when they are plugged in. This saves time, labor, and money. In the production of this cable assembly, halogens were deliberately omitted. This is an important contribution to climate protection.

### Fast, error-free assembly thanks to cable assemblies from WAGO

A plug and a free end are available. The WINSTA® Pluggable Connection System allows pluggable electrical installation. This significantly reduces the need for servicing and lowers costs. Choose durability and quality – with strain relief hosting from WAGO makes the installation of electrical components noticeably easier.

- pre-assembled versions
- with A coding for a large number of applications
- custom-engineered solutions
- fast, secure installation

### Notes

Note Cables with a different fire class can be found in the eShop.

### Electrical data

#### Ratings per IEC/EN

Ratings per	IEC/EN 60664-1
Nominal voltage (III/3)	250 V
Rated impulse withstand voltage (III / 3)	4 kV
Rated current	16 A
Legend (ratings)	(III / 3) ± Overvoltage category III / Pollution degree 3

#### General information

Note on contact resistance	approx. 1 mΩ of contact resistance approx. 0.25 mΩ contact transition plug/ socket
----------------------------	--

## Connection Data

Total number of potentials	3
PE function	Preceding PE contact
Conductor preparation	ultrasonically tip-bonded

### Connection 1

Strip length	9 mm / 0.35 inches
Pole number	3
Wire cross-section	1.5 mm <sup>2</sup>
Strip length (outer insulation)	55 mm
Connection type	Plug - free end

## Physical data

Pin spacing	10 mm / 0.394 inches
Width	27 mm / 1.063 inches
Height	12.9 mm / 0.508 inches
Total length	2 m

## Mechanical data

Use	General mains applications
Coding	A
Variable coding	Yes
Marking	L ⊕ N
Potential marking	L ⊕ N
Mating force of a plug-in connection	approx. 20 ... 70 N (depending on pole number)
Retention force of a plug-in connection	when locked: > 80N
Unmating force of a plug-in connection	when unlocked: approx. 20 ... 70 N (depending on pole number)
Number of mating cycles	200, without resistive load
Connection type	Plug - free end
Type of pre-assembled cable	Connecting cable
Cable type	H05Z1Z1-F 3G1.5
Protection type	IP20; When mated: IP2xC (These compact connectors are not designed for use in open, easily accessible areas!)

## Plug-in connection

Mismating protection	Yes
Note on mismating protection	All WINSTA® components are 100% protected against mismating when: a.) plugging different numbers of poles b.) plugging while rotated 180 c.) plugging while laterally staggered d.) plugging one pole
Locking lever	Can be retrofitted
Locking of plug-in connection	Locking lever
Note on locking system	All connectors for mounted installations (snap-in versions for lighting fixtures or devices, all types of PCB and distribution connectors) are factory-equipped with locking levers to ensure plugs and sockets are securely locked. Additional locking levers are only required for flying leads (plug/socket).

### Material data

Note (material data)	<a href="#">Information on material specifications can be found here</a>
Insulation material (main housing)	Polyamide (PA66)
Flammability class per UL94	V0
Fire class per EN 50575	D <sub>ca</sub>
Contact material	Copper or copper alloy; surface-treated
Contact Plating	Tin
Fire load	0.328 MJ
Connector color	white
Strain relief color	white
Printing color of strain relief	black
Sheathed cable color	white
Printing color of sheathed cable	black
Halogen-free	Yes
Silicon-free	Yes
Sheath material	Halogen-free
Rubber cable	No
Weight	212.3 g
Copper weight of the raw cable	0.043 kg/m

### Environmental requirements

Processing temperature	-5 ... +40 °C
Continuous operating temperature	-35 ... +85 °C
Note on continuous operating temperature	Cable for temperatures ≤ 70 °C (including halogen-free) Insulating parts for temperatures ≤ 105 °C

### Commercial data

PU (SPU)	1 pcs
Packaging type	unpacked
Country of origin	PL
GTIN	4066966710649
Customs tariff number	85444290900

### Product Classification

ETIM 9.0	EC002587
ETIM 10.0	EC002587
ECCN	NO US CLASSIFICATION

### Environmental Product Compliance

RoHS Compliance Status	Compliant, No Exemption
------------------------	-------------------------

Downloads

Environmental Product Compliance

Compliance Search

Environmental Product Compliance  
771-9393/216-202



1 Compatible Products

1.1 Required Accessories

1.1.1 Locking system

1.1.1.1 Locking system



[Item No.: 770-101](#)

Locking lever; for flying leads; for manual operation; black



[Item No.: 770-121](#)

Locking lever; for flying leads; for manual operation; white



[Item No.: 770-111](#)

Locking lever; for flying leads; for tool operation; black



[Item No.: 770-131](#)

Locking lever; for flying leads; for tool operation; white

1.2 Optional Accessories

1.2.1 Cover

1.2.1.1 Cover



[Item No.: 770-360](#)

Lockout cap; for plugs; 5-pole; separable; yellow



[Item No.: 897-2003](#)

Protective cap; Type2; for sockets and plugs; PVC; red

1.2.2 Installation

1.2.2.1 Mounting accessories



[Item No.: 770-310](#)

Mounting carrier; 2- to 5-pole; for flying leads; black

1.2.3 Marking

1.2.3.1 Marker



[Item No.: 770-450/000-006](#)

Marker card; Plastic; blue



[Item No.: 770-450/000-001](#)

Marker card; Plastic; green



[Item No.: 770-450/000-012](#)

Marker card; Plastic; orange



[Item No.: 770-450/000-005](#)

Marker card; Plastic; red



[Item No.: 770-450](#)

Marker card; Plastic; white



[Item No.: 770-450/000-002](#)

Marker card; Plastic; yellow

### 1.2.3.2 Marking strip



**Item No.: 210-334**

Marking strips; as a DIN A4 sheet; Strip width 5 mm; Strip length 182 mm; plain; Self-adhesive; white