

## 600-022 Recessed Kit installation instruction Model No.: 600-030

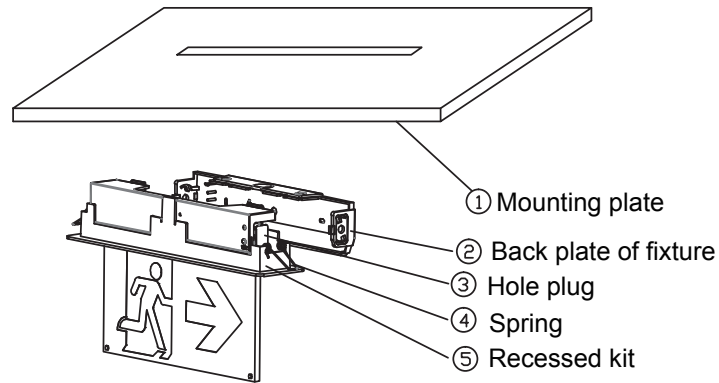

### Installation

FIG.1

Make a cut out hole, dimension 360mm\*55mm, the thickness of mounting plate 10-20mm.

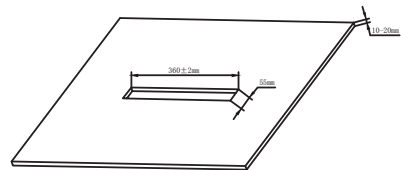

FIG.2

Remove the back plate from fixture 600-022, then remove cap at test switch side.

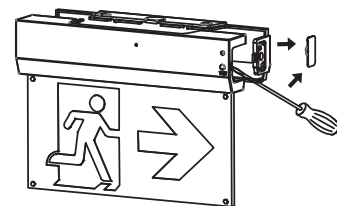
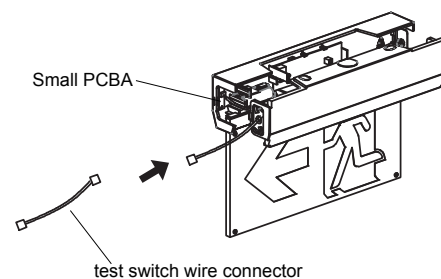

FIG.3

Connect the test switch wire connector on small PCBA inside the luminaire.



---

FIG.4

Connect AC power supply wire according to the exit sign instruction sheet and assemble back plate back to the exit sign. Assemble exit sign on recessed kit, pay attention to the direction of fixture. Connect test switch wire connector to the small PCBA on the recessed kit.

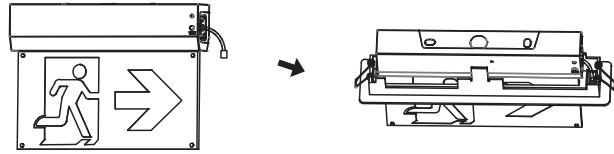

---

FIG.5

Rotate spring to up, press the fixture recessed kit on mounting plate, press in one side then another.

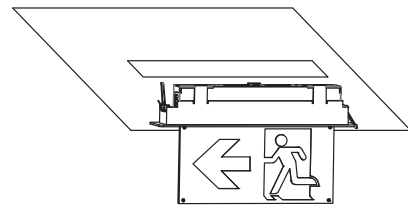

---

FIG.6

Finish installation

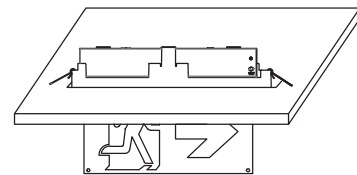

---

***Instruction for dismounting the fixture.***

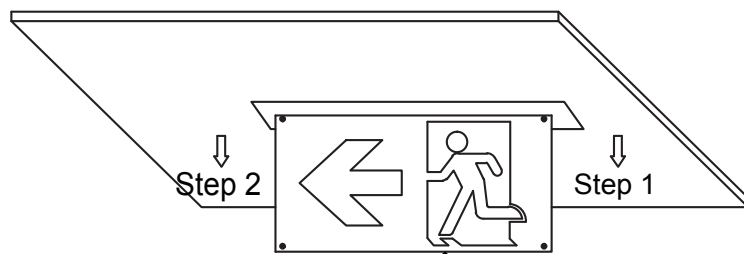

Pull out fixture from one side then another side.

---