

DE Montagefüße BetteLevel für Duschen > 1000 mm  
EN Installation feet BetteLevel for showers > 1000 mm  
FR Pieds de montage pour douches > 1000 mm  
NL Montagepoten BetteLevel voor douches > 1000 mm

DE Montageanleitung  
EN Installation instruction  
FR Instructions de montage  
NL Montagehandleiding

B57-0421  
B57-0422



**BETTE**



## Symbolerklärung



Ersatzteil



Achtung



Verweis auf andere Produkte oder Dokumentationen



Verweis auf eine andere Seite in diesem Dokument



Korrekte Montage



Falsche Montage



Optional



Fliesen- und Plattenarbeiten



Montagetip

## Einsatzbereich

B57-0421: BetteLevel Montagefüße für Duschen mit einer Seitenlänge > 1.000 mm

B57-0422: BetteLevel Montagefüße für Duschen mit beiden Seitenlängen > 1.000 mm

Beide Sets sind nicht kombinierbar mit den BetteAir Duschfliesen sowie BetteDelta und BetteQinta Duschwannen.

## Sicherheitshinweise

- Eine Gewährleistung in Bezug auf Sicherheit, Funktion und Unversehrtheit des Produkts ist nur gegeben, wenn die Hinweise in dieser Anleitung beachtet werden. Bei Missachtung können Körperverletzungen und Sachschäden auftreten. Der Hersteller haftet nicht für Schäden, die durch Nichtbeachtung der Anweisungen eintreten.
- Gehen Sie unbedingt nach der Anweisung der Montageanleitung vor, um Montagefehler und Schäden am Produkt zu vermeiden.
- Beachten Sie neben den Hinweisen in dieser Anleitung die allgemein gültigen Sicherheits- und Unfallvorschriften.

## Hinweise zur Anleitung

- Diese Montageanleitung muss während der gesamten Montage zur Verfügung stehen. Wenn die Montage von verschiedenen Personen (z.B. Installateur, Fliesenleger) durchgeführt wird, muss die Montageanleitung übergeben werden.
- Vorhandene Maßangaben sind in Millimeter (mm) angegeben.
- Die Abbildungen sind nicht maßstabsgerecht.
- Technische Änderungen sind vorbehalten.

## Montagehinweise

- Die Montage darf nur durch qualifiziertes Fachpersonal erfolgen.
- Behandeln Sie das Produkt mit größter Sorgfalt, um Beschädigungen zu vermeiden. Ringe und andere Gegenstände, die das Produkt beschädigen können, müssen vor der Montage abgelegt werden.
- Schwere und sperrige Elemente müssen mit zwei Personen bewegt und montiert werden.
- Fliesen- und Plattenarbeiten müssen gemäß der DIN 18157 durchgeführt werden.
- Für die Höhe der Füße muss der Abstand Rohfußboden bis zur Oberkante Fertigfußboden (Abkürzung „OKFF“, wird durch den bauseits vorhandenen Meterriss festgelegt) ermittelt werden. → Stärke Dämmung + Estrich + Verbundabdichtung + Fliesenkleber + Bodenfliese



Beachten Sie auch separate Dokumentationen (z. B. für Ablaufgarnituren).

### Meaning of symbols



Spare part



Caution



Cross reference to other products or documentation



Cross reference to another page in this document



Correct installation



Incorrect installation



Optional



Large and small format tiling work



Installation tip

### Area of application

B57-0421: BetteLevel installation feet for showers with a side length > 1,000 mm

B57-0422: BetteLevel installation feet for showers with both sides > 1000 mm

Both sets cannot be combined with BetteAir shower tiles or BetteDelta and BetteQinta shower trays.

### Safety information

- The safety, function and integrity of the product can only be guaranteed if the information provided here is observed. Failure to do so may result in injury or damage to persons or property. The manufacturer is not liable for any damage resulting from a failure to observe the instructions.
- It is essential that you follow the instructions given in the installation guide in order to prevent installation errors and damage to the product.
- Please observe the general safety and accident prevention regulations in addition to the information provided in these instructions.

### About this guide

- This installation guide must be available for the entire duration of the installation process. If the installation is to be carried out by several individuals (e.g. fitter, tiler etc.), then the installation guide must be passed on as appropriate.
- The dimensions are given in mm (millimetres).
- The illustrations are not true to scale.
- Subject to technical changes.

### Installation information

- Only to be installed by qualified specialists.
- Handle the product with the greatest care in order to prevent damage. Rings and other items that could damage the product must be removed before installation.
- Heavy and bulky elements must be moved and assembled with two people.
- Large and small format tiling work should be performed pursuant to DIN 18157.
- For the height of the feet, the distance from the unfinished floor to the upper edge of the finished floor (abbreviation „OKFF“, is determined by the metre plan available on site) must be determined. → Thickness insulation + screed + bonded waterproofing + tile adhesive + floor tile



Please also observe the separate documentation (e.g. for waste fittings).

## Légende



Pièce détachée



Caution



Référence aux autres produits ou documentations



Référence à une autre page dans ce document



Montage correct



Montage incorrect



En option



Pose de carrelage et de dallage



Conseil de montage

## Domaine d'application

B57-0421: Pieds de montage BetteLevel pour douches avec une longueur de côté > 1.000 mm

B57-0422: Pieds de montage BetteLevel pour douches avec deux côtés > 1000 mm

Les deux kits ne sont pas compatibles avec les receveurs de douche BetteAir ainsi que les receveurs de douche BetteDelta et BetteQinta.

## Consignes de sécurité

- La sécurité, la fonctionnalité et l'intégrité du produit ne sont garanties que si les consignes fournies dans ce manuel sont respectées. Tout manquement à ce point peut entraîner des blessures corporelles et des dommages matériels. Le fabricant décline toute responsabilité pour les dommages survenus du fait du non respect des instructions.
- Procédez strictement comme indiqué dans le manuel de montage pour éviter toute erreur de montage et tout dommage du produit.
- Outre les consignes du présent manuel, tenez compte également des dispositions généralement en vigueur en matière de sécurité et de prévention des accidents.

## Instructions

- Les présentes instructions doivent être disponibles durant tout le montage. Lorsque le montage est effectué par différentes personnes (par ex. installateur, carreleur), les instructions de montage doivent être transmises.
- Les cotes sont indiquées en millimètres (mm).
- Les illustrations ne sont pas à l'échelle.
- Subject to technical changes.

## Instructions de montage

- Le montage ne doit être réalisé que par du personnel qualifié.
- Manipulez le produit avec la plus grande précaution afin d'éviter tout dommage. Les bagues et autres objets susceptibles d'endommager le produit doivent être retirés avant le montage.
- Les éléments lourds et encombrants doivent être déplacés et montés par deux personnes.
- Veuillez réaliser la pose du carrelage et du dallage conformément à DIN 18157.
- Pour la hauteur des pieds, il faut déterminer la distance entre le sol brut et l'arête supérieure du sol fini (abréviation „OKFF“, est déterminée par le plan métrique disponible sur le chantier). → épaisseur de l'isolation + chape + étanchéité composite + colle à carrelage + carrelage de sol



Tenez compte des différentes documentations (par ex. pour l'évacuation).

### Uitleg van de symbolen



Reserveonderdeel



Let op



Verwijzing naar andere producten  
of documentatie



Verwijzing naar een andere pagina  
in dit document



Correcte montage



Verkeerde montage



Optioneel



Tegel- en plaatwerkzaamheden



Installatietip

### Toepassingsgebied

B57-0421: BetteLevel montagepoten voor douches met een zijlengte > 1.000 mm

B57-0422: BetteLevel montagepoten voor douches met beide zijlengtes > 1000 mm

Beide sets zijn niet te combineren met BetteAir douchetegel, of BetteDelta en BetteQinta douchebakken.

### Veiligheidsinstructies

- Er is alleen sprake van een garantie met betrekking tot veiligheid, functie en intactheid van het product, als de opmerkingen in deze handleiding in acht worden genomen. Bij niet-naleving kunnen lichamelijk letsel en materiële schade optreden. De producent is niet aansprakelijk voor schade die door het niet in acht nemen van de aanwijzingen optreedt.
- Ga absoluut te werk volgens de aanwijzingen in de montagehandleiding, om montagefouten en schade aan het product te voorkomen.
- Neem naast de instructies in deze handleiding de algemeen geldige veiligheids- en ongevallenvoorschriften in acht.

### Opmerkingen bij de handleiding

- Deze montagehandleiding moet tijdens de hele montage ter beschikking staan. Als de montage door verschillende personen (bijv. installateur, tegellegger) wordt uitgevoerd, moet de montagehandleiding overhandigd worden.
- Bestaande maataanduidingen zijn in millimeter (mm) aangegeven.
- De afbeeldingen zijn niet schaalgetrouw.
- Technische wijzigingen zijn voorbehouden.

### Montage-instructies

- De montage mag uitsluitend door gekwalificeerd vakpersoneel plaatsvinden.
- Behandel het product uiterst zorgvuldig om beschadigingen te voorkomen. Ringen en andere voorwerpen die het product kunnen beschadigen, moeten vóór de montage worden afgedaan.
- Zware en omvangrijke elementen moeten met twee personen worden verplaatst en gemonteerd.
- Tegel- en plaatwerkzaamheden moeten conform DIN 18157 worden uitgevoerd.
- Voor de hoogte van de poten moet de afstand van de onafgewerkte vloer tot de bovenkant van de afgewerkte vloer (afkorting „OKFF“, wordt bepaald door het ter plaatse beschikbare meterpeil) worden bepaald. → Dikte isolatie + dekvloer + verlijmde waterdichting + tegellijm + vloertegel



let ook op de separate documentatie  
(bijv. voor afvoergarnituren).

DE Lieferumfang  
 EN Scope of delivery  
 FR Contenu de la livraison  
 NL Leveringsomvang

**B57-0421**  
 1x

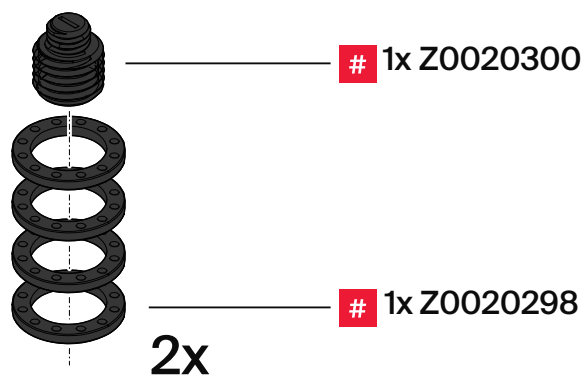
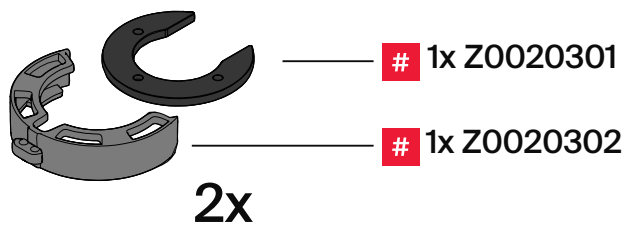
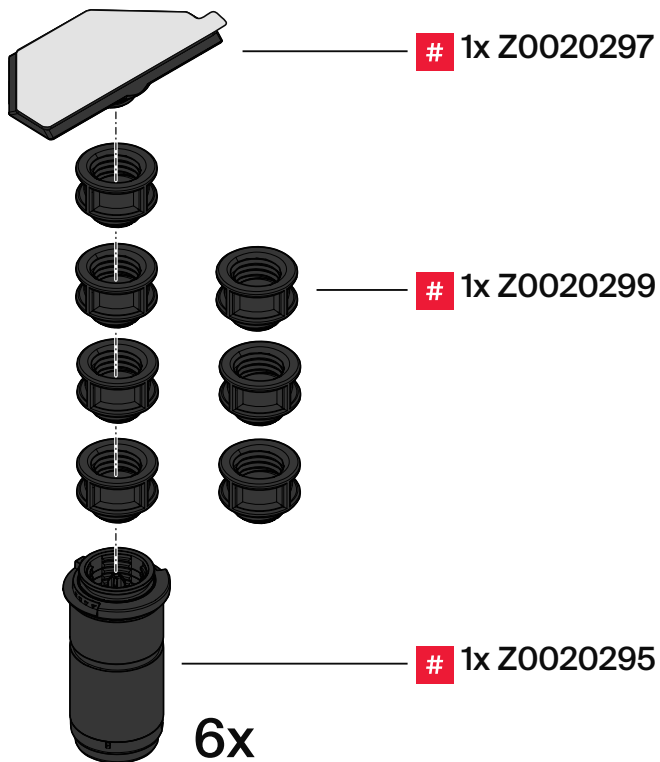

**B57-0422**  
 1x

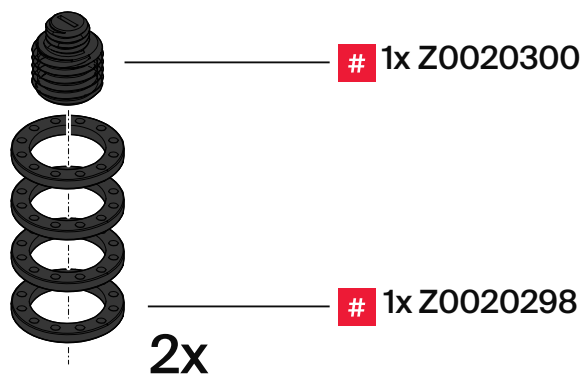
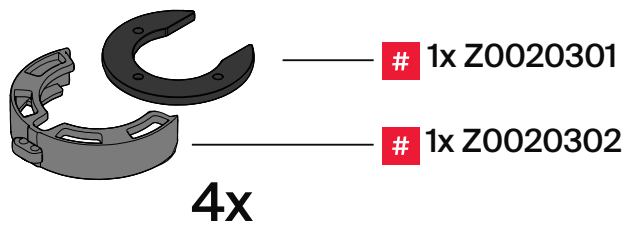
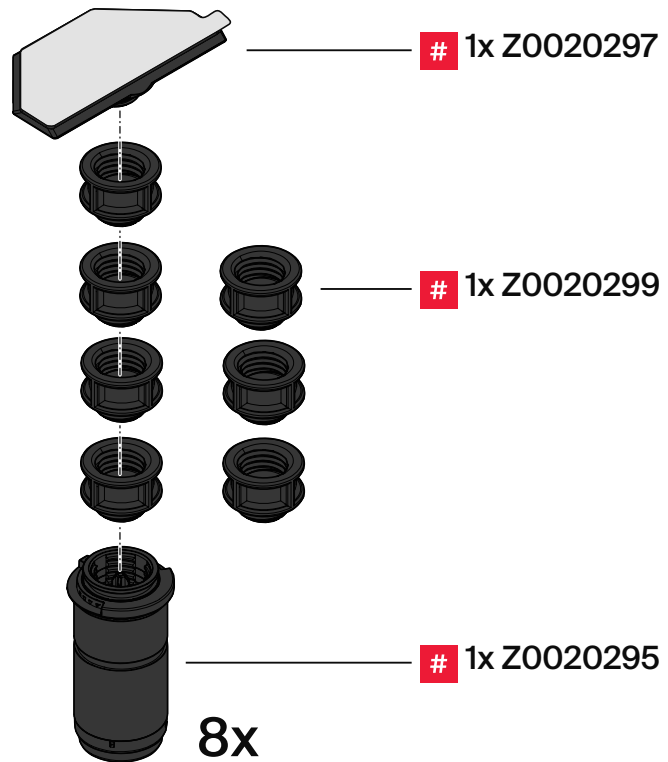



**B57-0424**  
1x

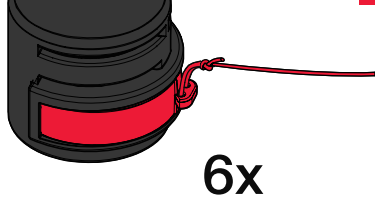
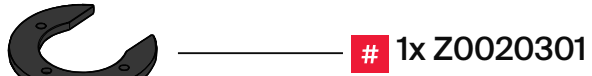

min.

max.

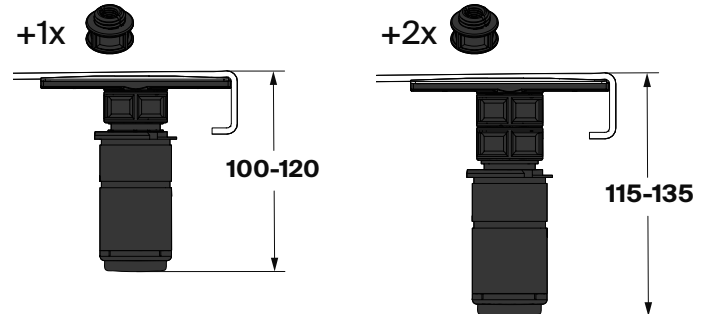
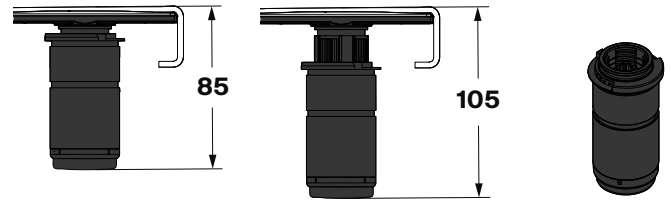

**B57-0425**  
1x

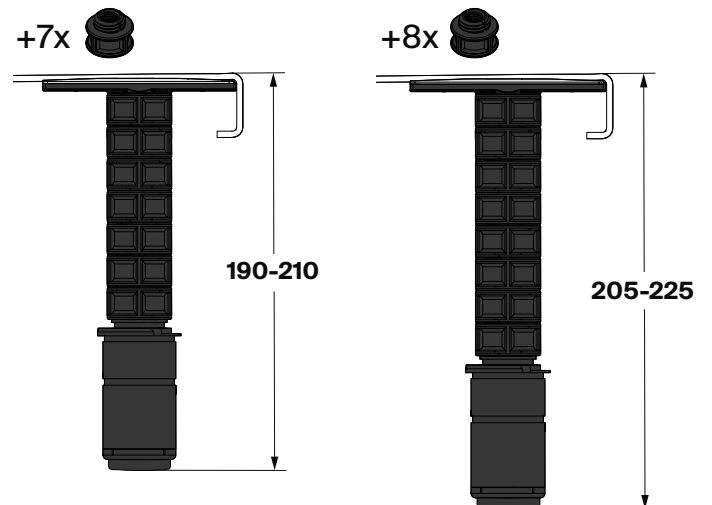
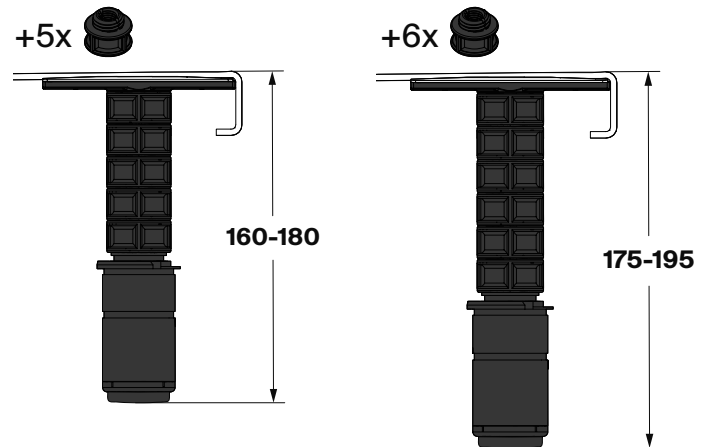
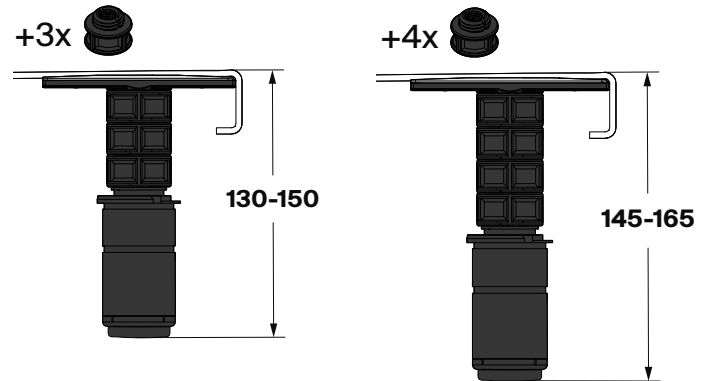
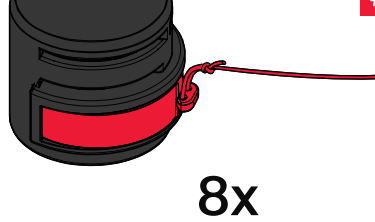
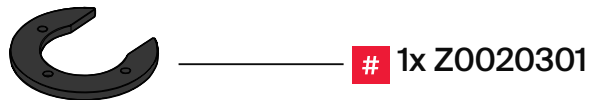



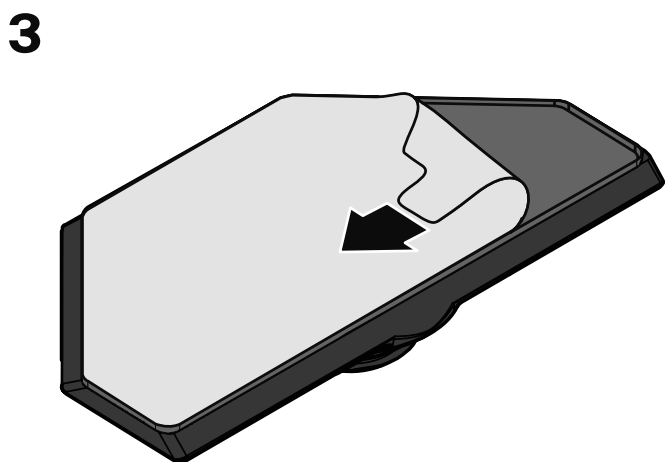
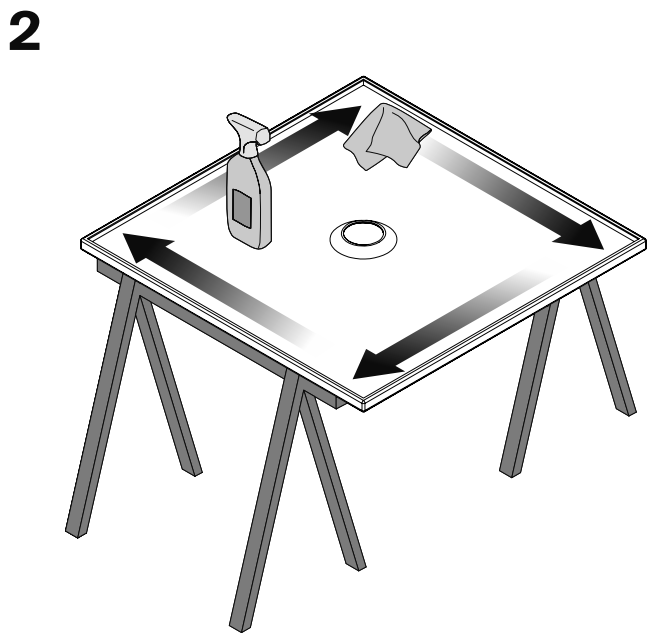
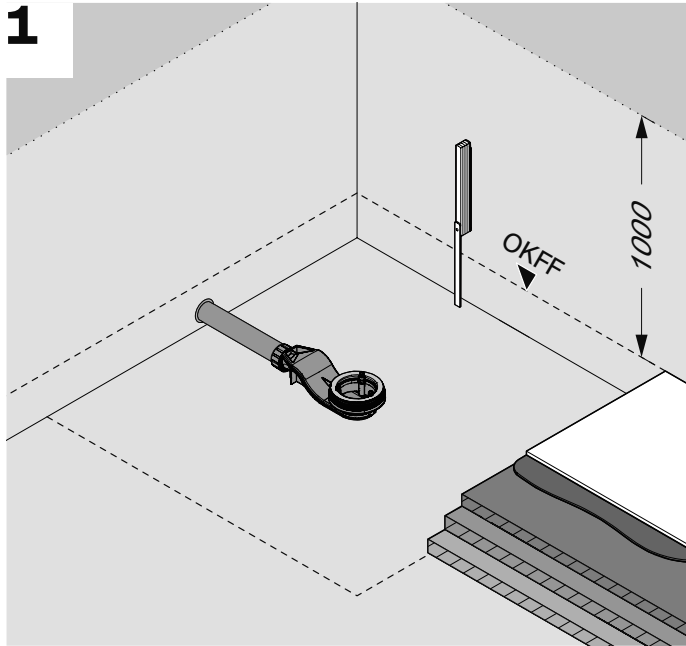

6x (B57-0421)  
8x (B57-0422)

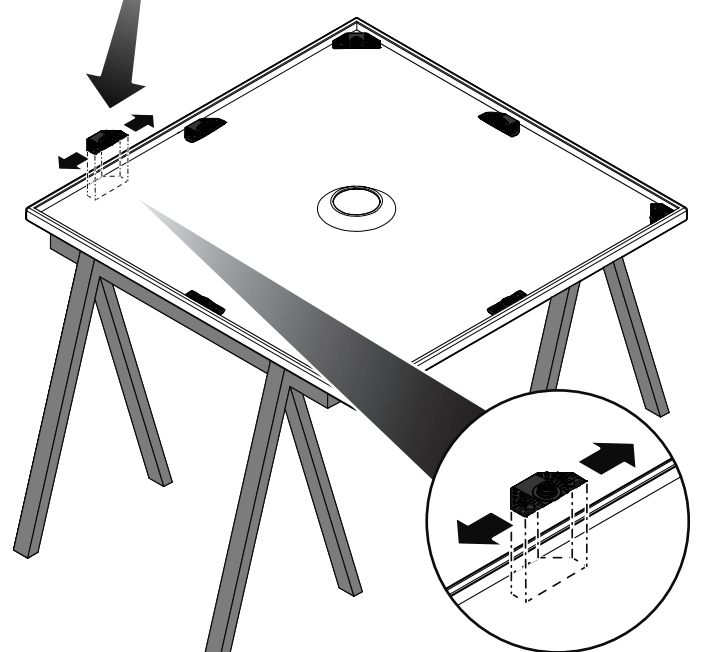
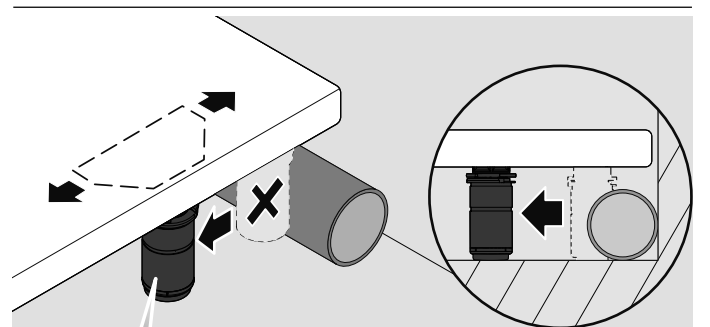
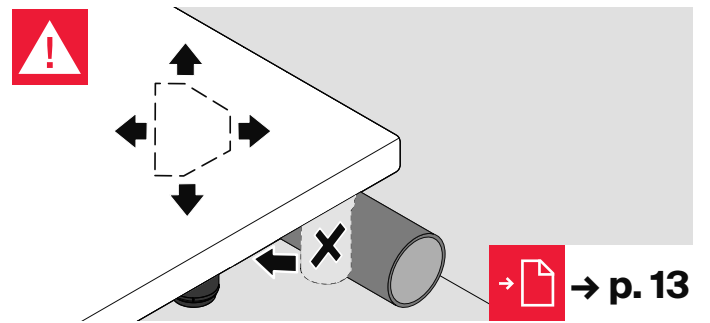
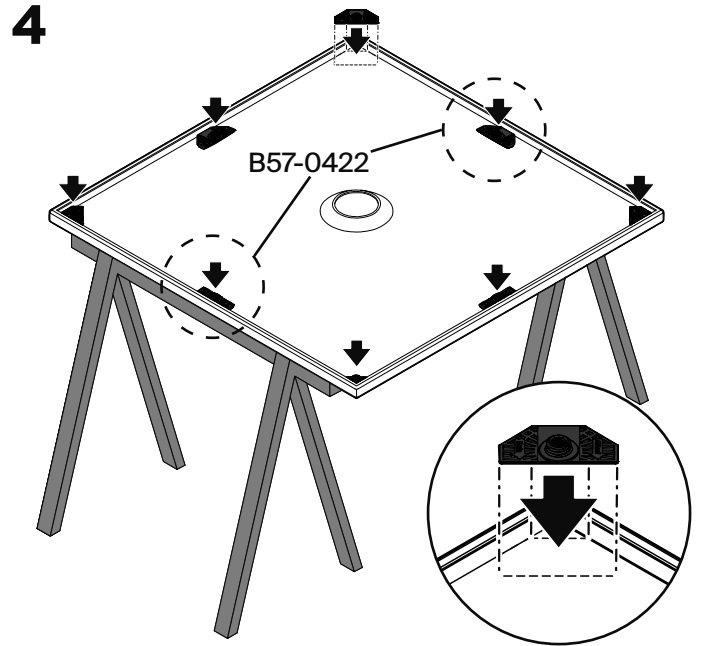

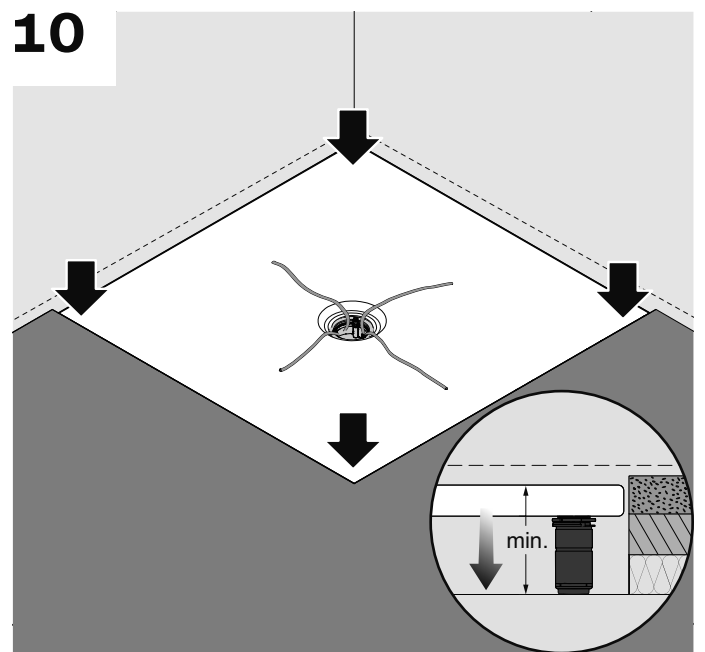
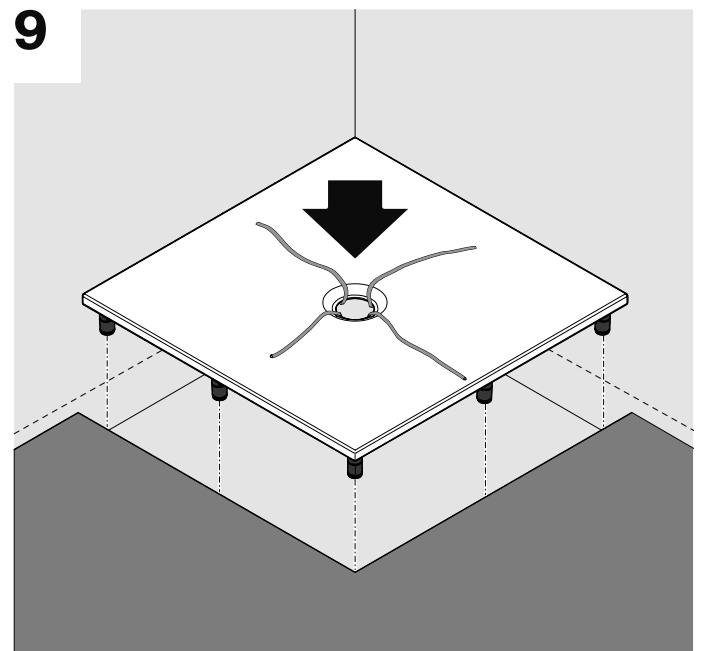
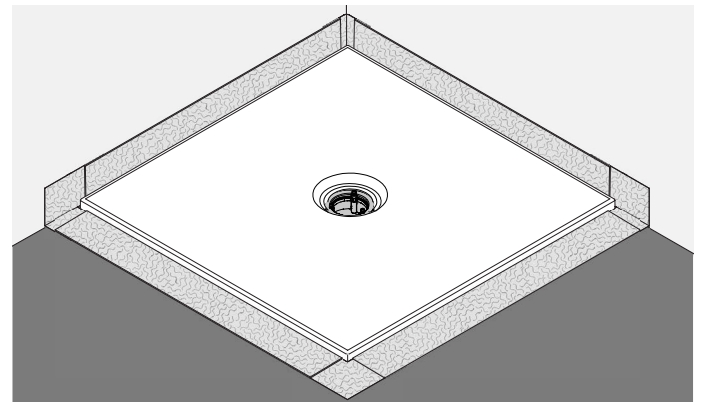
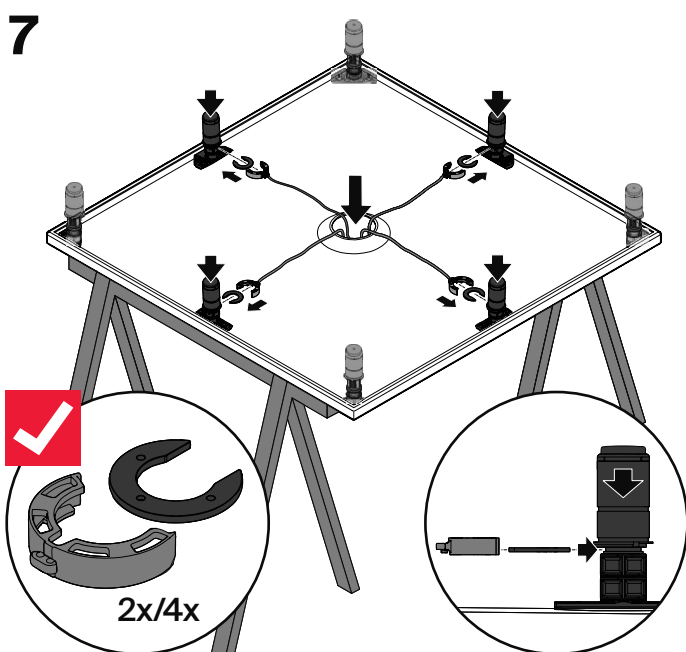
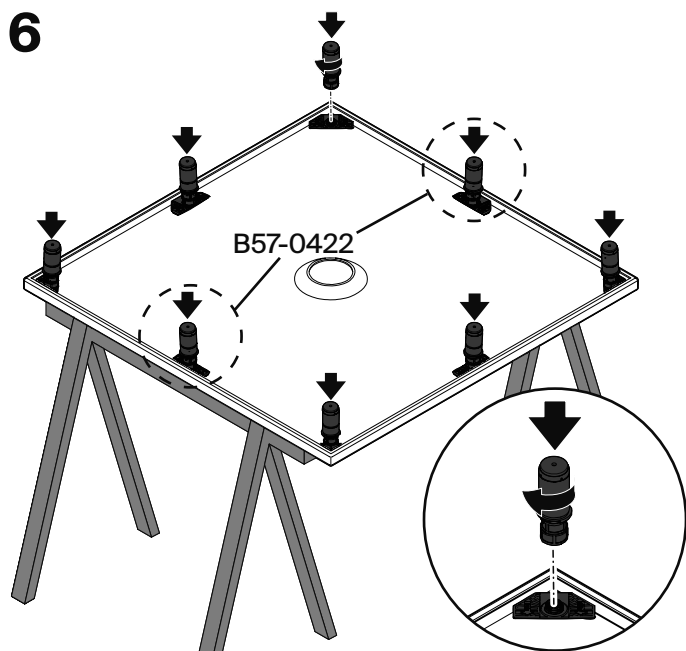
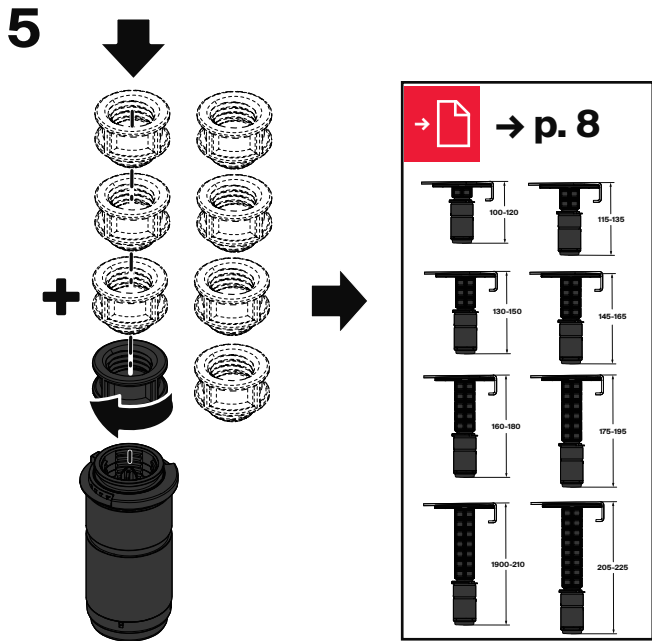

11

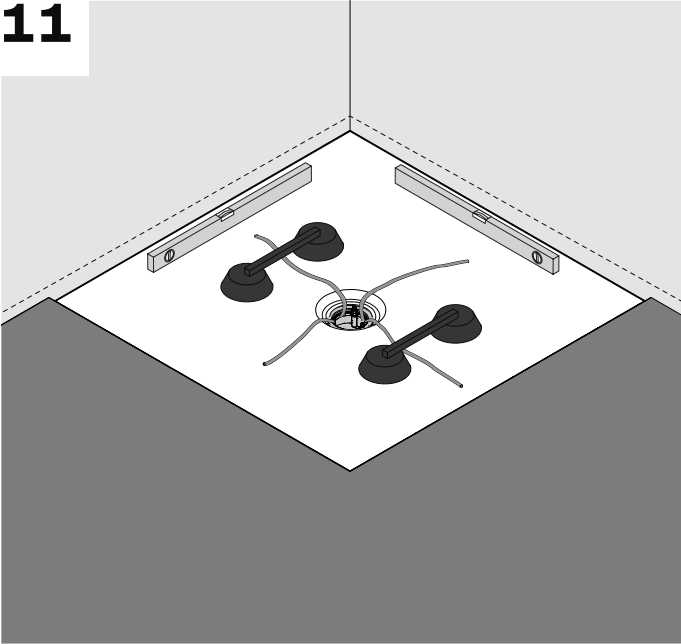

14

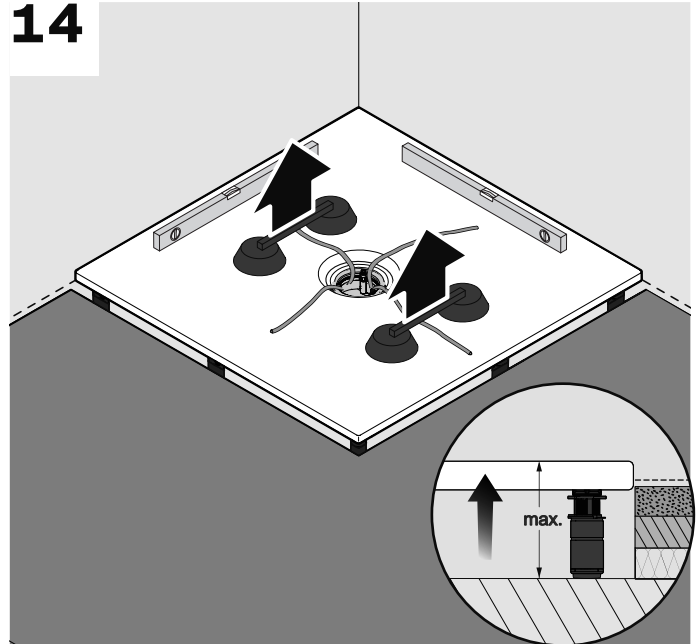

12

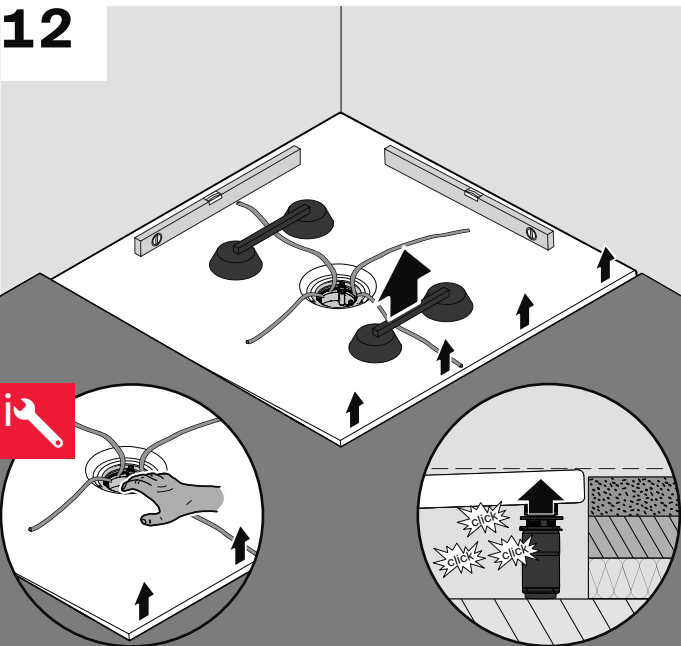

15

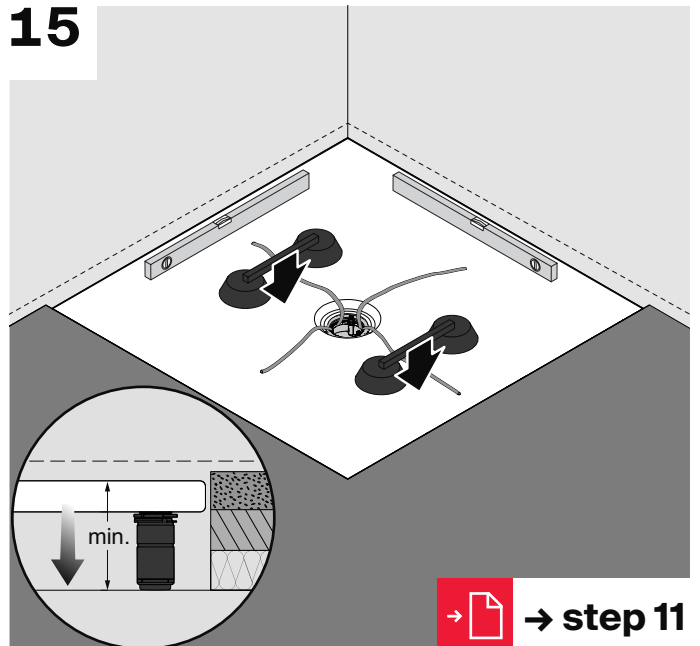

→ step 11

13

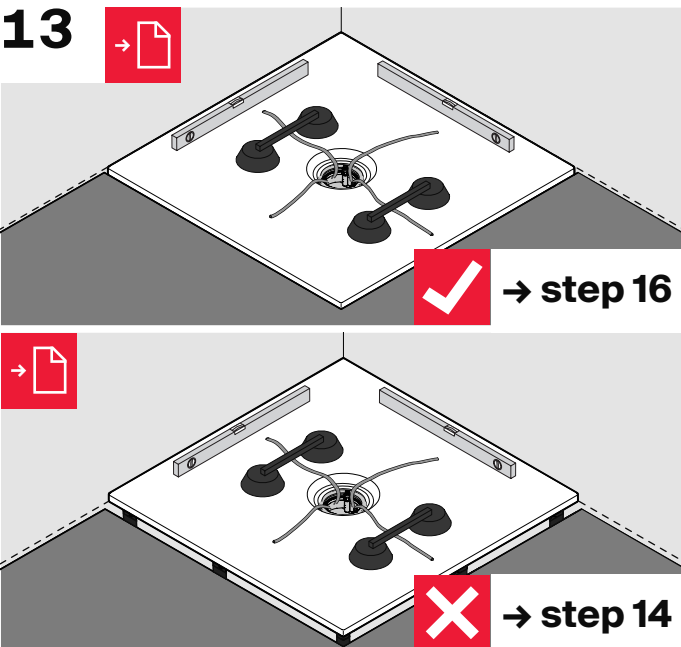

16

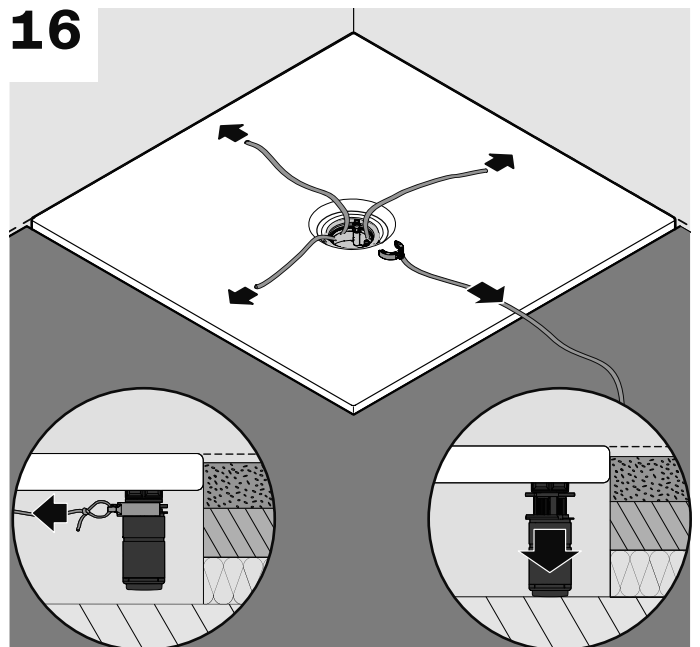

17

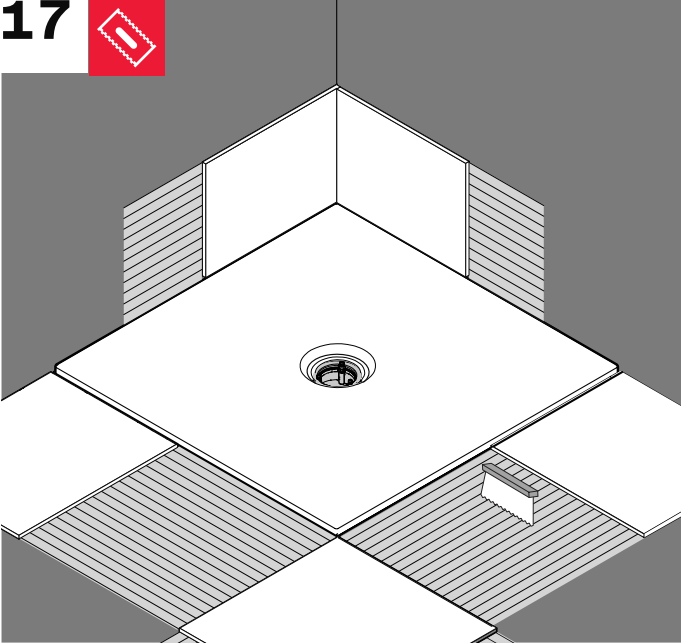

18

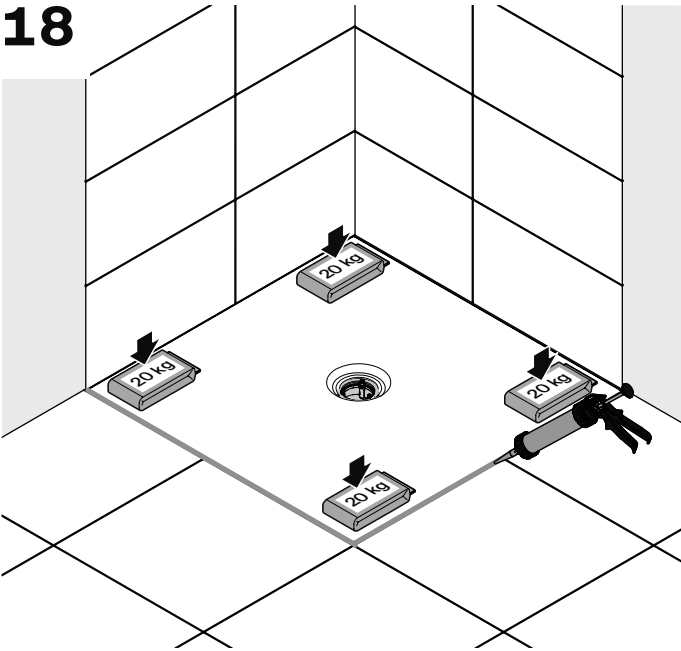

19

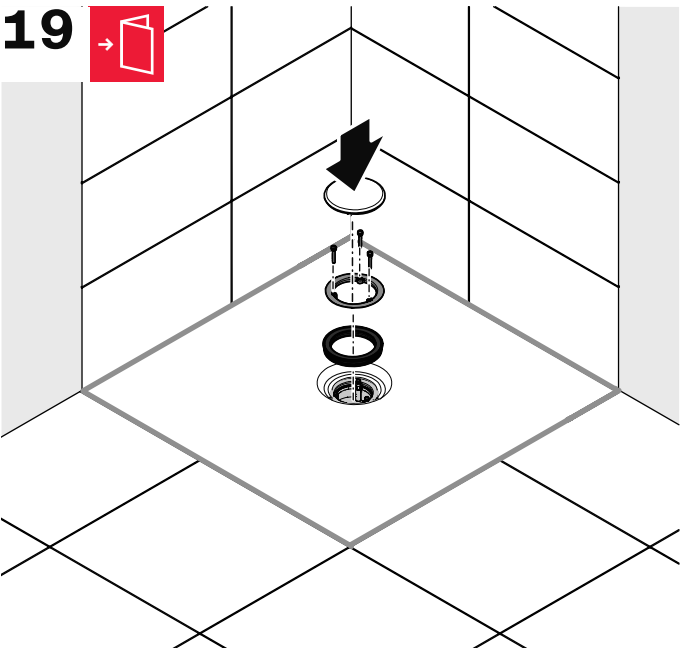

20

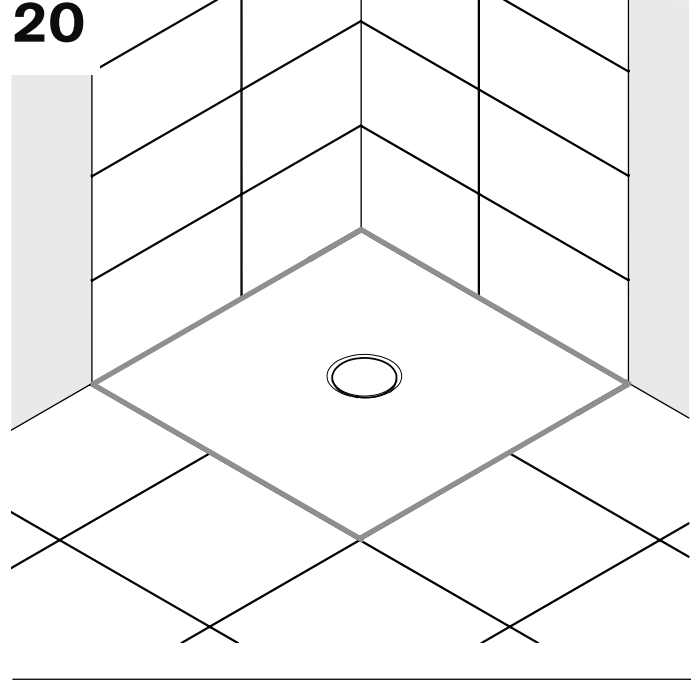



DE Platzierung eines Fußes unterhalb der Nutzfläche  
 EN Placement of a foot below the usable surface  
 FR Placement d'un pied en dessous de la surface utile  
 NL Plaatsing van een poot onder het bruikbare oppervlak

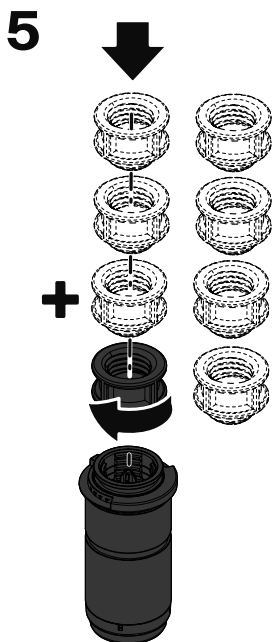
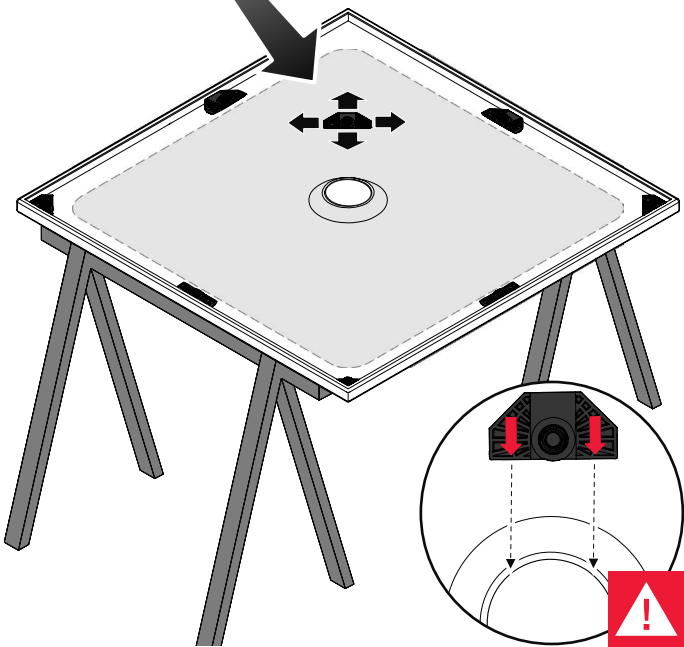
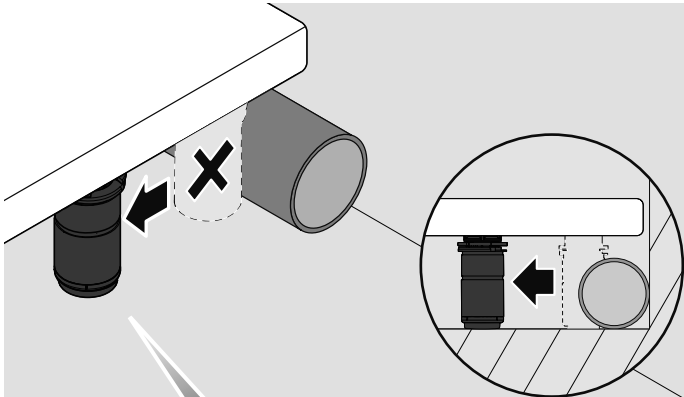

→ p. 8

	100-120		115-135
	130-150		145-165
	160-180		175-195
	190-210		205-225

**A**

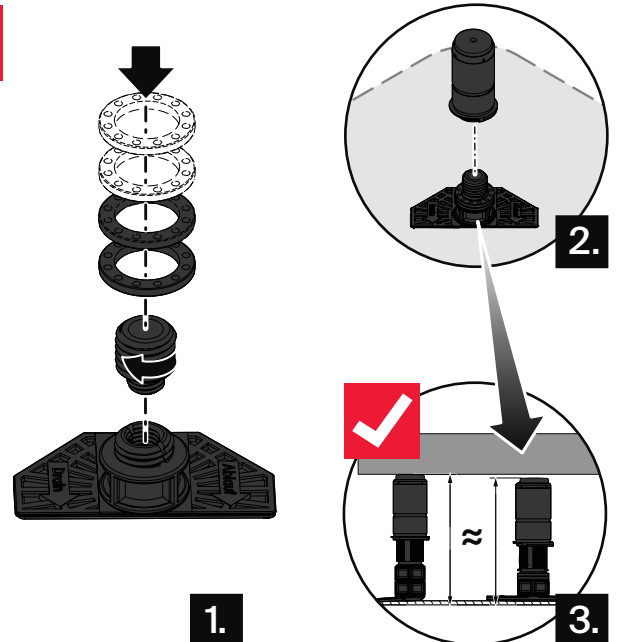
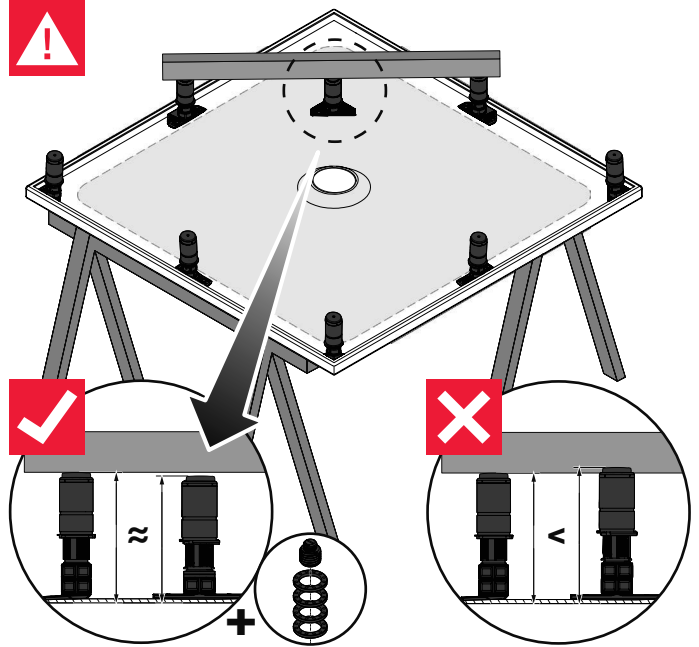
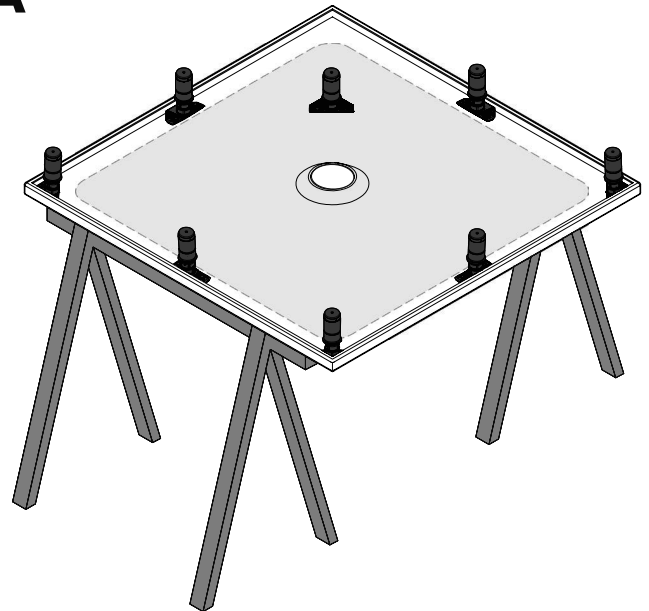



→ step 11

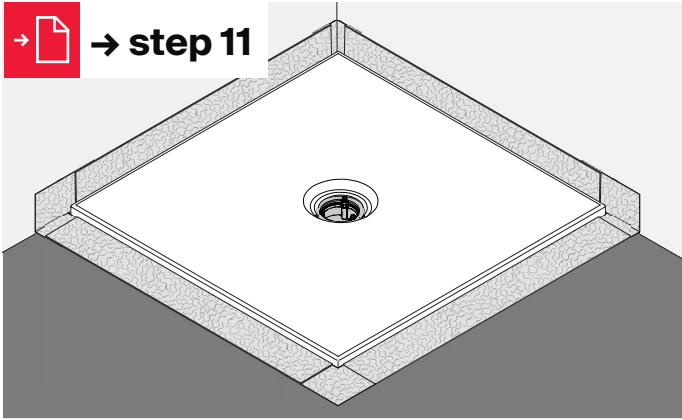

2x/4x

**B**

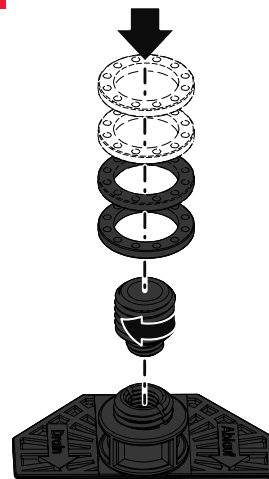
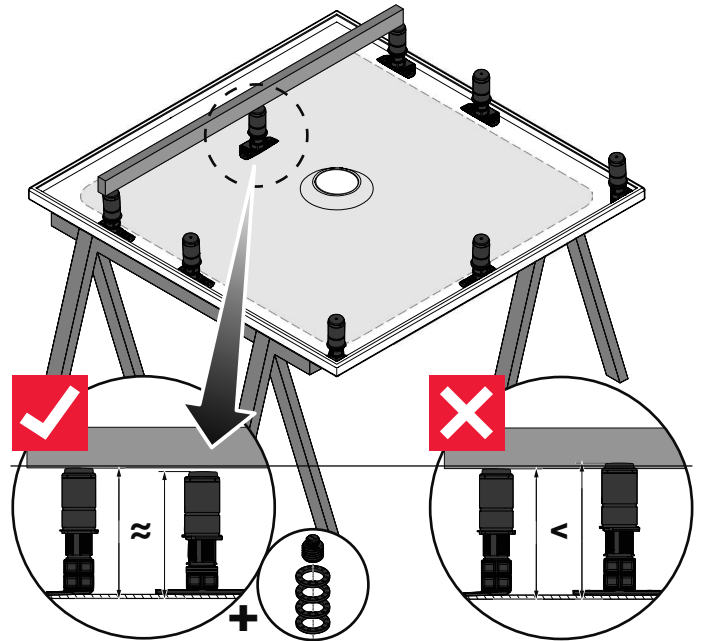
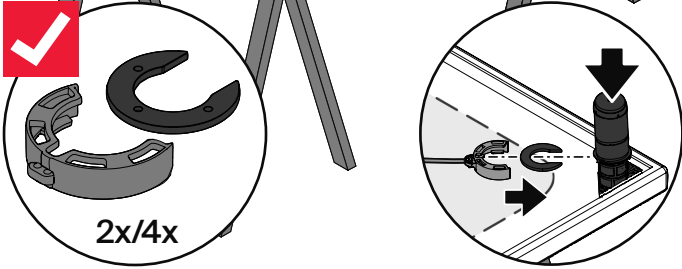
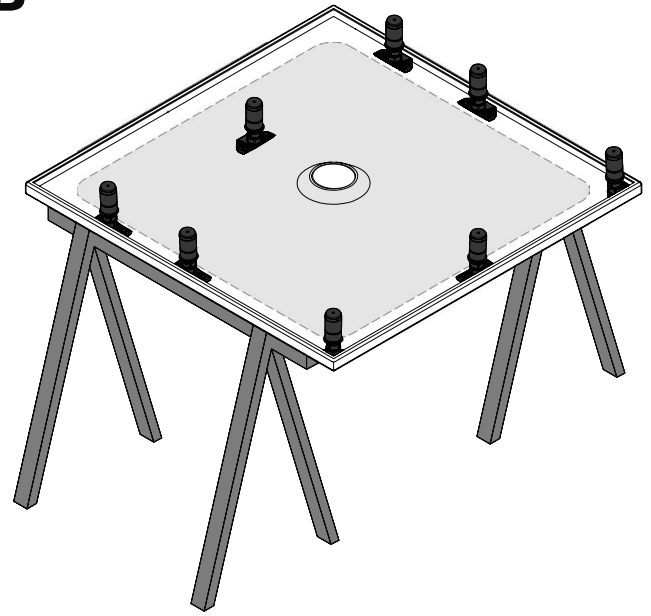

1.

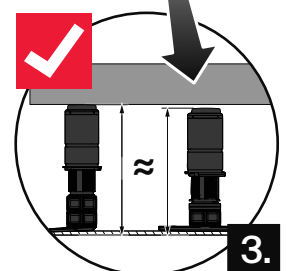
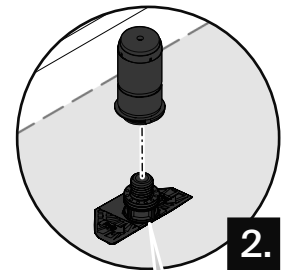

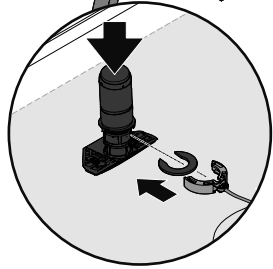
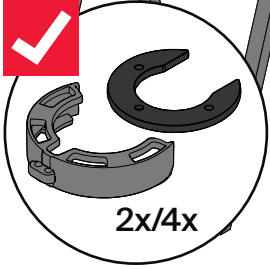
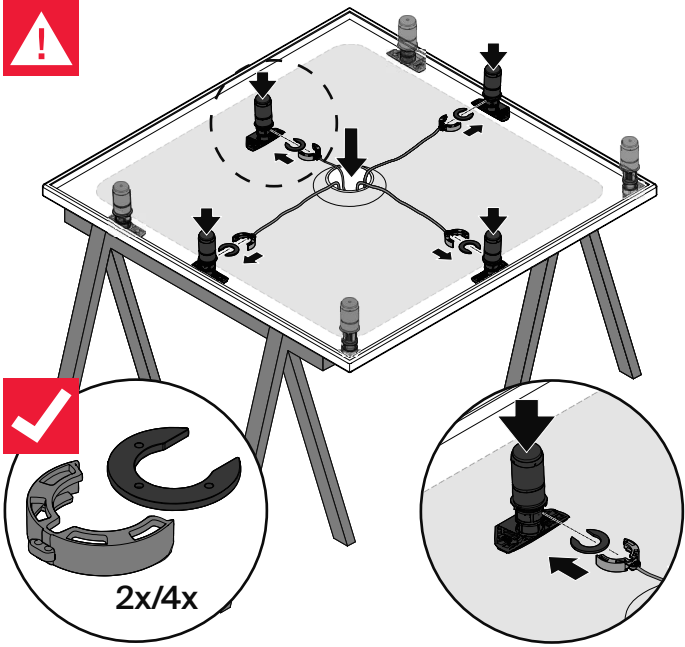

→ step 11

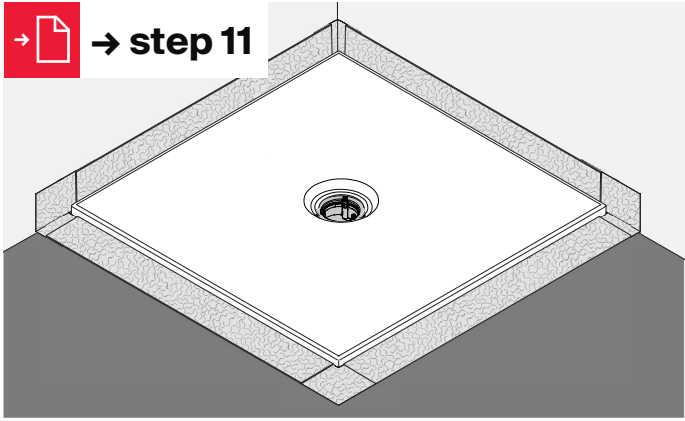



<https://qrco.de/bdlHXs>

Bette GmbH & Co. KG  
Heinrich-Bette-Straße 1  
33129 Delbrück  
Germany  
T +49 5250 511-0  
F +49 5250 511-130  
[info@bette.de](mailto:info@bette.de)

[www.my-bette.com](http://www.my-bette.com)

Rev. 2 / 11.2023 / Z0020130