

## Walraven Wall Mounting Set 62|H + Support

(H1925)

universal Mounting Set for outdoor appliances

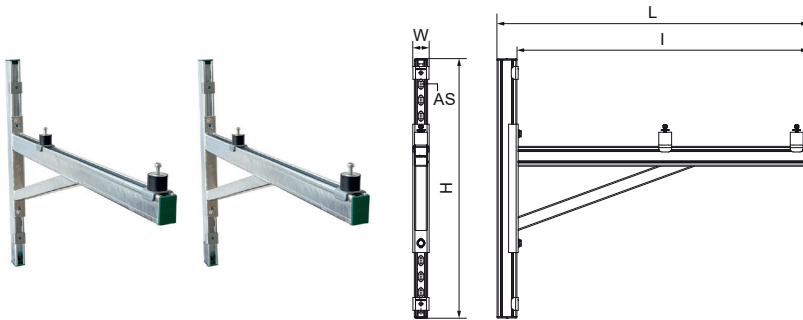

### Features & benefits

- suitable for indoor and outdoor use
- universal mounting brackets for fixing indoor and outdoor appliances to the wall
- designed for the most common standard heat pumps (for heat pump models with female thread, Walraven Wall Mounting ISO Kit 6901998 needs to be ordered separately - see assembly instruction)
- stepless adjustable in height and wall distance
- with anti-vibration mounts type Walraven VibraTek® SB-MM
- material: steel 1.0332
- material: vibration damper; rubber SBR + NR 55°+ -5 Shore A steel class 4.8
- surface treatment: hot dip galvanized (EN-ISO 1461)
- set consists of: - 2 Cantilever Arms type RapidStrut 62|H with welded support- 2 lengths of 500mm wall rail type RapidStrut 62|H- 4 vibration dampers with pre-assembled fasteners- 6 rail endcaps- fasteners to connect Cantilever Arms to the wall rail
- Max. allowed safeload per Set: 1.750 Newton (Total weight of the unit).

Product Number	Type	Length	Total Height	Total Width	Total Length	Material Thickness	Anchoring Slot	Heart To Heart Distance
<i>Reference letter</i>		<i>l</i>	<i>H</i>	<i>W</i>	<i>L</i>	<i>MT</i>	<i>AS</i>	<i>k</i>
<i>Unit description</i>		<i>mm</i>	<i>mm</i>	<i>mm</i>	<i>mm</i>	<i>mm</i>	<i>mm</i>	<i>mm</i>
6901990	62   H + Support	900	808	106	972	3.00	30x11	141