



Colour  
is our nature

## 8A DALI Full-Colour Dimmable LED Driver

### LINEARdrive

LINEARdrive gives you all the control you need for your low-voltage LED application. This constant voltage LED driver is DALI compatible and enables you to create the perfect shade of white or show sequence without an external controller. Symbiosis ensures the LED driver works seamlessly together with LED modules, controls and intelligent luminaire elements.

### Product offering



#### LINEARdrive 210/D

Part number (P/N)	LIN210D1
Product description	LINEARdrive DC, 200W, DALI, 1 control channel, constant voltage, 2x LED outputs, plastic long

### Features & benefits

Camera compatibility	HydraDrive technology is proven to work in TV studios and security camera environments
----------------------	--

### Programming tools

Programming interface	<a href="#">TOOLbox pro (TLU20504)</a>
Programming cable set	<a href="#">TOOLbox pro to LED driver, programming cable, 5pcs (TLC03051)</a>
Programming software	<a href="#">FluxTool</a>

### Warranty

Warranty period	<a href="#">General Terms and Conditions</a>
-----------------	--

**Order number configurator**

**LIN210D1**     
 Part Number      Dimming  
    Curve

Dimming curve      "LOG" for logarithmic (default)  
    "LIN" for linear

**Input characteristics**

Nominal input voltage DC      12 - 28V  
 Maximum input current      8A, irrespective of PSU voltage

**Output characteristics**

LED output load      8A maximum, irrespective of whether using one or both LED outputs  
 Maximum LED output power      200W  
 Number of LED outputs      2  
 LED output voltage      12 - 28V  
 Auxiliary output voltage      equal to input voltage  
 Auxiliary output current      180mA @ 12V, 90mA @ 24V  
 Maximum auxiliary output power      2W  
 Circuit protection      To prevent excessive output current from damaging the LED driver, it is highly recommended to use circuit protection appropriate for your application's nominal and inrush current requirements in combination with an OVP, OVC short circuit protected AC/DC adapter.

### Control characteristics

Control channels	1
Control protocol	DALI version-1, Device Type 6
Dimming range	100% - 0.1%
Dimming curve options	Logarithmic (default) Linear
Dimming method	HydraDrive

### Dimming curves

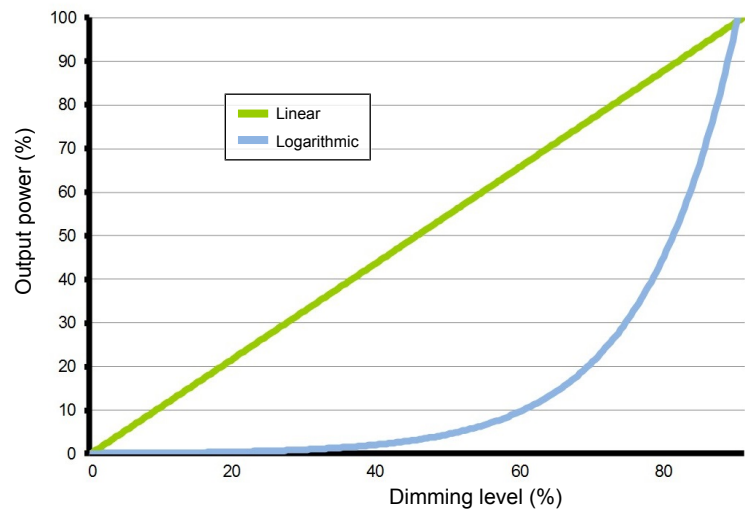

### Environmental conditions

Operating ambient temperature (Ta) range	-20 °C to +50 °C
Maximum operating case temperature (Tc max)	65 °C

**LED driver mechanical details**

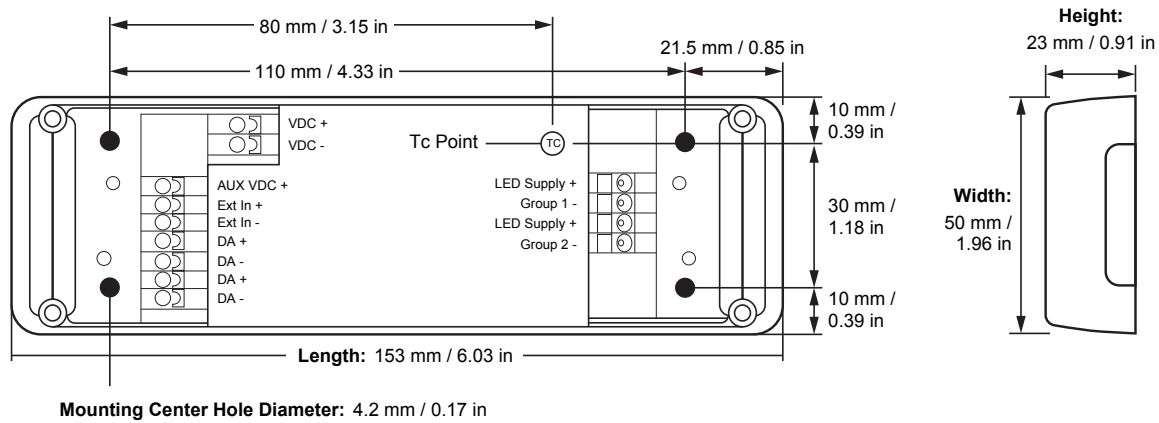

Weight 120 g

3D mechanical files for this product are available on the eldoLED website.

**Packaging**

Products per box 12 pcs

**Connector layout**



**Wiring specifications**

Wire core cross section 0.2 - 1.5 mm<sup>2</sup>  
AWG 24 – 16

Wire strip length 9.0 mm / 0.35 inch

**Standards and compliance**

UL, recognized component	UL 1310 UL 8750
ENEC safety	EN 61347-1 EN 61347-2-13 (Emergency lighting)
Conducted emissions	EN 55015
Radiated emissions	EN 55015
ECodesign 2019/2020: Controlgear + luminaire	Flicker for LED: Pst LM ≤ 1.0 at full-load Stroboscopic effect for LED: SVM ≤ 0.4 at full load
DALI	EN 62386-101/102/207
Restriction of hazardous substances	RoHS3 (Directives 2011/65/EU-2015/863/EU)

**Certifications**



---

## Safety

---



Risk of electrical shock. May result in serious injury or death. Disconnect power before servicing or installing.

---



The LED driver may only be connected and installed by a qualified electrician. All applicable regulations, legislation, and building codes must be observed. Incorrect installation of the LED driver can cause irreparable damage to the LED driver and the connected LEDs.

Pay attention when connecting the LEDs: polarity reversal results in no light output and often damages the LEDs.

---



LED drivers are designed and intended to operate LED loads only. Powering non-LED loads may push the LED driver outside its specified design limits and is, therefore, not covered by any warranty.

---



eldoLED products are designed to meet the performance specifications as outlined at certain operating conditions in the data sheet. It is the responsibility of the fixture manufacturer to test and validate the design and operation of the system under expected and potential use cases, including faults.

---



Please observe voltage drop over long cable lengths. Longer cable lengths increase EMI susceptibility.

---



Product renderings and dimensional drawings are generic for the housing type. Product label, connector type and quantity may vary.

---

---

### Europe, Rest of World

eldoLED B.V.  
Science Park Eindhoven 5125  
5692 ED Son  
The Netherlands

E: [info@eldoled.com](mailto:info@eldoled.com)  
W: [www.eldoled.com](http://www.eldoled.com)

---

### North America

eldoLED America  
One Lithonia Way  
Conyers, GA 30012  
USA

E: [info@eldoled.com](mailto:info@eldoled.com)  
W: [www.eldoled.com](http://www.eldoled.com)

---