

4CH RDM DMX512 Decoder

Article number: 214-185

Important: Read All Instructions Prior to Installation

Function introduction

2 groups DMX512 signal input & output

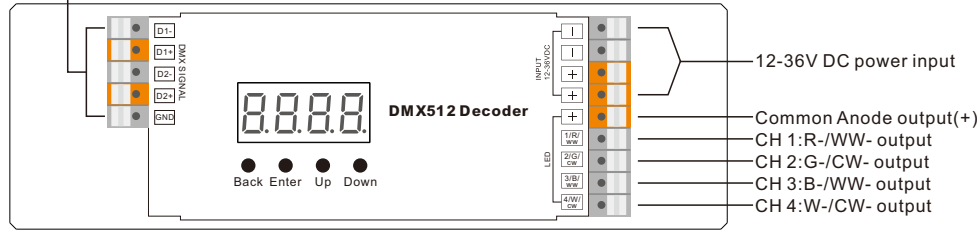

Product Data

No.	Input Voltage	Output Current	Output Power	Remarks	Size(LxWxH)
1	12-36VDC	4x5A	4x(60-180)W	Constant voltage	170x53.4x28mm

- DMX decoder & Master mode
- RDM function
- Digital display to show data directly, easily to set and show DMX address.
- Total 4 PWM output channels, common anode. DMX channel quantity from 1CH~4CH settable
- PWM output resolution ratio 8bit , 16bit settable.
- Output PWM frequency from 500HZ ~ 35K HZ settable.
- Output dimming curve gamma value from 0.1 ~ 9.9 settable.
- Decoding mode settable.
- IP20

Safety & Warnings

- DO NOT install with power applied to device.
- DO NOT expose the device to moisture.

Operation

Before you do other settings, please set the device to be Master or Decoder mode.

run1 = DMX Decoder mode, **run2** = DMX Master mode(stand alone).

Keep on clicking Down button, to get run1 or run2, then click Enter, then click Down button to choose 1 or 2, then click Back button.

After choose run1 or run2, please power off and power on again the device.

I. For run2 DMX Master mode: After power on the device, if keep on clicking Up button, you will find below menu on display:

0000 Means brightness for each output PWM channel. First 1 means PWM output channel 1 and it is selectable from 1 to 4 by clicking "UP" or "Down" button. Second 01 means brightness level, click "Enter" button, the display flashes, then click "UP" or "Down" button to select from 00-99-FL, which means 0%-99%-100% brightness, then click "Back" button to confirm.

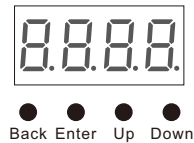

P.XXX Means programs , total 1~31 programs.

B- XX Means RGB running effect's brightness, total 1~8 levels brightness

SP-X Means effect play speed. total 1~9 levels speed.

P-XX means RGB color changing modes, total 31 programs:

- 00- RGB off
- 01- Static red
- 02- Static green
- 03- Static blue
- 04- Static yellow (50% red+50% green)
- 05- Static orange (75% red+25% green)
- 06- Static cyan (50% green+50% blue)
- 07- Static purple (50% blue+50% red)
- 08- Static white (100% red+100% green+100% blue)
- 09- Any two colors of RGB mix fade, changing diagram as follow:

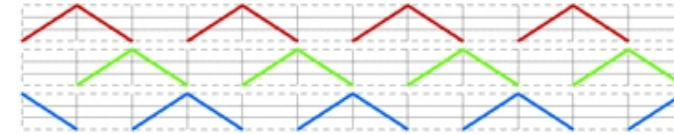

10- RGB colors mix fade, changing diagram as follow:

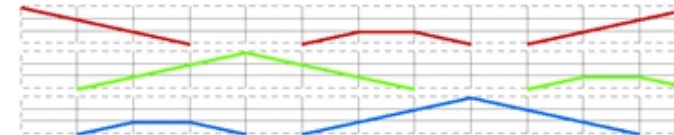

11- RGB FADE OUT & FADE IN, changing diagram as follow:



12- RGB jump changing, changing diagram as follow:



13- RGB FADE IN, changing diagram as follow:



14- RGB FADE OUT, changing diagram as follow:



- 15- RGB 3 colors strobe
- 16- White color strobe (100% red+100% green+100% blue)
- 17- 7 colors FADE OUT & FADE IN (red, orange, yellow, green, cyan, blue, purple FADE OUT & FADE IN)
- 18- 7 colors jump changing (red, orange, yellow, green, cyan, blue, purple jump changing)
- 19- 7 colors strobe (red, orange, yellow, green, cyan, blue, purple strobe)
- 20- Red-white (100% red+100% green+100% blue) circle gradual changing
- 21- Green-white (100% red+100% green+100% blue) circle gradual changing
- 22- Blue-white (100% red+100% green+100% blue) circle gradual changing
- 23- Red-orange circle gradual changing
- 24- Red-purple circle gradual changing
- 25- Green-yellow circle gradual changing
- 26- Green-cyan circle gradual changing
- 27- Blue-purple circle gradual changing
- 28- Blue-cyan circle gradual changing
- 29- Red-yellow-green circle gradual changing
- 30- Red-purple-blue circle gradual changing
- 31- Green-cyan-blue circle gradual changing

run2 Means the device at run2 mode (DMX master, standalone).

To make a setting is like this: Up/Down--- Enter--- Up/Down---Back

II. For run1 DMX decoder mode: After power on the decoder, if keep on clicking Up button, you will find below menu on display:

DMX signal indicator ● :: When DMX signal input is detected, the indicator on the display following after **A** turns on red **A.XXX**.

A.XXX Means DMX address. factory defaults setting is 001.

CHXX Means DMX channels quantity.

BEXX Means Bit (8bit or 16bit). factory defaults setting is 16bit

PEXX Means output PWM frequency. factory defaults setting is 1K HZ

GAXX Means output dimming curve gamma value, factory defaults setting is ga 1.5

DPXX Means Decoding mode, factory defaults setting is dp1.1

run1 Means the device at run1 mode (DMX decoder).

DMX address is 001, CH01

DMX Console Slider number / DMX channel	dp1.1	dp2.1
1	for all output dimming	for all output dimming
2	No use	for all output fine dimming

DMX address is 001, CH02

DMX Console Slider number / DMX channel	dp1.1	dp2.1	dp3.2
1	for output 1&3 dimming	for output 1&3 dimming	for output 1&3 dimming
2	for output 2,4 dimming	for output 1&3 fine dimming	for output 2,4 dimming
3		for output 2,4 dimming	for all output dimming
4		for output 2,4 fine dimming	

DMX address is 001, CH03

DMX Console Slider number / DMX channel	dp1.1	dp2.1	dp4.3	dp5.3
1	for output 1 dimming	for output 1 dimming	for output 1 dimming	for output 1 dimming
2	for output 2 dimming	for output 1 fine dimming	for output 2 dimming	for output 2 dimming
3	for output 3,4 dimming	for output 2 dimming	for output 3,4 dimming	for output 3,4 dimming
4		for output 2 fine dimming	for all output master dimming	for all output master dimming
5		for output 3,4 dimming		strobe effects
6		for output 3,4 fine dimming		

By holding button Back + Enter together at the same time over 5 seconds until the display go off, it will restore default settings .

1. DMX address setting:

select menu **A.XXX**, click button "Enter", display flashes, then click or hold button "Up" / "Down" to set DMX address (click is slow, hold is fast.), then click button "Back" to confirm.

2. DMX channel quantity setting:

Select menu **CHXX**, click button "Enter", display flashes, then click button "Up" / "Down" to set DMX channel quantity, then click button "Back" to confirm.

For example the DMX address is already set 001.

CH01=1 DMX address for all the output channels, which are all address 001.

CH02=2 DMX addresses, output 1&3 is address 001, output 2,4 is address 002

CH03=3 DMX addresses, output 1, 2 is address 001,002, output 3,4 is address 003

CH04=4 DMX addresses, output 1,2,3,4 is address 001,002,003,004

3. PWM output resolution Bit setting:

select menu **BEXX**, click button "Enter", display flashes, then click button "Up" / "Down" to choose 08 or 16 bit, then click button "Back" to confirm.

4. output PWM frequency setting:

select menu **PEXX**, click button "Enter", display flashes, then click button "Up" / "Down" to choose 00~35, then click button "Back" to confirm. 00=500HZ, 01=1kHz, 02=2kHz.....25=25kHz, 35=35kHz.

5. output dimming curve gamma value setting:

select menu **GAXX**, click button "Enter", display flashes, then click or hold button "Up" / "Down" to choose 0.1~9.9, then click button "Back" to confirm.

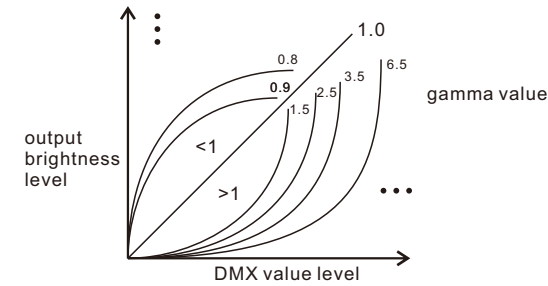

6. DMX decoding mode setting:

Select menu **DPXX**, click button "Enter", display flashes, then click or hold button "Up" / "Down" to choose the decoding mode, then click button "Back" to confirm. "dPxx" means the DMX address quantity used for control of corresponding PWM output channel quantity. 1st "x" is DMX address quantity, 2nd "x" is PWM channel quantity.

Fine dimming: the fine dimming effect can only be visible when the dimming curve gamma value is set ≤ 1.4, and the lower the value is, the more visible the fine dimming effect will be.

DMX address is 001, CH04

DMX Console Slider number / DMX channel	dp1.1	dp2.1	dp5.4	dp6.4
1	for output 1 dimming	for output 1 dimming	for output 1 dimming	for output 1 dimming
2	for output 2 dimming	for output 1 fine dimming	for output 2 dimming	for output 2 dimming
3	for output 3 dimming	for output 2 dimming	for output 3 dimming	for output 3 dimming
4	for output 4 dimming	for output 2 fine dimming	for output 4 dimming	for output 4 dimming
5		for output 3 dimming	for all output master dimming	for all output master dimming
6		for output 3 fine dimming		strobe effects
7		for output 4 dimming		
8		for output 4 fine dimming		

The data definitions for strobe channel are as follows:

```
{0, 7},//undefined
{8, 65},//slow strobe-->fast strobe
{66, 71},//undefined
{72, 127},//slow push fast close
{128, 133},//undefined
{134, 189},//slow close fast push
{190, 195},//undefined
{196, 250},//random strobe
{251, 255},//undefined
```

The supported RDM PIDs are as follows:

```
DISC_UNIQUE_BRANCH
DISC_MUTE
DISC_UN_MUTE
DEVICE_INFO
DMX_START_ADDRESS
IDENTIFY_DEVICE
SOFTWARE_VERSION_LABEL
DMX_PERSONALITY
DMX_PERSONALITY_DESCRIPTION
SLOT_INFO
SLOT_DESCRIPTION
MANUFACTURER_LABEL
SUPPORTED_PARAMETERS
MODULATION_FREQUENCY
MODULATION_FREQUENCY_DESCRIPTION
CURVE
CURVE_DESCRIPTION
```

Restore to Factory Default Setting

Press and hold down both "Back" and "Enter" keys until the digital display turns off, then release the keys, system will reset and the digital display will turn on again, all settings will be restored to factory default.

Default settings are as follows:

```
DMX Address Code: a001
DMX Address Quantity: SW1=0: ch04, SW1=1: ch03
PWM Resolution Mode: bt16
PWM Frequency: pf01
Gamma: ga1.5
Decoding Mode: dp1.1
```

Wiring Diagram

1.Work as Master mode

1) When total load of each receiver is not over 10A

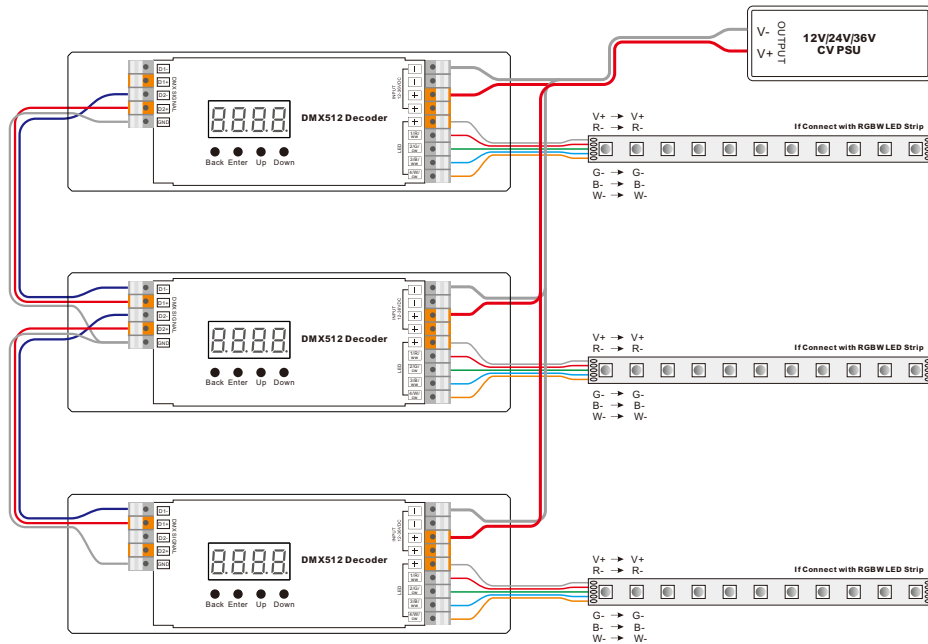

2) When total load of each receiver is over 10A

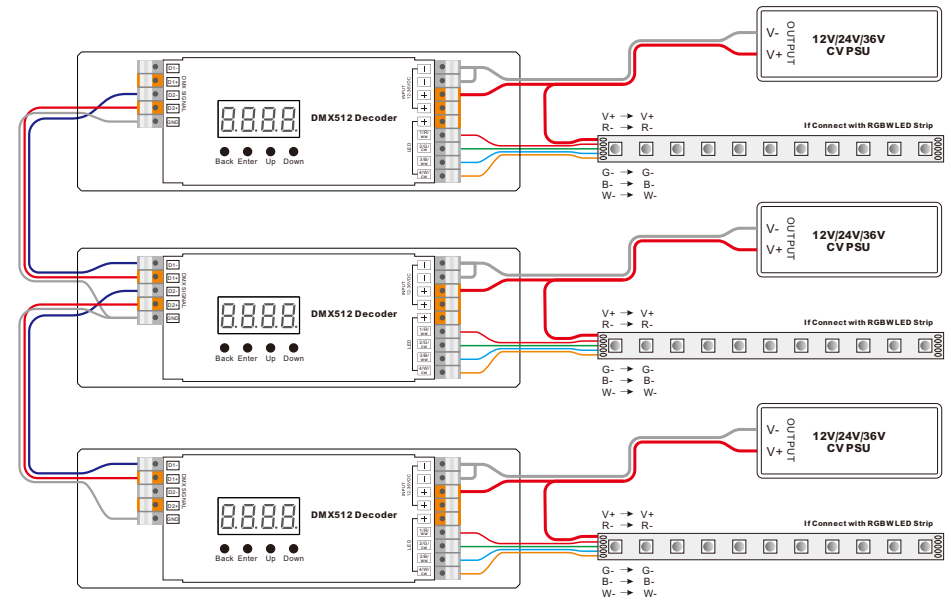

2.Work as Decoder mode

1) When total load of each receiver is not over 10A

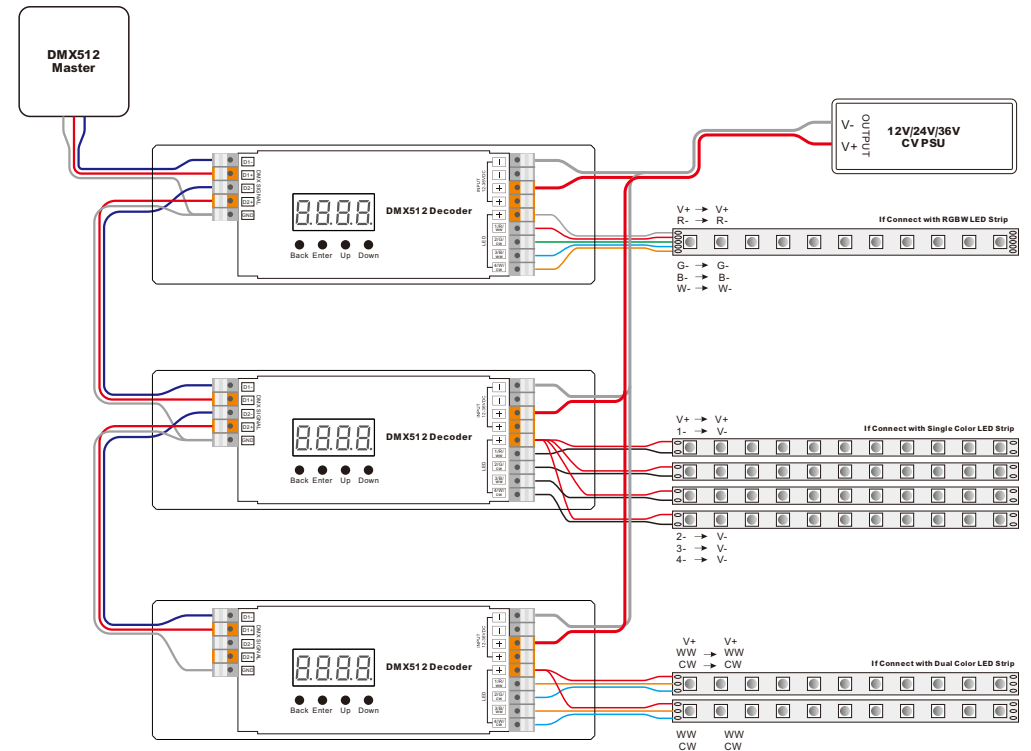

2) When total load of each receiver is over 10A

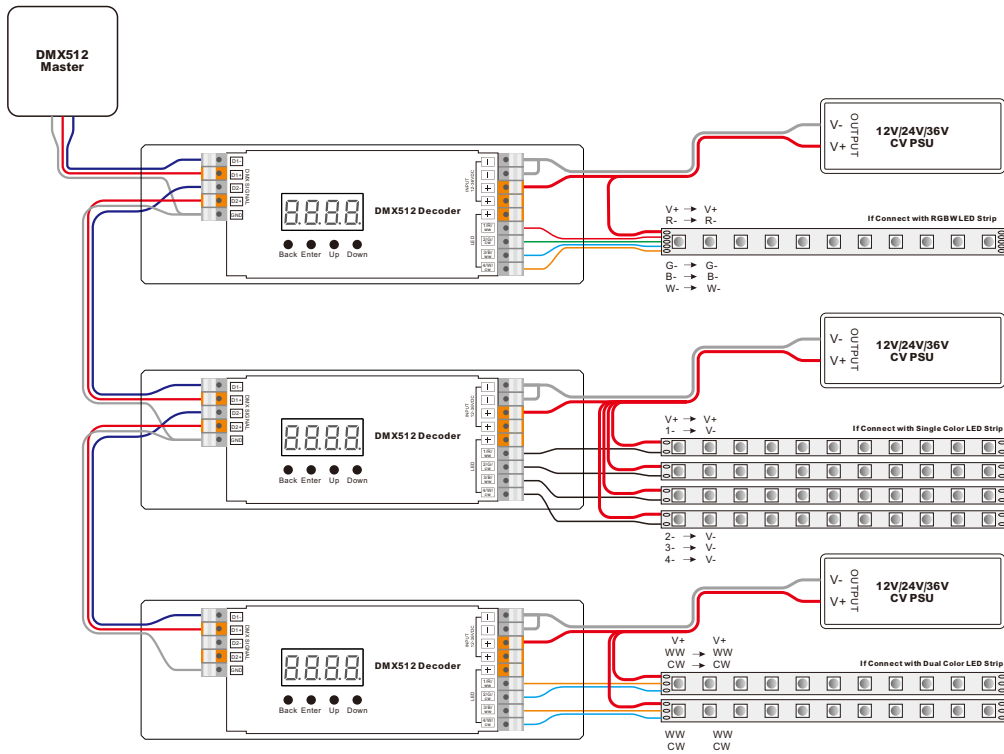

RDM Discovery Indication:

When using RDM to discover the device, the digital display will flash and the connected lights will also flash at the same frequency to indicate. Once the display stops flashing, the connected light also stops flashing.

Product Dimension

