

Data Sheet | Item Number: 891-8992/206-207

pre-assembled connecting cable; Eca; Plug/open-ended; 2-pole; Cod. B; Control cable 2 x 1.5 mm²; 2 m; 1,50 mm²; pink

<https://www.wago.com/891-8992/206-207>

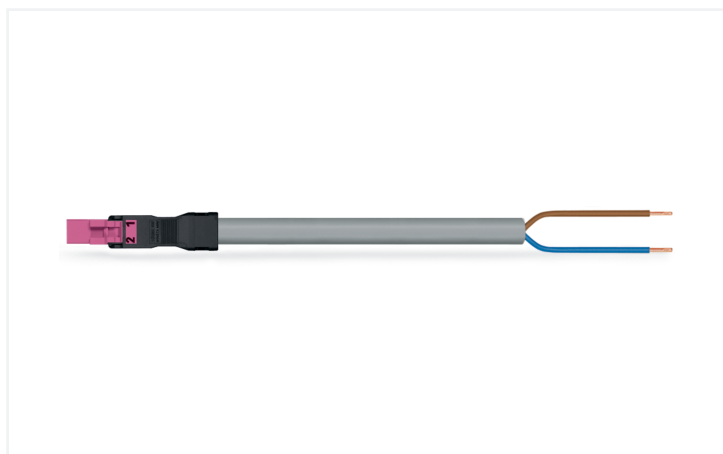

Color: ■ pink

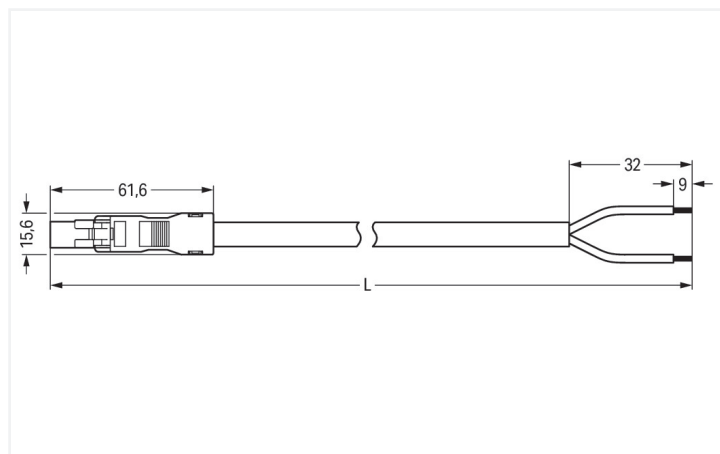

Dimensions in mm

Cable assembly WINSTA® MINI with protection against mismatching

The WINSTA® MINI cable assembly 2-pole supports rapid, correct installation. On PCBs, in control cabinets or for connecting lights – pluggable installation connectors from WAGO allow you to make connections according to various requirements in no time flat. For greater protection in electrical installations, the pluggable installation connector is equipped with mechanical protection against mismatching. Pluggable installation connectors with B coding from the WINSTA® MINI line are available in pink, light green, or gray, allowing you to distinguish different circuits, for example for light, pumps or, sun blinds. Your own pole marking is possible as well. WINSTA® MINI follows the trend towards miniaturisation. Our smallest pluggable connection system is especially suitable for lights, for example, since as a result of LED technology; due to complex systems, these offer less and less space for the connection technology. This product meets all the mandatory safety requirements of fire class E; therefore it can be used in domains where fire safety is relevant.

Fast, secure pluggable connections – cable assemblies from WAGO

A plug and a free end are available. The WINSTA® Pluggable Connection System is ideally tailored to the strict requirements of building installation. It makes electrical installation pluggable, and consequently faster, more reliable, and error-free. Use of this pre-assembled system decreases time spent on assembly and errors during installation at the construction site. Take advantage of the pluggable version of our maintenance-free spring pressure connection technology too! Plan your installation with with fire class E from WAGO.

- effective protection against mismatching
- consistent IP40 protection
- with B coding for controllers, for example lighting fixtures and sun blinds
- ready to install and use immediately
- quick replacement of defective units during ongoing operation

Notes

Note

Cables with a different fire class can be found in the eShop.

Variants:

Other pole markings

Other versions (or variants) can be requested from WAGO Sales or configured at <https://configurator.wago.com/>.

Electrical data

Ratings per	IEC/EN 60664-1		
Overvoltage category	III	III	II
Pollution degree	3	2	2
Nominal voltage	250 V	-	-
Rated impulse withstand voltage	4 kV	-	-
Rated current	16 A	-	-

General information

Note on contact resistance	approx. 1 mΩ of contact resistance approx. 0.25 mΩ contact transition plug/ socket
----------------------------	--

Connection Data

Total number of potentials	2
Conductor preparation	ultrasonically tip-bonded

Connection 1

Strip length	9 mm / 0.35 inches
Pole number	2
Wire cross-section	1.5 mm ²
Strip length (outer insulation)	32 mm
Connection type	Plug - free end

Physical data

Pin spacing	4.4 mm / 0.173 inches
Width	15.6 mm / 0.614 inches
Height	13.2 mm / 0.52 inches
Total length	2 m

Mechanical data

Use	Control technology
Coding	B
Variable coding	No
Marking	1 2
Potential marking	1 2
Mating force of a plug-in connection	approx. 20 ... 70 N (depending on pole number)
Retention force of a plug-in connection	when locked: > 80N
Unmating force of a plug-in connection	when unlocked: approx. 20 ... 70 N (depending on pole number)
Number of mating cycles	200, without resistive load
Connection type	Plug - free end
Type of pre-assembled cable	Connecting cable
Cable type	Control line 2x1.5
Protection type	IP20; IP40 when mated

Plug-in connection

Mismating protection	Yes
Note on mismating protection	All <i>WINSTA</i> ® components are 100% protected against mismating when: a.) plugging different numbers of poles b.) plugging while rotated 180 c.) plugging while laterally staggered d.) plugging one pole
Locking lever	Can be retrofitted
Locking of plug-in connection	Locking lever
Note on locking system	All connectors for mounted installations (snap-in versions for lighting fixtures or devices, all types of PCB and distribution connectors) are factory-equipped with locking levers to ensure plugs and sockets are securely locked. Additional locking levers are only required for flying leads (plug/socket).

Material data

Note (material data)	Information on material specifications can be found here
Color	pink
Insulation material (main housing)	Polyamide (PA66)
Fire class per EN 50575	E _{ca}
Contact material	Copper or copper alloy; surface-treated
Contact Plating	Tin
Fire load	0.15 MJ
Connector color	pink
Strain relief color	black
Sheathed cable color	gray
Printing color of sheathed cable	black
Halogen-free	No
Silicon-free	Yes
Sheath material	PVC
Rubber cable	No
Weight	134.5 g
Copper weight of the raw cable	0.029 kg/m

Environmental requirements

Processing temperature	-5 ... +40 °C
Continuous operating temperature	-35 ... +85 °C
Note on continuous operating temperature	Cable for temperatures ≤ 70 °C (including halogen-free) Insulating parts for temperatures ≤ 105 °C

Commercial data

PU (SPU)	1 pcs
Packaging type	unpacked
Country of origin	PL
GTIN	4055143511568
Customs tariff number	85444290900

Product Classification

UNSPSC	26121629
eCl@ss 10.0	27-44-06-04
eCl@ss 9.0	27-44-06-04
ETIM 9.0	EC002587
ETIM 10.0	EC002587
ECCN	NO US CLASSIFICATION

Environmental Product Compliance

RoHS Compliance Status	Compliant, No Exemption
------------------------	-------------------------

Downloads

Environmental Product Compliance

Compliance Search

Environmental Product Compliance
891-8992/206-207



Documentation

Bid Text

891-8992/206-207	19.02.2019	xml 3.03 KB	
891-8992/206-207	02.12.2014	doc 25.00 KB	

CAD/CAE-Data

CAE data

EPLAN Data Portal
891-8992/206-207



1 Compatible Products

1.1 Required Accessories

1.1.1 Locking system

1.1.1.1 Locking system



Item No.: 890-111

Locking lever; for flying leads; for tool operation; black

Item No.: 890-131

Locking lever; for flying leads; for tool operation; white

Item No.: 890-101

Locking lever; for manual operation; black

Item No.: 890-121

Locking lever; for manual operation; white

1.2 Optional Accessories

1.2.1 Cover

1.2.1.1 Cover



Item No.: 897-2001

Protective cap; Type1; for sockets and plugs; PVC; red

1.2.2 Installation

1.2.2.1 Mounting accessories



Item No.: [890-310](#)

Mounting carrier; 2- to 5-pole; for flying leads; black



Item No.: [890-311](#)

Mounting carrier; 2- to 5-pole; for flying leads; white