

Wandcontactdoos

Bestelnr. 7027



- schroefklemmen
- X-CONTACT®
- magneetschakelaar en elektrische PKS vergrendeling

Technische informatie

Ampère	125 A
Polen	4 p
Voltage	230 V
Uurstand	9 h
Hertz	50-60 Hz
Aansluittechniek	schroefklemmen
Contacten	X-CONTACT®
Beschermingsgraad	IP 67
Behuizing materiaal	Kunststof
Gewicht	8500 g
Certificeringen	EAC

Tekeningen

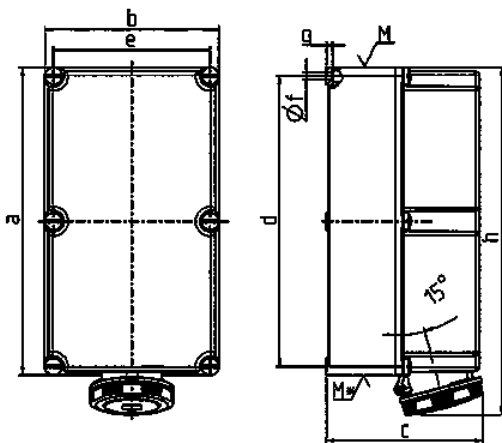

Tekening 1 MB 163	Amp. Polen	125	
		4	5
Maten in mm	a	460	460
	b	260	260
	c	234	234
	d	434	434
	e	234	234
	f	11	11
	g	9	9
	h	519	519
	M	63	63
	M*	2x63	2x63
Kabel Ø tot mm		44	44
Kabelaansluiting		25	25
van/tot mm ²		—70	—70