

Emergency Lighting
Self-contained luminaire system CGLine+

Simply the most flexible,
reliable monitoring
for peace of mind





All safety luminaires are important. They help protect the life and health of people.

Emergency lighting must be fully functional to provide protection in case of failure of the general lighting.

Even if a single safety luminaire or exit sign luminaire fails, depending on the particular local conditions, there is a significant risk of accidents, for example in a stairway. For this very reason legislation requires continuous testing of the emergency lighting. The operation of the luminaires in battery mode for example (function test) must be verified at least once a week.

Self-contained luminaires without an automatic test function

The function test is performed in case of single self-contained luminaires by pressing a button on the luminaire, and the result must be recorded by hand in a log book. An additional duration test for the duration of the rated operating time (1, 3 or 8 hours) must be performed once a year. This test checks whether there is still sufficient battery capacity available. All log book entries must be kept on file for 4 years. If there are a large number of luminaires, manual testing is an extremely laborious process and therefore involves significant costs.

Automatic testing simplifies the process

Eaton has implemented automatic test functions in all CGLine+ self-contained luminaires. A microprocessor monitors and controls all functions of the luminaires automatically. The required tests, the function test and the duration test, are performed automatically. The test results are shown on site on the luminaire by a status indicator. Without a central monitoring device, the results must be recorded by hand in the log book and kept on file in paper form for at least 4 years.

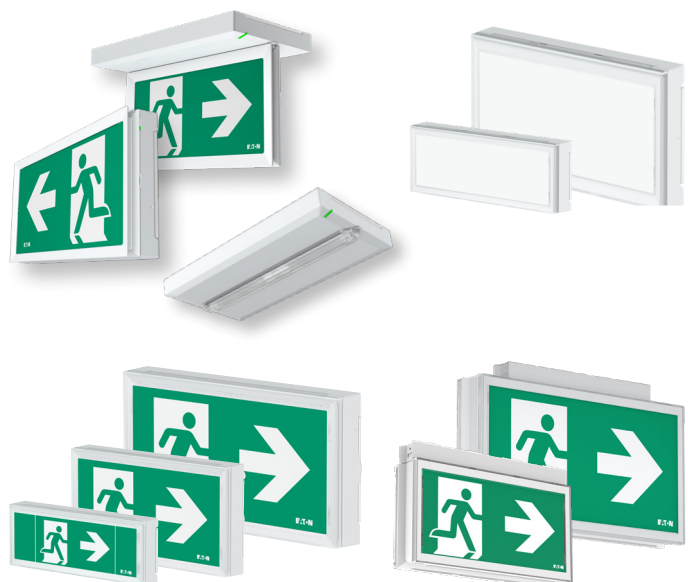

New FlexiTech range : Flexible and easy emergency lighting

Central controller provides more safety

The CGLine+ Controllers initiate the tests, display the results centrally and store them with ease in a paperless form in an electronic log book. The electronic log book can be printed off and shown on demand. This process ensures the safe operation of the building, and the building operator meets his duty of documentation.

CGLine+ self-contained luminaire system

Enhanced safety by providing reliable and efficient monitoring

CGLine+: More luminaires. More convenience. More safety!

CG+_{Line} The new CGLine+ system is a more powerful system to make the operation of self-contained luminaire systems safer and even more convenient.



CGLine+ Web Controller



CGLine+ Web Compact Controller

Now up to 800 luminaires monitored

The CGLine+ Web Controller can visualise a total of 800 CGLine+ luminaires (four lines of maximum 200 luminaires each or two lines of maximum 400 luminaires each). The number of luminaires is doubled as compared to the monitoring capacity of a controller of the CGLine 400 system. This lowers investment costs for larger-scale projects.

Typical installation with max. 2 lines of 400 luminaires each (left) or 4 lines of 200 luminaires each (right).

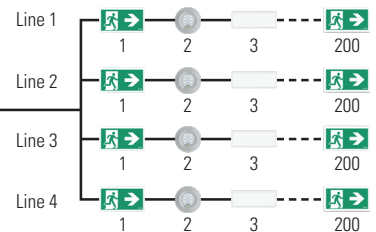
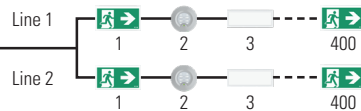

Built-in keypad and LCD screen in a single housing

The new CGLine+ Web Compact Controller includes the functionalities of the CGLine+ Web Controller with a built-in keypad and LCD screen in a single housing for a friendly usage. Depending of the variant, this controller can visualize a total of 160 or 400 CGLine+ luminaires (2 lines with max. 80 or 200 luminaires each).

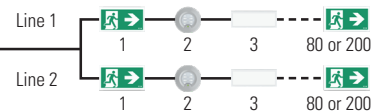

Addressing CGLine+ luminaires

Luminaires do not need to be manual addressed in the CGLine+ system. CGLine+ luminaires are fitted with a unique address by the manufacturer consisting of a six-digit ID number in hex code format. Using this address the Controllers identify the luminaires automatically when the system is launched.

In addition, each luminaire can be configured to receive a short digital address and an individual name with a maximum of 20 characters. Hence it is possible to use a name which corresponds to the name of the location according to the planning documents. This simplifies the localisation of luminaires in the building and additional repair procedures can even be remotely planned in case of failure.

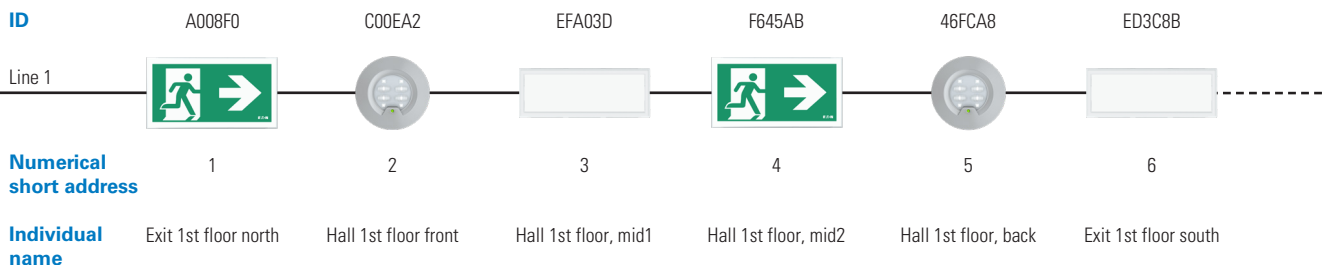



Safety under control worldwide

An integrated web server is available for convenient visualisation, control and monitoring of all connected CGLine+ luminaires. The controller can be accessed from any PC with an IP connection and a regular web browser without requiring any special software. The controller provides an overview of faulty luminaires, regardless of where the maintenance personnel are located. Safety issues caused by failed luminaires can be evaluated and the relevant correct measures can be implemented. Regardless of location, completed maintenance works can then be conveniently checked. This means greater efficiency for the building operator, making it simpler to meet his obligations to eliminate any safety hazards as quickly as possible.

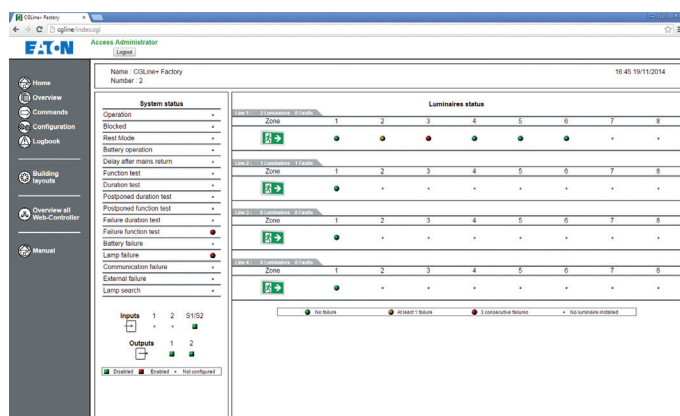
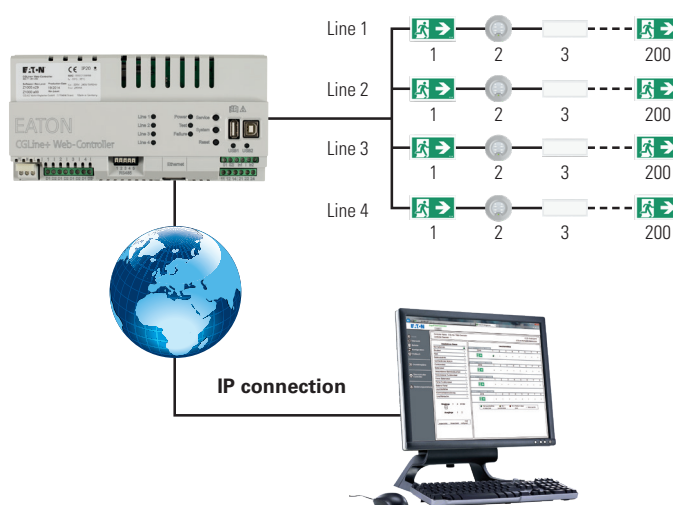

Presentation of zones on the first page in a browser view

Maintain an overview: Allocate the luminaires to zones

Maintaining an overview is important if there are a large number of luminaires. Luminaires of each line can be allocated to up to 8 zones (up to 16 zones in case of installing only two lines). The zones can be areas where the luminaires need be brought together, for example on a floor, in an area or in a room. The exit sign luminaires can be switched off or blocked in different parts of a building which are not being used at certain times. By doing this, energy costs are reduced. By blocking the signs, unintentionally discharging batteries when the mains power is switched off is avoided, for example when maintenance work is being carried out. The zone can be used immediately after turning on the mains power, because batteries have not been discharged and the luminaires can perform their safety function immediately being unblocked.

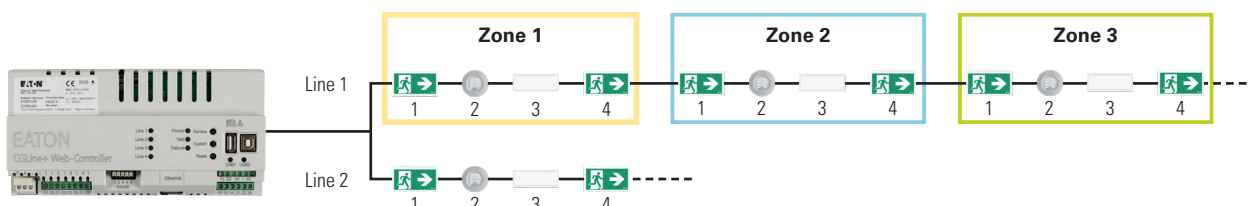

CGLine+ self-contained luminaire system

Enhanced safety by providing reliable and efficient monitoring

Tests are not forgotten, and are carried out at the right intervals for maximum safety

The timing and the intervals of regular function and duration tests can be conveniently and precisely set down to the minute, ensuring that the equipment is ready for operation at any time during the operating hours of the building. This allows luminaires to be grouped into up to eight test groups for this purpose, for example to ensure that duration testing of luminaires installed next to each other is not started at the same time. The image below shows the luminaires of a floor allocated into two test groups. The period between tests is completely adjustable.

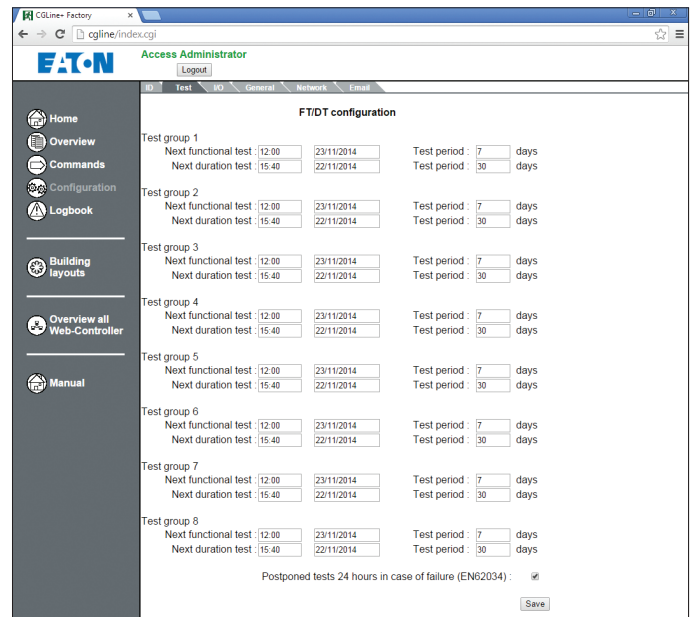

The advantages of test groups: Up to eight test groups can be created for testing in order to guarantee the operational readiness of the entire system.

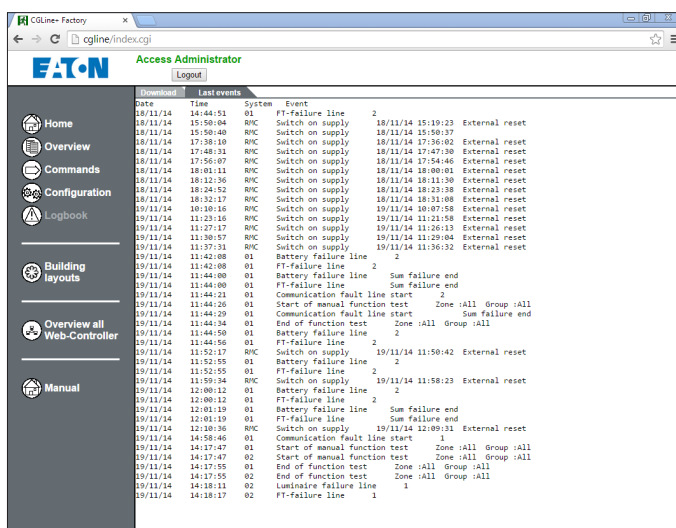
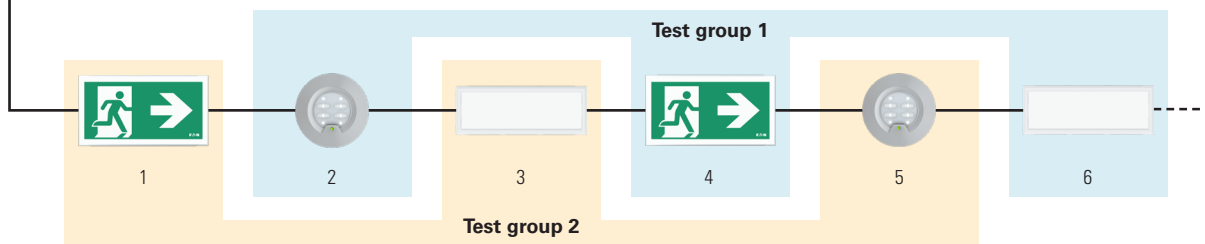

The log book is available at any time using a web browser. Data are stored for at least four years in compliance with standards.

The electronic log book saves the need for manual logging

All test results are stored in the electronic log book for at least four years, in compliance with standards. The data is available directly using a web browser. The log book can be downloaded directly from the controller through a web server for further analysis of the log book in TXT or DAT file format. The DAT file can then be stored and transported using a regular USB memory stick. The CGLine+ PC software is used for reading the log book in DAT format, providing efficient and convenient analysis of the test results.

The electronic log book simplifies the requirement for the building operator to provide documentation, and it removes the need for laborious, manual logging.

CGLine+ self-contained luminaire system

Enhanced safety by providing reliable and efficient monitoring



Cybersecurity tested

There's no need to take chances with connected solutions. Our products are tested in our specialized labs certified for IEC and UL Cybersecurity. Customers can rest easier, knowing Eaton devices are compliant with the highest industry cybersecurity requirements before they're installed in critical systems.

Security has further been reinforced in the CGLine+ controllers to meet the latest requirements:

- Three levels of passwords
- Secure communications with HTTPS for web server encryption
- TLS email encryption
- New guidelines to securely deploy the CGLine+ controllers and minimize the cybersecurity risk to the installer system.

Automatic e-mail notification in case of faults

The integrated e-mail service automatically sends e-mails to up to ten recipients in case of allocatable events, for example in case of a luminaire failure being detected following an automatic function test. The aim of this function is to actively notify without delay those persons responsible for building safety about any faults, even if they have no direct connection with the controller at that point in time.

E-mail addresses can be divided into two groups to implement hierarchical escalation. This ensures that when a recipient in the first group is unexpectedly absent, other people are informed to ensure the safety of visitors of the building.

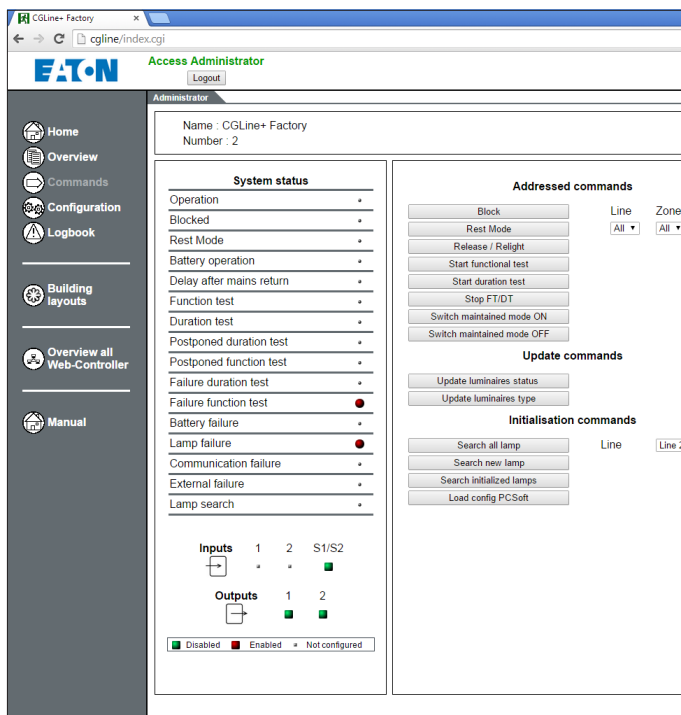

Selective assignment of commands

The web browser interface is useful for:

- Blocking/unblocking instructions
- Manual starting/stopping the function test and duration tests
- Switching on/off maintained light

This can be done in detail for all luminaires, for a line, for a zone and down to individual luminaires.

Furthermore this view offers a system status overview with the most important status messages and the operating condition of the input and output contacts.

Easy luminaire replacement with web server

It is now possible to configure luminaires addresses and IDs similar to how it can be done with the CGLine+ PC software. This can be used to add, exchange, remove some luminaires from an installation with the web server interface only.

Multiple languages

More and more languages are supported by the CGLine+ controllers:

English, Czech, Dutch, French, German, Greek, Hebrew, Hungarian, Italian, Luxembourgish, Norwegian, Polish, Portuguese, Spanish, Swedish, etc..

CGLine+ self-contained luminaire system

Enhanced safety by providing reliable and efficient monitoring

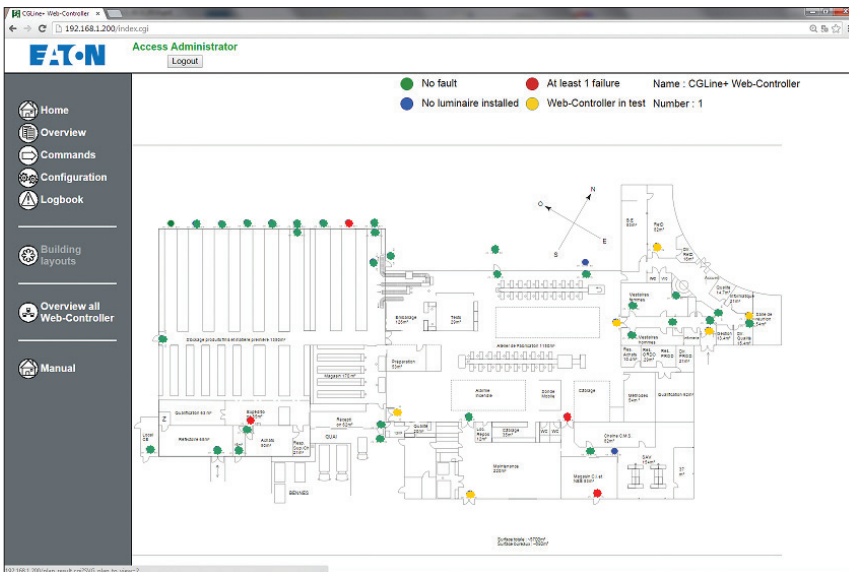

Keep your bearings in complex buildings

The programming of building layout function offers new opportunities. Building layouts can be loaded in the program to display the status of luminaires at the installation location on the floor. Up to 30 different building layouts can be displayed for each controller. Luminaires are displayed with colour codes according to their current status. By touching a luminaire with the mouse pointer, a status window opens up with more information about the luminaire.

The overview helps provide better orientation in the building. The situation can be judged more effectively and repairs better prioritised.

Compatibility with the CGLine 400 System

The comprehensive functionality of the CGLine+ controller can only be used in conjunction with CGLine+ luminaires. However, CGLine+ luminaires and CGLine 400 luminaires can be connected to the CGLine+ controller in a straightforward manner in a mixed setup. In this set-up, the controller operates in CGLine 400 mode only. The extended CGLine+ functions can be used only when only unmixed CGLine+ luminaires are installed. The new CGLine+ luminaires can also be used together with the proven CG controller CGLine 400 in CGLine 400 mode.

	CGLine+ luminaires	CGLine 400 luminaires
CGLine+ Controller	CGLine+ mode	CGLine 400 mode
CGLine 400 Controller	CGLine 400 mode	CGLine 400 mode

Comprehensive CGLine+ functions using CGLine+ luminaires connected to a CGLine+ controller

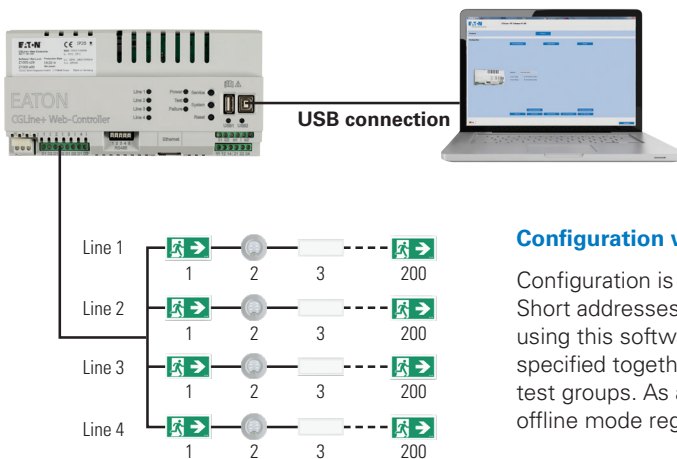

Configuration with PC software

Configuration is carried out using the CGLine+ PC software. Short addresses and unique names of luminaires can be assigned using this software; the time and interval of automatic tests are specified together with the zone assignment and the definition of test groups. As a result, the entire system can be configured in offline mode regardless of whether the IT network is available.

CGLine+ monitoring Increased Affordance

Increased Affordance portfolio



The Increased Affordance functionality has been added to selected emergency luminaires within Eaton's lighting range, including CrystalWay, FlexiTech, RoundTech and Nexitech.

This fully programmable function can be activated manually or automated to respond to a preset trigger such as a fire alarm, panic button or other system. Eaton's Increased Affordance solution has been developed and tested by an engineering team with decades of expertise in emergency lighting.



CrystalWay



NexiTech IA



RoundTech MR EC



FlexiTech EW & CW



FlexiTech EC & CC



FlexiTech ED



CGLine+ Web Controller

When connected to Eaton's monitoring and control system for emergency lighting, CGLine+, the exit sign luminaires are able to provide either soft pulsing or on-and-off flashing. In their normal mode, the luminaires offer excellent visibility thanks to a high level of contrast that exceeds the minimum requirement in most countries. When activated, Increased Affordance enables even better recognition by flashing or pulsing but never dipping below the minimum level of luminescence that is established in industry standards, thus achieving full compliance. The IA function can be started either in normal maintained mode or in emergency lighting mode because an evacuation is not necessarily linked to a mains failure. The IA function will remain activated for 30 minutes (typical evacuation times are lower) before the luminaire switches back to normal operation.



CGLine+ Web Compact controller

Luminance in the green zone of an IA luminaire (flashing or pulsing) compared with the minimum luminance in battery mode defined by EN1838:

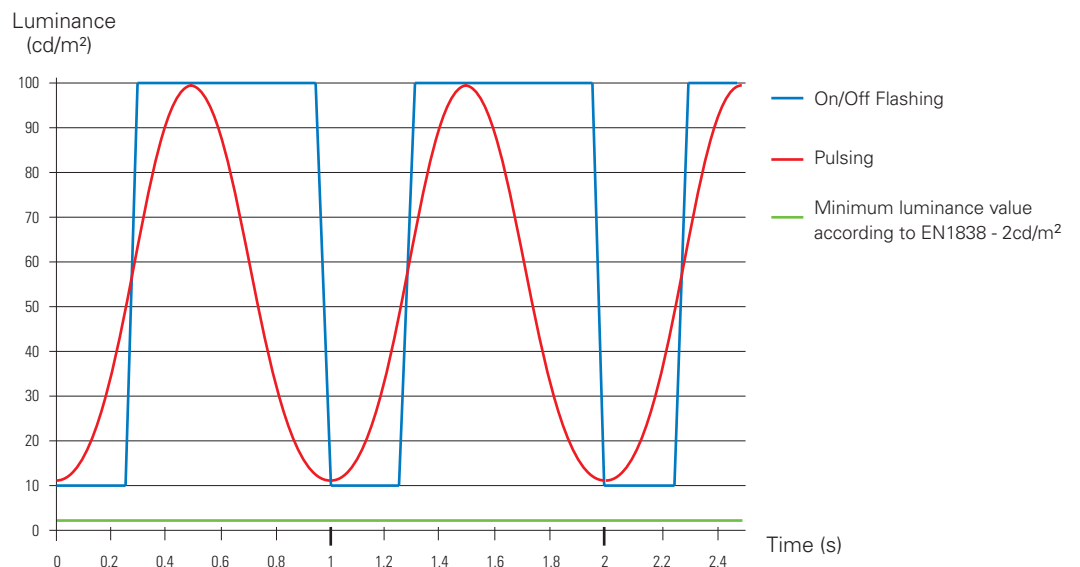

Basic configuration with Controller

- One input signal will activate blinking of all luminaires connected to a line
- Select activation of all lines or single lines
- One controller for both: Standard CGLine+ and IA luminaires can be controlled via the same controller

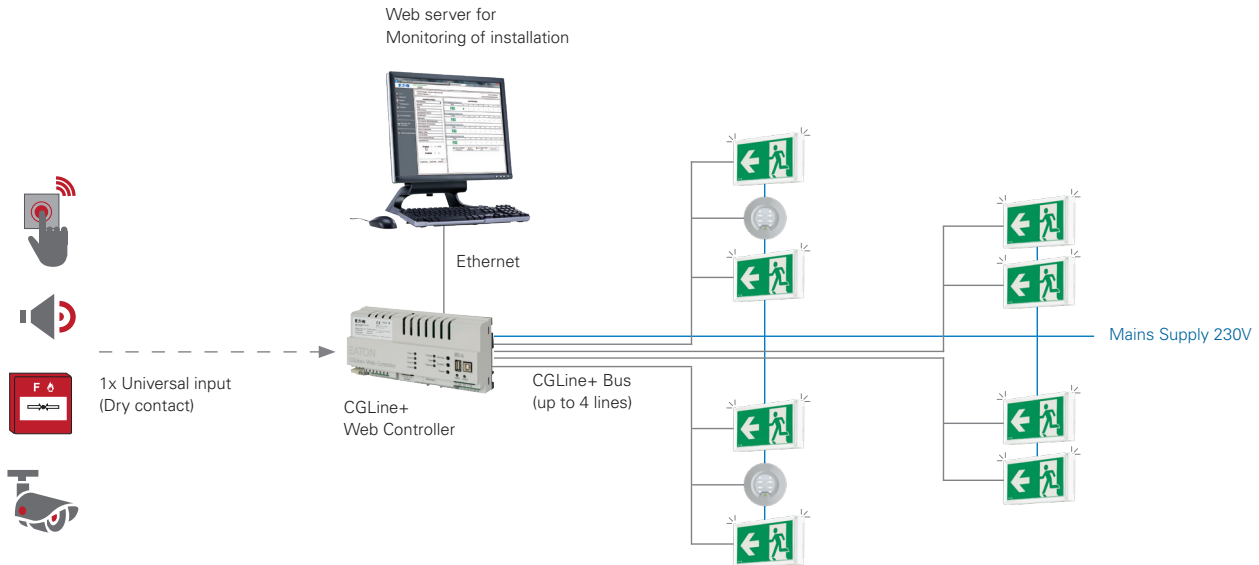

Advanced configuration

- Scenarios will be activated via inputs (switch contacts)
- The programming will be via the PC Software
- Every single luminaire can be assigned to IA scenarios
- One controller for both: Standard CGLine+ and IA luminaires can be controlled via the same controller

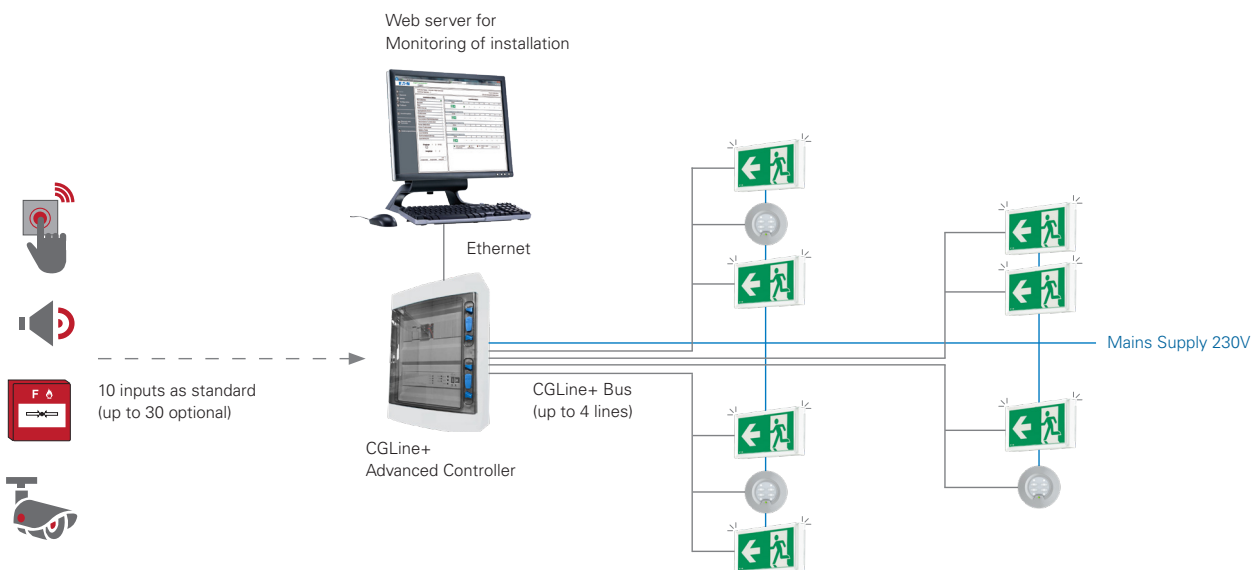

CGLine+ self-contained luminaire system

CGLine+ Web Controller

CGLine+ Bus

The communication of all data and commands takes place using the CGLine+ bus installed in a free topology using a two-wire unshielded cable. Should there be a possible break in the bus cable, the additional integrated test function of each CGLine+ luminaire ensures that the tests required are performed automatically, and this is displayed on site at the luminaire. The required cross-section of the bus cable depends on the length of the wire.

Cable length of a line

Wire cross-section	Max length of a branch (Distance to farthest luminaire)	Max total cable length per line
0.5 mm ² *	260 m	660 m
1.0 mm ²	520 m	1.320 m
1.5 mm ²	800 m	2.000 m

* e.g. J-Y(ST)Y 2x2x0,8

Electrical data per line/bus

Supply voltage Bus	Max. allowable voltage drop	Bus current
25 V DC	6 V	400 mA

Set-up of the CGLine+ Web Controller

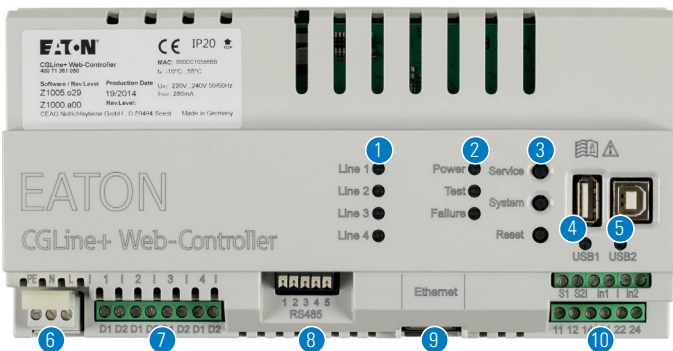

1 LEDs for line 1 to line 4:

It signals the sending or receiving of data between the CGLine+ Web Controller and the CGLine+ self-contained luminaires.

- Green LED = Receiving of data by the Web Controller

- Yellow blinking LED = Sending data to the luminaires

2 Power LED:

The green light is lit as soon as the controller is connected to the 230V/AC supply voltage.

Test LED:

- Rapid green blinking if at least 1 luminaire is undergoing a function test
- Rapid green blinking if at least 1 luminaire is undergoing a duration test

LED failure:

Showing a sum failure. Red LED light is lit if at least 1 luminaire is faulty, for example the battery has failed

3 Button:

- Service = Starts a function test for example
- System = Starts a USB connection using the USB2 port
- Reset = Hardware reset of the device

4 USB1 port (Host) for

connecting a regular USB memory stick

5 USB2 port (Device), for

connecting to a PC

6 PE/N/L 230V 50/60Hz

7 Connections for the CGLine+ bus, line 1 to line 4

8 RS485

9 LAN (RJ45) with LED display

- green = connected (link)
- yellow = data transfer (traffic)

10 Digital inputs and outputs:

- S1/S2 = Blocking input
- In1, In2 = 2 x digital inputs
- 11, 12, 14 / 21, 22, 24 = 2 x relay outputs

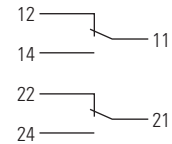

CGLine+ in operation

CGLine+ Web Controller: With integrated memory for storing the configuration and the log book

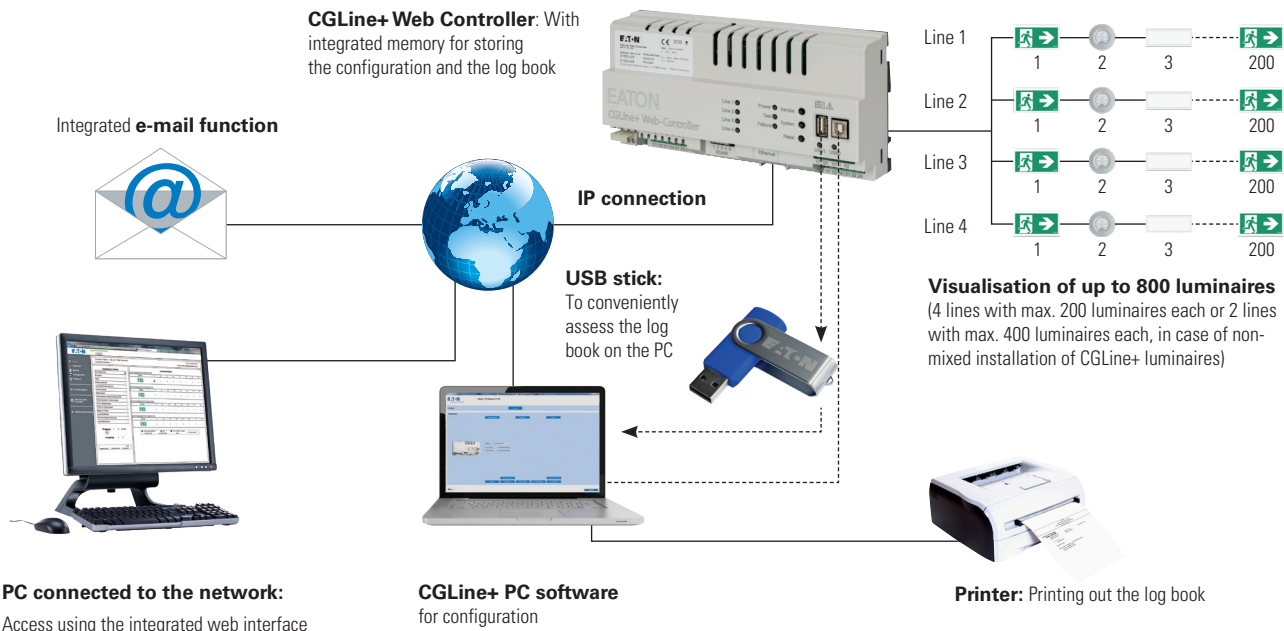

Integrated e-mail function

IP connection

USB stick:
To conveniently assess the log book on the PC

Visualisation of up to 800 luminaires
(4 lines with max. 200 luminaires each or 2 lines with max. 400 luminaires each, in case of non-mixed installation of CGLine+ luminaires)

PC connected to the network:
Access using the integrated web interface

CGLine+ PC software
for configuration

Printer: Printing out the log book

CGLine+ Web Controller with integrated web server



Dimensional drawings, data in mm

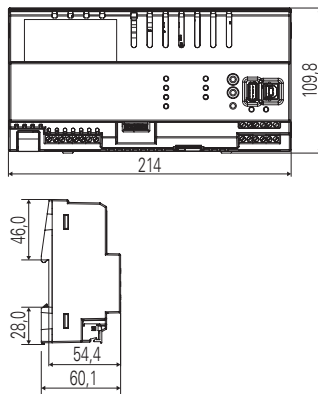

Advanced IA CGLine+ system



CGLine+ Web Controller

- Connection of up to 800 luminaires in max. 4 lines
- The integrated web server enables convenient visualisation, control and monitoring
- Compatible with the Increased Affordance (IA) functionality: In case of an evacuation, the controller can send an IA command to all connected Exit signs with IA CGLine+ functionality. With this command, the luminaires will start to flash (on/off or smooth pulsing)
- Selection of blinking scheme and line to start with the IA function can be programmed via the PC. The IA function is triggered by closing a potential free contact at the controller.
- For more complex situations an Advanced IA CGLine+ system can be used which includes an input module for 10 or 20 scenarios. This enables an individual programming of which luminaires will react to a scenario. By that the IA be started individually e.g. for different building sections.
- The communication between the input module and the controller is constantly monitored and any failure is reported at the Web Controller, as well as being delivered by email report.
- Within a CGLine+ system standard CGLine+ luminaires can easily be combined with IA CGLine+ luminaires
- Each luminaire is assigned with a unique ID by the manufacturer
- Automatic luminaire search function requires no manual addressing
- Simple sorting using unrestricted short address assignment
- Unrestricted entry of target location names for the luminaires with up to 20 characters
- Allocation of luminaires - up to 8 zones per line – is clearly displayed
- Automatic function test and duration test
- Web Controller tested and approved by BSI: KM No. 636748 - Automatic test system for Battery Powered Emergency lighting to EN 62034
- Up to 8 test groups per luminaire can be defined for the function test (FT) and duration test (DT)
- Electronic logbook storage for a period of minimum 4 years
- Email service for sending automatic email (in case of malfunction) to up to 10 e-mail addresses, assignable to 2 escalation groups
- Blocking of the emergency lighting function during non-operational periods (all/per bus line/per zone/per luminaire)
- Luminaires in maintained mode switchable (all/per bus line/per zone/per luminaire)
- Password protected access as an administrator or user
- Visualisation of luminaires in up to 30 different building layouts
- Efficient and convenient analysis of the log book using the CGLine+ PC software

	Web Controller	Advanced IA CGLine+ system (without backup)
Dimensions	214 x 109.8 x 60.1 mm	310 x 145 x 436 mm
Housing type	For DIN rail 12 HP	ABS
Power supply	230 V AC, 50/60 Hz	230 V AC, 50/60 Hz
Power consumption	< 4W in standby, < 21W at full load	22W (max load)
Connection terminals	max. 2.5 mm ²	max. 2.5 mm ² (CGLine+ bus: 1.5 mm ²)
Permissible ambient temperature	0 °C ... 35 °C	0 °C ... 35 °C
Storage temperature	-20 °C ... 70 °C	
Degree of protection	IP20	IP65

Ordering details

Type	Scope of supply	Order No.
CGLine+ Web Controller	Controller, for DIN rail mounting	40071361055
Advanced AE/IA CGLine+ System, 10 inputs	Including Advanced CGLine+ Web Controller, input module for 10 trigger inputs, wall mount housing (plastic)	40071777994
Advanced AE/IA CGLine+ System, 20 inputs	Including Advanced CGLine+ Web Controller, input module for 20 trigger inputs, wall mount housing (plastic)	40071777995

Accessories

Type	Scope of supply	Order No.
CGLine+ PC software	on CD-ROM	40071361178

CGLine+ self-contained luminaire system

CGLine+ Web Compact Controller

CGLine+ Bus

The communication of all data and commands takes place using the CGLine+ bus installed in a free topology using a two-wire unshielded cable. Should there be a possible break in the bus cable, the additional integrated test function of each CGLine+ luminaire ensures that the tests required are performed automatically, and this is displayed on site at the luminaire. The required cross-section of the bus cable depends on the length of the wire.

Cable length of a line

Wire cross-section	Max length of a branch (Distance to farthest luminaire)	Max total cable length per line
0.5 mm ² *	260 m	660 m
1.0 mm ²	520 m	1.320 m
1.5 mm ²	800 m	2.000 m

* e.g. J-Y(ST)Y 2x2x0,8

Electrical data per line/bus

Supply voltage Bus	Max. allowable voltage drop	Bus current
25 V DC	6 V	400 mA

Set-up of the CGLine+ Web Compact Controller



1 Status LED indicator for the EL installation:

- Green = OK
- Green blinking = at least 1 luminaire is performing a function test or duration test
- Red : Failure / event

2 TFT LCD screen with all menu, parameters and alarms

3 Keypad for navigation in the menu and set parameters

4 USB-1 host, for connecting a USB stick with LED indicator

5 USB2 device, for connecting to PC with LED indicator

6 LAN (RJ45), with LED display

- Green = connected (link)
- Yellow = data transfer (traffic)

7 Cables entries for :

- Connection CGLine+ bus line 1-2
- PE/L/N 230V 50/60Hz
- S1/S2 = Block input
- In1, In2 = 2 x digital inputs
- 11, 12, 14, 21, 22, 24 = 2x relay outputs

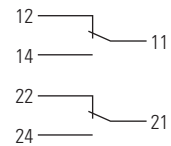

CGLine+ in operation

CGLine+ Web Compact Controller:
With integrated memory for storing the configuration and the log book

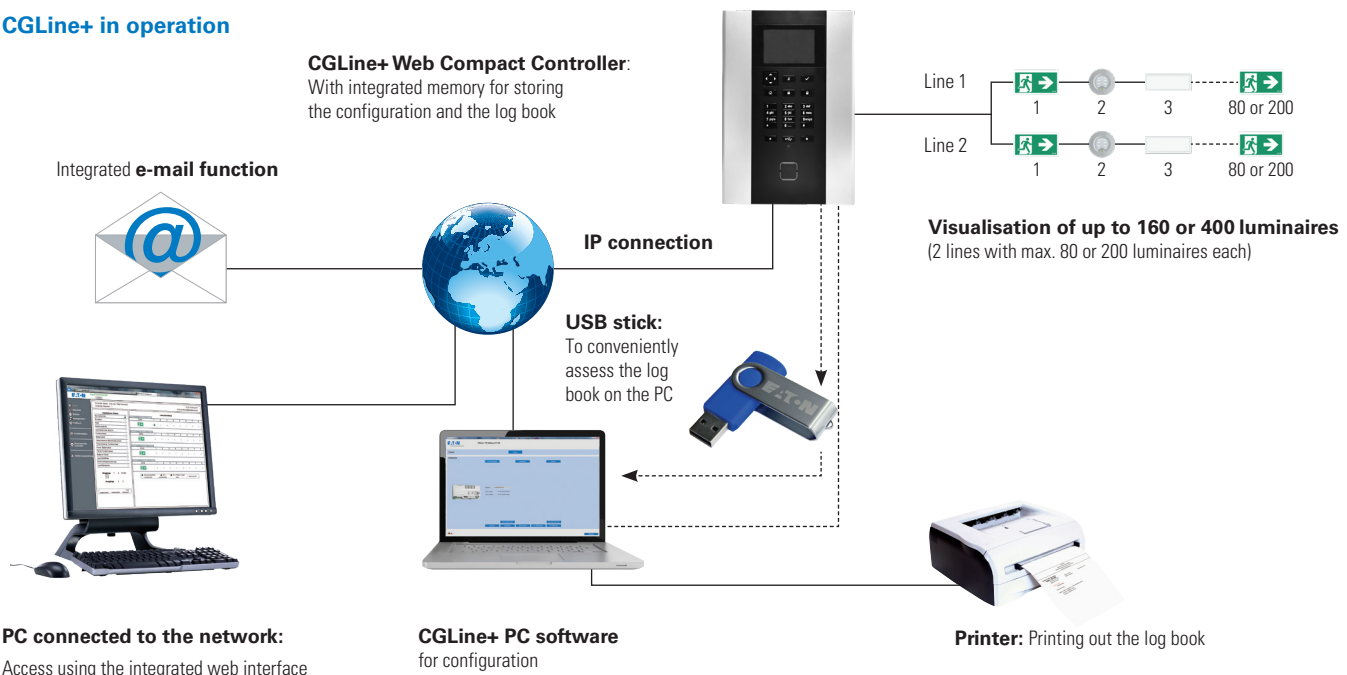

Integrated e-mail function

IP connection

USB stick:
To conveniently assess the log book on the PC

Visualisation of up to 160 or 400 luminaires
(2 lines with max. 80 or 200 luminaires each)

PC connected to the network:
Access using the integrated web interface

CGLine+ PC software
for configuration

Printer: Printing out the log book

CGLine+ Web Compact Controller with integrated web server



Dimensional drawings, data in mm

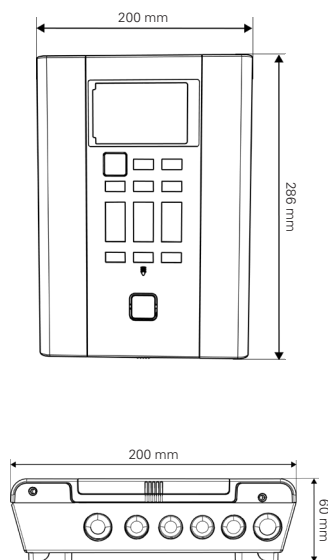

CGLine+ Web Compact Controller

- For connecting up to 160 or 400 CGLine+ luminaires in 2 lines
- HMI with TFT LCD screen 320*480 and keypad
- LED status for EL installation
- The integrated web server enables there to be convenient visualization, control and monitoring
- Up to 9 additional Web Compact Controllers managed within the same web server connection
- Unique ID per luminaires assigned by the manufacturer
- Automatic luminaire search function requiring no manual addressing
- Simple sorting using unrestricted short address assignment
- Unrestricted entry of target location names for the luminaires with up to 20 characters
- Clearly-shown allocation of luminaires to 4 zones of 20 (160 variant) or 50 (400 variant) luminaires per line
- Automatic function test and duration test
- Up to 8 test groups per luminaire can be defined for the function test (FT) and duration test (DT)
- Electronic log book storage for a period of minimum 4 years
- E-mail service for sending automatic e-mail in case of malfunctions to up to 10 e-mail addresses, assignable to 2 escalation groups
- Blocking the emergency lighting function during non-operational periods (all/per bus line/ per zone/per luminaire)
- Luminaires in maintained mode switchable (all/per bus line/per zone/per luminaire)
- Password protected access as an administrator or user
- Visualisation of luminaires in up to 30 different building layouts with the web server
- Efficient and convenient analysis of the log book using the CGLine+ PC software
- Compliant with the highest industry cybersecurity requirements
- Maintenance and replacement of luminaire with the local HMI
- Maintenance and replacement of luminaire with the web server interface
- Compatible with the Increased Affordance (IA) functionality: In case of an evacuation, the controller can send an IA command to all connected Exit signs with IA CGLine+ functionality. With this command, the luminaires will start to flash (on/off or smooth pulsing)

Dimensions	288 x 203 x 60 mm
Housing type	Wall mounted
Screen	TFT LCD screen 320 x 480
Power supply	230 V AC, 50/60 Hz
Power consumption	< 4W in standby, < 34W at full load
Connection terminals	max. 2.5 mm ²
Permissible ambient temperature	0 °C ... 35 °C
Storage temperature	0 °C ... 35 °C
Degree of protection	IP20

Ordering details

Type	Scope of supply	Order No.
CGLine+ Web Compact Controller 160	Wall mounted controller with LCD screen and keypad	CTR160CGL2KS
CGLine+ Web Compact Controller 400	Wall mounted controller with LCD screen and keypad	CTR400CGL2KS

Accessories

Type	Scope of supply	Order No.
CGLine+ PC software	on CD-ROM	40071361178

Eaton is an intelligent power management company dedicated to improving the quality of life and protecting the environment for people everywhere. We are guided by our commitment to do business right, to operate sustainably and to help our customers manage power today and well into the future. By capitalizing on the global growth trends of electrification and digitalization, we're accelerating the planet's transition to renewable energy, helping to solve the world's most urgent power management challenges, and doing what's best for our stakeholders and all of society.

Founded in 1911, Eaton is marking its 100th anniversary of being listed on the New York Stock Exchange. We reported revenues of \$20.8 billion in 2022 and serve customers in more than 170 countries.

For more information, visit **Eaton.com**.

Eaton Industries Manufacturing GmbH
Electrical Sector EMEA
Route de la Longeraie 7
1110 Morges, Switzerland
Eaton.eu

Changes to the products, to the information contained in this document, and to prices are reserved; so are errors and omissions. Only order confirmations and technical documentation by Eaton is binding. Photos and pictures also do not warrant a specific layout or functionality. Their use in whatever form is subject to prior approval by Eaton. The same applies to Trademarks (especially Eaton, Moeller, Cutler-Hammer and CEAG). The Terms and Conditions of Eaton apply, as referenced on Eaton Internet pages and Eaton order confirmations.