

Data Sheet | Item Number: 252-308

2-conductor female connector; push-button; PUSH WIRE®; 0.8 mm Ø; Pin spacing 3.5 mm; 8-pole; for individual solder pins; for KNX; gray

<https://www.wago.com/252-308>

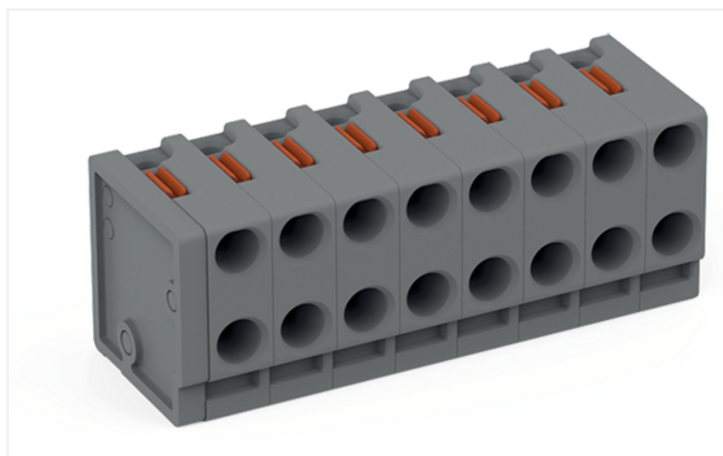

Color: ■ gray

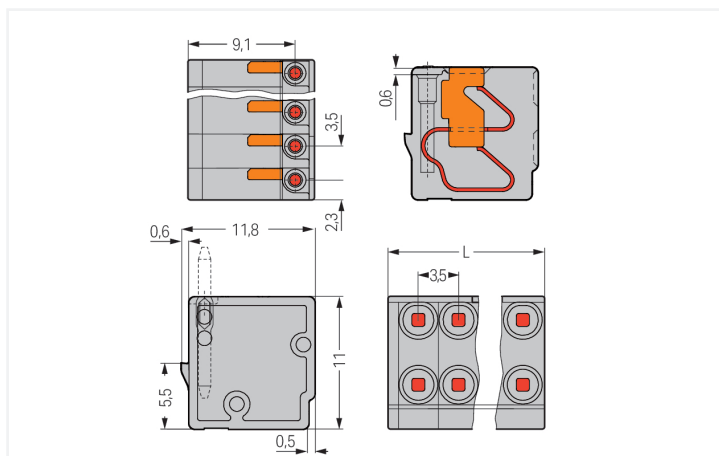

Dimensions in mm
L = pole no. x pin spacing

Pluggable pcb terminal block, 252 Series, with 3.5 mm pin spacing

Our pluggable pcb terminal block (item number 252-308) is designed for seamless electrical installations. Strip lengths must be between 6 and 7 mm when connecting conductors to pluggable pcb terminal block. Featuring one conductor terminal along with PUSH WIRE®, this connector delivers reliable performance. Our PUSH WIRE® connection uses the stiffness of the conductor to overcome the clamping spring's contact force, allowing faster and easier conductor clamping. Dimensions: (28 x 11 x 10.5) mm (width x height x depth). Pluggable pcb terminal block is suitable for conductor cross sections ranging from 0.14 mm² to 0.5 mm². The contact surface is coated with tin.

Notes

Variants:

Other pole numbers
Direct marking
Other versions (or variants) can be requested from WAGO Sales or configured at <https://configurator.wago.com/>.

Electrical data

Ratings per	IEC/EN 60664-1		
	III	III	II
Overvoltage category	III	III	II
Pollution degree	3	2	2
Nominal voltage	160 V	160 V	320 V
Rated impulse withstand voltage	2.5 kV	2.5 kV	2.5 kV
Rated current	2 A	2 A	2 A

Approvals per	UL 1059		
	B	C	D
Use group	B	C	D
Rated voltage	300 V	-	300 V
Rated current	2 A	-	2 A

Connection Data

Clamping units	16
Total number of potentials	8
Number of connection types	1
Number of levels	1

Connection 1

Connection technology	PUSH WIRE®
Actuation type	Push-button
Solid conductor	0.14 ... 0.5 mm ² / 26 ... 20 AWG
Conductor diameter	0.4 ... 0.8 mm / 26 ... 20 AWG
Strip length	6 ... 7 mm / 0.24 ... 0.28 inches
Conductor connection direction to PCB	0°
Pole number	8

Physical data

Pin spacing	3.5 mm / 0.138 inches
Width	28 mm / 1.102 inches
Height	11 mm / 0.433 inches
Depth	10.5 mm / 0.413 inches

Plug-in connection

Contact type (pluggable connector)	Female connector/socket
Connector (connection type)	for PCB
Plugging without loss of pin spacing	Yes
Mating direction to the rail-mount terminal block	90 °

Material data

Note (material data)	Information on material specifications can be found here
Color	gray
Material group	I
Insulation material (main housing)	Polyamide (PA66)
Flammability class per UL94	V0
Clamping spring material	Copper alloy
Contact material	Electrolytic copper (E _{Cu})
Contact Plating	Tin
Fire load	0.076 MJ
Weight	3.6 g

Environmental requirements

Limit temperature range	-60 ... +105 °C
-------------------------	-----------------

Environmental Testing

Test specification: Railway applications – Rolling stock – Electronic equipment	DIN EN 50155 (VDE 0115-200):2022-06
Test procedure: Railway applications – Rolling stock equipment – Vibration and shock tests	DIN EN 61373 (VDE 0115-0106):2011-04
Spectrum/Mounting location	Service life test, Category 1, Class A/B
Functional test with noise-like oscillations	Test passed according to Section 8 of the standard
Frequency	f ₁ = 5 Hz to f ₂ = 150 Hz
Acceleration	0.101g (highest test level used for all axes)
Test duration per axis	10 min.
Test directions	X, Y and Z axes
Monitoring of contact faults and interruptions	Passed
Voltage drop measurement before and after each axis	Passed
Simulated service life test through increased levels of noise-like oscillations	Test passed according to Section 9 of the standard
Frequency	f ₁ = 5 Hz to f ₂ = 150 Hz
Acceleration	0.572g (highest test level used for all axes)
Test duration per axis	5 h
Test directions	X, Y and Z axes
Extended testing: Monitoring of contact faults and interruptions	Passed
Extended testing: Voltage drop measurement before and after each axis	Passed

Environmental Testing

Shock test	Test passed according to Section 10 of the standard
Shock pulse form	Half sine
Acceleration	5g (highest test level used for all axes)
Shock duration	30 ms
Number of shocks (per axis)	3 pos. und 3 neg.
Test directions	X, Y and Z axes
Extended testing: Monitoring of contact faults and interruptions	Passed
Extended testing: Voltage drop measurement before and after each axis	Passed
Vibration and shock stress for rolling stock equipment	Passed

Commercial data

PU (SPU)	200 (50) pcs
Packaging type	Box
Country of origin	PL
GTIN	4055143829557
Customs tariff number	85366990990

Product Classification

UNSPSC	39121409
ETIM 9.0	EC002643
ETIM 10.0	EC002643
ECCN	NO US CLASSIFICATION

Environmental Product Compliance

RoHS Compliance Status	Compliant, No Exemption
------------------------	-------------------------

Approvals / Certificates

Declarations of conformity and manufacturer's declarations



Approval	Standard	Certificate Name
Railway WAGO GmbH & Co. KG	-	Z00004410.000

Downloads

Environmental Product Compliance

Compliance Search			
Environmental Product Compliance 252-308			↓

Documentation

Additional Information			
Technical Section	03.04.2019	pdf 2027.26 KB	↓

CAD/CAE-Data

CAD data			
2D/3D Models 252-308			↓

CAE data			
ZUKEN Portal 252-308			↓

1 Compatible Products

1.1 System counterpart

1.1.1 Solder pin



[Item No.: 243-131](#)
THT single pin; silver-colored

1.2 Optional Accessories

1.2.1 Male connector

1.2.1.1 Solder pin



[Item No.: 243-131](#)
THT single pin; silver-colored

1.2.2 Marking

1.2.2.1 Marking strip



[Item No.: 210-332/350-202](#)
Marking strips; as a DIN A4 sheet; MARKED; 1-16 (240x); Height of marker strip: 3 mm; Strip length 182 mm; Horizontal marking; Self-adhesive; white



[Item No.: 210-332/350-204](#)
Marking strips; as a DIN A4 sheet; MARKED; 17-32 (240x); Height of marker strip: 3 mm; Strip length 182 mm; Horizontal marking; Self-adhesive; white



[Item No.: 210-332/350-206](#)
Marking strips; as a DIN A4 sheet; MARKED; 33-48 (240x); Height of marker strip: 3 mm; Strip length 182 mm; Horizontal marking; Self-adhesive; white

1.2.3 Tool

1.2.3.1 Operating tool



Item No.: 210-719

Operating tool; Blade: 2.5 x 0.4 mm; with a partially insulated shaft

Item No.: 210-647

Operating tool; Blade: 2.5 x 0.4 mm; with a partially insulated shaft; multicoloured

Installation Notes

Conductor removal

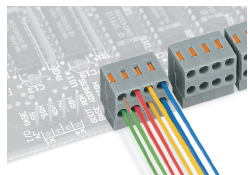

Conductor termination directly on the PCB or wiring prior to mounting on PCB – 252 Series

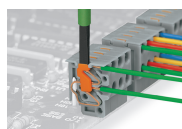

Removing a conductor – 252 Series

Installation

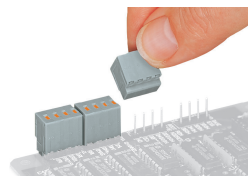

Plugging a compact PCB connector – 252 Series