

Data Sheet | Item Number: 771-6993/006-802

pre-assembled interconnecting cable; Eca; Socket/plug; 3-pole; Cod. A; H05VV-F
3G 1.5 mm²; 8 m; 1,50 mm²; white

<https://www.wago.com/771-6993/006-802>

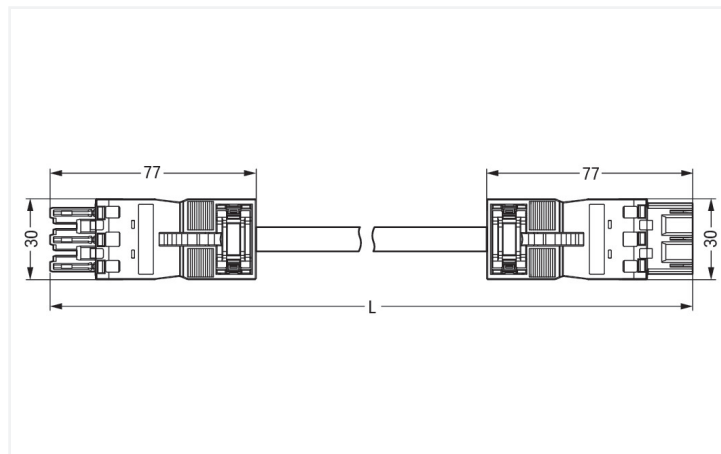

Color: ■ white

Similar to illustration

Dimensions in mm

Cable assembly WINSTA® MIDI with protection type IP2XD

For signal and power transmission: The WINSTA® MIDI cable assembly 3-pole. WAGO pluggable installation connectors are used when criteria repeat or are planned on a defined pattern, for example for installing grid lighting or flush-mount lighting. The coding options reduce installation errors, allowing fast, secure wiring of all components. The WINSTA® MIDI pluggable installation connector with A coding in white or black is normally used for general mains applications in power distribution. The WINSTA® MIDI Pluggable Connection System with Push-in CAGE CLAMP® spring pressure connection technology facilitates exemplary electrification. Thanks to the built-in test slot, connections can be checked even when they are plugged in. That saves time and reduces installation labor and expense. This product meets all the relevant fire protection requirements of fire class E; therefore it can be used in areas where fire safety is relevant.

Pluggable connections instead of screw connections – cable assemblies from WAGO

The cable is pre-assembled with a socket and a plug. WINSTA® is the pluggable connection system that is perfectly tailored to the strict requirements of electrical installation. It ensures fast, secure and, above all, error-free installation of components and cables. Now you can also lower installation expenses without compromising safety and quality: with protection type IP2XD reduces the need for servicing and prevents unnecessary downtime.

- effective protection against mismatching
- simple circuits
- with A coding for use in many general mains applications
- ready to install and use immediately
- convenient installation and commissioning

Notes

Note Cables with a different fire class can be found in the eShop.

Electrical data

Ratings per	IEC/EN 60664-1		
Overvoltage category	III	III	II
Pollution degree	3	2	2
Nominal voltage	250 V	-	-
Rated impulse withstand voltage	4 kV	-	-
Rated current	16 A	-	-

General information

Note on contact resistance approx. 1 mΩ of contact resistance
approx. 0.25 mΩ contact transition plug/
socket

Connection data

Total number of potentials	3	Connection 1	
PE function	Preceding PE contact	Pole number	3
		Wire cross-section	1.5 mm ²
		Connection type	Socket - Plug

Physical data

Pin spacing	10 mm / 0.394 inches
Width	30 mm / 1.181 inches
Height	12.9 mm / 0.508 inches
Total length	8 m

Mechanical data

Use	General mains applications
Coding	A
Variable coding	Yes
Marking	L ⊕ N
Potential marking	L ⊕ N
Mating force of a plug-in connection	approx. 20 ... 70 N (depending on pole number)
Retention force of a plug-in connection	when locked: > 80N
Unmating force of a plug-in connection	when unlocked: approx. 20 ... 70 N (depending on pole number)
Number of mating cycles	200, without resistive load
Connection type	Socket - Plug
Type of pre-assembled cable	Interconnecting cable
Cable type	H05VV-F 3G1.5
Protection type	IP2XD; When mated: IP2xC (These compact connectors are not designed for use in open, easily accessible areas!)

Plug-in connection

Mismating protection	Yes
Note on mismating protection	All <i>WINSTA</i> ® components are 100% protected against mismating when: a.) plugging different numbers of poles b.) plugging while rotated 180 c.) plugging while laterally staggered d.) plugging one pole
Locking lever	Can be retrofitted
Locking of plug-in connection	Locking lever
Note on locking system	All connectors for mounted installations (snap-in versions for lighting fixtures or devices, all types of PCB and distribution connectors) are factory-equipped with locking levers to ensure plugs and sockets are securely locked. Additional locking levers are only required for flying leads (plug/socket).

Material data

Note (material data)	Information on material specifications can be found here
Color	white
Insulation material (main housing)	Polyamide (PA66)
Fire class per EN 50575	E _{ca}
Contact material	Copper or copper alloy; surface-treated
Contact Plating	Tin
Fire load	240.02 MJ
Connector color	white
Strain relief color	white
Sheathed cable color	white
Printing color of sheathed cable	black

Material data

Halogen-free	No
Silicon-free	Yes
Sheath material	PVC
Rubber cable	No
Weight	829.5 g
Copper weight of the raw cable	0.043 kg/m

Environmental requirements

Processing temperature	-5 ... +40 °C
Continuous operating temperature	-35 ... +85 °C
Note on continuous operating temperature	Cable for temperatures ≤ 70 °C (including halogen-free) Insulating parts for temperatures ≤ 105 °C

Commercial data

PU (SPU)	1 pcs
Packaging type	unpacked
Country of origin	DE
GTIN	4055143488051
Customs tariff number	85444290900

Product Classification

UNSPSC	26121629
eCl@ss 10.0	27-44-06-04
eCl@ss 9.0	27-44-06-04
ETIM 9.0	EC002587
ETIM 10.0	EC002587
ECCN	NO US CLASSIFICATION

Environmental Product Compliance

RoHS Compliance Status	Compliant, No Exemption
------------------------	-------------------------

Approvals / Certificates

General approvals



Approval	Standard	Certificate Name
CCA DEKRA Certification B.V.	IEC 61535	NTR NL-7355
KEMA/KEUR DEKRA Certification B.V.	EN 61535	71-123834

Declarations of conformity and manufacturer's declarations

Approval	Standard	Certificate Name
EU-Declaration of Confor- mity WAGO GmbH & Co. KG	-	-
UK-Declaration of Confor- mity WAGO GmbH & Co. KG	-	-

Downloads

Environmental Product Compliance

Compliance Search

Environmental Product Compliance
771-6993/006-802



Documentation

Bid Text

771-6993/006-802	19.02.2019	xml 2.96 KB	
771-6993/006-802	13.01.2015	doc 25.00 KB	

CAD/CAE-Data

CAE data

EPLAN Data Portal
771-6993/006-802



WSCAD Universe
771-6993/006-802



1 Compatible Products

1.1 Required Accessories

1.1.1 Locking system

1.1.1.1 Locking system



[Item No.: 770-101](#)

Locking lever; for flying leads; for manual operation; black

[Item No.: 770-121](#)

Locking lever; for flying leads; for manual operation; white

[Item No.: 770-111](#)

Locking lever; for flying leads; for tool operation; black

[Item No.: 770-131](#)

Locking lever; for flying leads; for tool operation; white

1.2 Optional Accessories

1.2.1 Cover

1.2.1.1 Cover



[Item No.: 770-201](#)

Lockout cap; 12-pole, separable; for sockets; Plastic; black

[Item No.: 770-221](#)

Lockout cap; 12-pole, separable; for sockets; Plastic; white

[Item No.: 770-360](#)

Lockout cap; for plugs; 5-pole; separable; yellow

1.2.2 Installation

1.2.2.1 Mounting accessories



Item No.: 770-310

Mounting carrier; 2- to 5-pole; for flying leads; black

1.2.3 Marking

1.2.3.1 Marking strip



Item No.: 210-334

Marking strips; as a DIN A4 sheet; Strip width 5 mm; Strip length 182 mm; plain; Self-adhesive; white