

# Data Sheet | Item Number: 739-117/000-005

PCB terminal block; 2.5 mm<sup>2</sup>; Pin spacing 5 mm; 17-pole; CAGE CLAMP®; red

<https://www.wago.com/739-117/000-005>

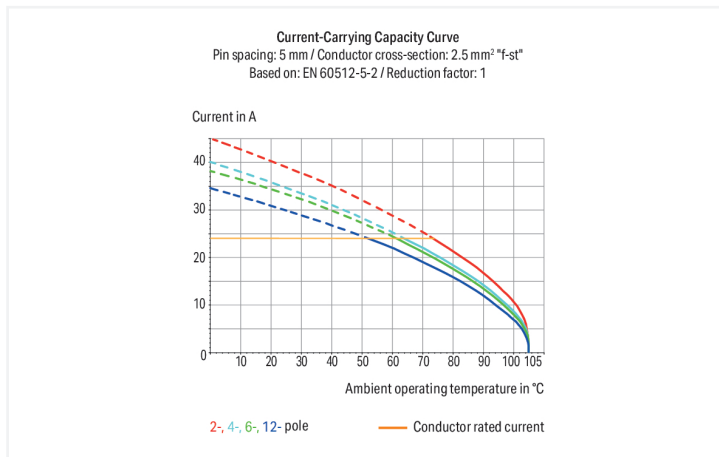
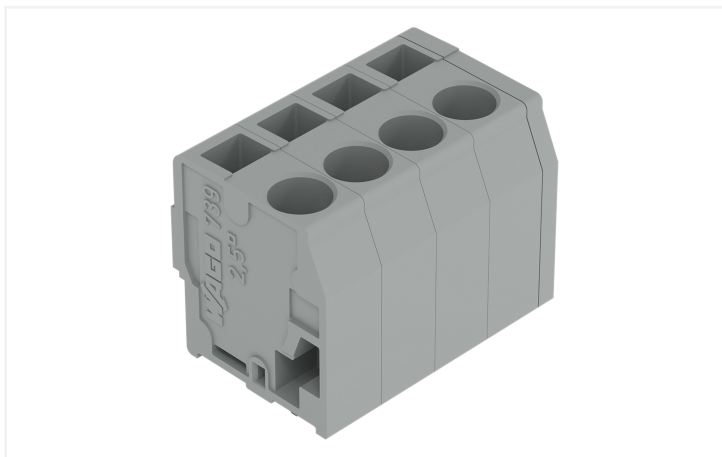

Color: ■ red

Similar to illustration

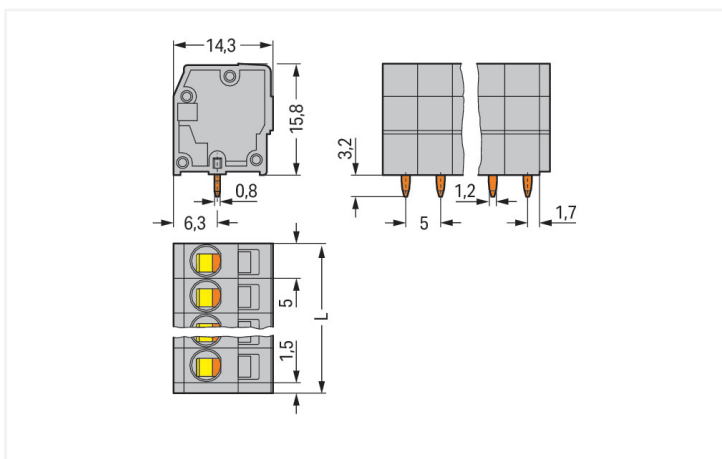

Dimensions in mm

L = (pole no. - 1) x pin spacing + 5 mm + 1.5 mm

## PCB terminal block, 739 Series, operating tool

This PCB terminal block (item number 739-117/000-005) is designed for quick and simple connections. It is a universal connector that can be used almost anywhere, e.g., as a pluggable PCB connector, panel feedthrough header, connector for rail-mount terminal blocks, or a floating connector for different mounting methods. Conductors should only be connected to this PCB terminal block if their strip length is between 8 and 9 mm. This product features one conductor terminal and utilizes CAGE CLAMP®. Our CAGE CLAMP® connection provides a proven and maintenance-free way to connect all types of conductors. You do not need to prepare the conductor in any way, such as crimping ferrules. Dimensions: (86.5 x 19 x 14.3) mm (width x height x depth). This PCB terminal block is suitable for conductor cross sections ranging from 0.08 mm<sup>2</sup> to 2.5 mm<sup>2</sup>.

Tin is used for coating the contact surfaces. An operating tool is used to operate this PCB terminal block. THT is used to assemble the PCB terminal block. The conductor is designed to be inserted into the board at an angle of 90°..

## Notes

Variants:	Other pole numbers Other colors Mixed-color PCB connector strips Direct marking Other versions (or variants) can be requested from WAGO Sales or configured at <a href="https://configurator.wago.com/">https://configurator.wago.com/</a> .
-----------	--

## Electrical data

Ratings per	IEC/EN 60664-1			Approvals per	UL 1059		
Overvoltage category	III	III	II	Use group	B	C	D
Pollution degree	3	2	2	Rated voltage	300 V	-	300 V
Nominal voltage	320 V	320 V	630 V	Rated current	20 A	-	10 A
Rated impulse withstand voltage	4 kV	4 kV	4 kV				
Rated current	24 A	24 A	24 A				

Approvals per	CSA		
Use group	B	C	D
Rated voltage	300 V	-	300 V
Rated current	12 A	-	10 A

## Connection Data

Clamping units	17	<b>Connection 1</b>	
Total number of potentials	17	Connection technology	CAGE CLAMP®
Number of connection types	1	Actuation type	Operating tool
Number of levels	1	Solid conductor	0.08 ... 2.5 mm <sup>2</sup> / 28 ... 14 AWG
		Fine-stranded conductor	0.08 ... 2.5 mm <sup>2</sup> / 28 ... 12 AWG
		Fine-stranded conductor; with insulated ferrule	0.25 ... 1.5 mm <sup>2</sup>
		Fine-stranded conductor; with uninsulated ferrule	0.25 ... 2.5 mm <sup>2</sup>
		Note (conductor cross-section)	12 AWG: THHN, THWN
		Strip length	8 ... 9 mm / 0.31 ... 0.35 inches
		Conductor connection direction to PCB	90 °
		Pole number	17

## Physical data

Pin spacing	5 mm / 0.197 inches
Width	86.5 mm / 3.406 inches
Height	19 mm / 0.748 inches
Height from the surface	15.8 mm / 0.622 inches
Depth	14.3 mm / 0.563 inches
Solder pin length	3.2 mm
Solder pin dimensions	0.8 x 1.2 mm
Drilled hole diameter with tolerance	1.6 (+0.1) mm

### PCB contact

PCB contact	THT
Solder pin arrangement	over the entire terminal strip (in-line)
Number of solder pins per potential	1

### Material data

Note (material data)	<a href="#">Information on material specifications can be found here</a>
Color	red
Material group	I
Insulation material (main housing)	Polyamide (PA66)
Flammability class per UL94	V0
Clamping spring material	Chrome-nickel spring steel (CrNi)
Contact material	Electrolytic copper (E <sub>Cu</sub> )
Contact Plating	Tin
Fire load	0.33 MJ
Weight	19.7 g

### Environmental requirements

Limit temperature range	-60 ... +105 °C
-------------------------	-----------------

### Commercial data

PU (SPU)	40 (10) pcs
Packaging type	Box
Country of origin	CH
GTIN	4055143915540
Customs tariff number	85369010000

### Product Classification

UNSPSC	39121409
ETIM 9.0	EC002643
ETIM 10.0	EC002643
ECCN	NO US CLASSIFICATION

### Environmental Product Compliance

RoHS Compliance Status	Compliant, No Exemption
------------------------	-------------------------

### Approvals / Certificates

#### General approvals



Approval	Standard	Certificate Name
CSA DEKRA Certification B.V.	C22.2 No. 158	1711139
UL Underwriters Laboratories Inc.	UL 1059	E45172

## Downloads

## Environmental Product Compliance

## Compliance Search

Environmental Product  
Compliance  
739-117/000-005



## Documentation

## Additional Information

Technical Section

03.04.2019

pdf

2027.26 KB



## CAD/CAE-Data

## CAD data

2D/3D Models  
739-117/000-005



## PCB Design

Symbol and Footprint  
via SamacSys  
739-117/000-005



Symbol and Footprint  
via Ultra Librarian  
739-117/000-005



## 1 Compatible Products

## 1.1 Optional Accessories

## 1.1.1 Ferrule

## 1.1.1.1 Ferrule



## Item No.: 216-101

Ferrule; Sleeve for 0.5 mm<sup>2</sup> / AWG 22; un-  
insulated; electro-tin plated; silver-colo-  
red



## Item No.: 216-102

Ferrule; Sleeve for 0.75 mm<sup>2</sup> / AWG 20;  
uninsulated; electro-tin plated; silver-co-  
lored

## Installation Notes

## Conductor termination

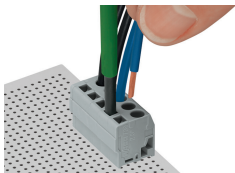

Inserting a conductor parallel to screwdr-  
iver actuation – 739 Series.