

## Data Sheet | Item Number: 771-8992/205-803

pre-assembled connecting cable; Eca; Plug/open-ended; 2-pole; Cod. B; Control cable 2 x 1.0 mm<sup>2</sup>; 8 m; 1,00 mm<sup>2</sup>; gray

<https://www.wago.com/771-8992/205-803>

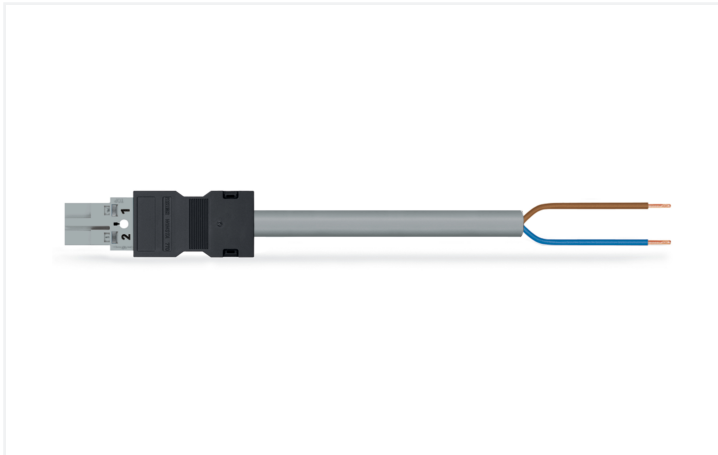

Color: ■ gray

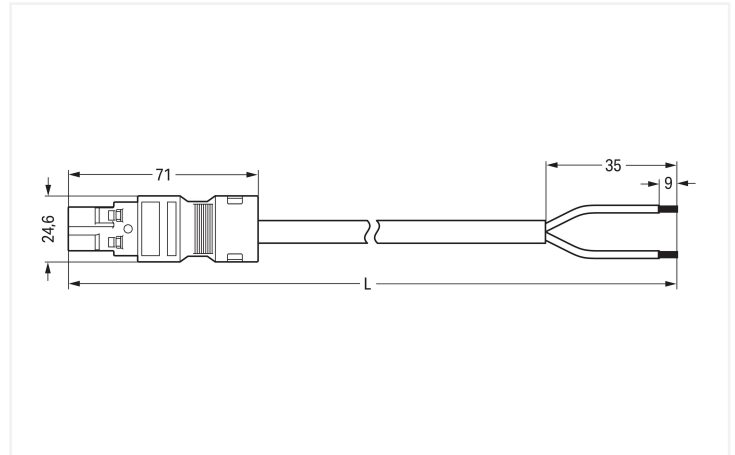

Dimensions in mm

### Cable assembly WINSTA® MIDI 2-pole

For signal and power transmission: The WINSTA® MIDI cable assembly 2-pole. The pluggable installation connectors with spring pressure connection technology work completely without screw connections. They allow flexible, error-free installation in numerous applications. For greater protection in electrical installations, the pluggable installation connector is provided with mechanical protection against mismatching. The pluggable installation connector is protected in accordance with protection type IP20 (When mated: IP2xC (These compact connectors are not designed for use in open, easily accessible areas!)). This means that users' fingers will never come into contact with electrified contact elements. Solutions like the WINSTA® MIDI pluggable installation connectors with B coding are suitable for applications involving process control, such as for lighting or within data networks. WINSTA® MIDI with Push-in CAGE CLAMP® spring pressure connection technology is used in can be found in a variety of projects you can use for quick, easy and maximally flexible installation. Building safety must be ensured at all times, even after the electrical installation stage. The mandatory safety requirements in connection with EU CPR are met by this product through fire class E.

### Pluggable connections instead of screw connections – cable assemblies from WAGO

A plug and a free end are available. The WINSTA® Pluggable Connection System is perfectly tailored to the very strict requirements of building installation. It makes electrical installation pluggable, and consequently more efficient, more reliable, and error-free. Use of this pre-assembled system decreases assembly times and installation errors at the construction site. Now you can also reduce installation costs without compromising quality and safety: with protection type IP20 eliminates the need for servicing and prevents unnecessary downtime.

- effective protection against mismatching
- pre-assembled versions
- with B coding for controllers such as lighting fixtures and sun blinds
- exact dimensions
- fast, secure installation

### Notes

Note

Cables with a different fire class can be found in the eShop.

Variants:

Other pole markings

Other versions (or variants) can be requested from WAGO Sales or configured at <https://configurator.wago.com/>.

## Electrical data

Ratings per	IEC/EN 60664-1		
Overvoltage category	III	III	II
Pollution degree	3	2	2
Nominal voltage	250 V	-	-
Rated impulse withstand voltage	4 kV	-	-
Rated current	10 A	-	-

## General information

Note on contact resistance	approx. 1 mΩ of contact resistance approx. 0.25 mΩ contact transition plug/ socket
----------------------------	--

## Connection Data

Total number of potentials	2
Conductor preparation	ultrasonically tip-bonded

## Connection 1

Strip length	9 mm / 0.35 inches
Pole number	2
Wire cross-section	1 mm <sup>2</sup>
Strip length (outer insulation)	35 mm
Connection type	Plug - free end

## Physical data

Pin spacing	10 mm / 0.394 inches
Width	24.6 mm / 0.969 inches
Height	15.9 mm / 0.626 inches
Total length	8 m

## Mechanical data

Use	Control technology
Coding	B
Variable coding	No
Marking	1 2
Potential marking	1 2
Mating force of a plug-in connection	approx. 20 ... 70 N (depending on pole number)
Retention force of a plug-in connection	when locked: > 80N
Unmating force of a plug-in connection	when unlocked: approx. 20 ... 70 N (depending on pole number)
Number of mating cycles	200, without resistive load
Connection type	Plug - free end
Type of pre-assembled cable	Connecting cable
Cable type	Control line 2x1
Protection type	IP20; When mated: IP2xC (These compact connectors are not designed for use in open, easily accessible areas!)

## Plug-in connection

Mismating protection	Yes
Note on mismating protection	All <i>WINSTA</i> ® components are 100% protected against mismating when: a.) plugging different numbers of poles b.) plugging while rotated 180 c.) plugging while laterally staggered d.) plugging one pole
Locking lever	Can be retrofitted
Locking of plug-in connection	Locking lever
Note on locking system	All connectors for mounted installations (snap-in versions for lighting fixtures or devices, all types of PCB and distribution connectors) are factory-equipped with locking levers to ensure plugs and sockets are securely locked. Additional locking levers are only required for flying leads (plug/socket).

### Material data

Note (material data)	<a href="#">Information on material specifications can be found here</a>
Color	gray
Insulation material (main housing)	Polyamide (PA66)
Fire class per EN 50575	E <sub>ca</sub>
Contact material	Copper or copper alloy; surface-treated
Contact Plating	Tin
Fire load	0.32 MJ
Connector color	gray
Strain relief color	black
Sheathed cable color	gray
Printing color of sheathed cable	black
Halogen-free	No
Silicon-free	Yes
Sheath material	PVC
Rubber cable	No
Weight	387.2 g
Copper weight of the raw cable	0.0192 kg/m

### Environmental requirements

Processing temperature	-5 ... +40 °C
Continuous operating temperature	-35 ... +85 °C
Note on continuous operating temperature	Cable for temperatures ≤ 70 °C (including halogen-free) Insulating parts for temperatures ≤ 105 °C

### Commercial data

PU (SPU)	1 pcs
Packaging type	unpacked
Country of origin	DE
GTIN	4055143486552
Customs tariff number	85444290900

### Product Classification

UNSPSC	26121629
eCl@ss 10.0	27-44-06-04
eCl@ss 9.0	27-44-06-04
ETIM 9.0	EC002587
ETIM 10.0	EC002587
ECCN	NO US CLASSIFICATION

### Environmental Product Compliance

RoHS Compliance Status	Compliant, No Exemption
------------------------	-------------------------

**Downloads**

**Environmental Product Compliance**

Compliance Search			
Environmental Product Compliance			↓
771-8992/205-803			

**Documentation**

Bid Text			
771-8992/205-803	19.02.2019	xml 2.99 KB	↓
771-8992/205-803	02.06.2015	doc 26.00 KB	↓

**CAD/CAE-Data**

CAE data	
EPLAN Data Portal	↓
771-8992/205-803	

**1 Compatible Products**

**1.1 Required Accessories**

**1.1.1 Locking system**

**1.1.1.1 Locking system**

<p><b>Item No.: 770-101</b> Locking lever; for flying leads; for manual operation; black</p>	<p><b>Item No.: 770-121</b> Locking lever; for flying leads; for manual operation; white</p>	<p><b>Item No.: 770-111</b> Locking lever; for flying leads; for tool operation; black</p>	<p><b>Item No.: 770-131</b> Locking lever; for flying leads; for tool operation; white</p>

**1.2 Optional Accessories**

**1.2.1 Cover**

**1.2.1.1 Cover**

<p><b>Item No.: 770-360</b> Lockout cap; for plugs; 5-pole; separable; yellow</p>	<p><b>Item No.: 897-2003</b> Protective cap; Type2; for sockets and plugs; PVC; red</p>

## 1.2.2 Installation

### 1.2.2.1 Mounting accessories



**Item No.: 770-310**

Mounting carrier; 2- to 5-pole; for flying leads; black

## 1.2.3 Marking

### 1.2.3.1 Marking strip



**Item No.: 210-334**

Marking strips; as a DIN A4 sheet; Strip width 5 mm; Strip length 182 mm; plain; Self-adhesive; white