

Data Sheet | Item Number: 771-6993/206-802

pre-assembled connecting cable; Eca; Plug/open-ended; 3-pole; Cod. A; H05VV-F
3G 1.5 mm²; 8 m; 1,50 mm²; white

<https://www.wago.com/771-6993/206-802>

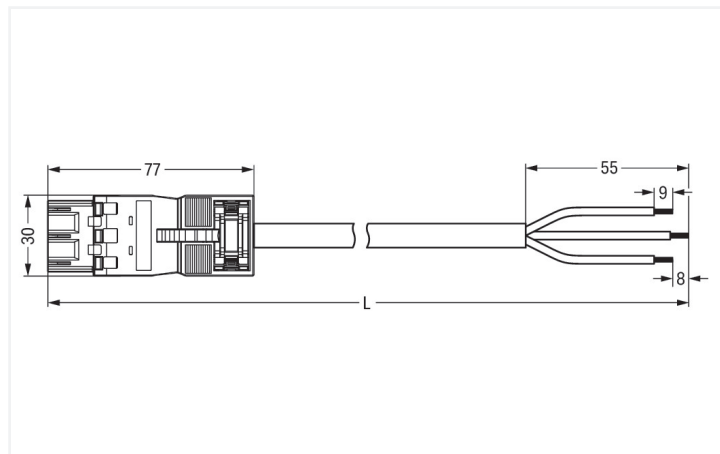

Color: ■ white

Similar to illustration

Dimensions in mm

Cable assembly WINSTA® MIDI with strain relief

The WINSTA® MIDI cable assembly A coding is the pluggable solution for your application in control cabinets, on PCBs or for lighting connections. The pluggable installation connectors with spring pressure connection technology function entirely without screw connections. They allow resource-efficient, error-free installation in a large number of possible uses. The color coding and mechanical coding of the pluggable installation connector ensure error-free installation of the individual components – including protection against mismatching. General mains applications for almost any domain of use can be realised with WINSTA® MIDI pluggable installation connectors with A coding. The WINSTA® MIDI Pluggable Connection System with Push-in CAGE CLAMP® spring pressure connection technology facilitates safe electrification. Thanks to the integrated test slot, it is possible to check connections even when they are plugged in. That saves time and reduces installation labor and costs. This product meets all the mandatory fire protection requirements of fire class E; thus it can be used in areas where fire safety is relevant.

Pluggable connections instead of screw connections – cable assemblies from WAGO

The cable assembly is equipped with a plug and a free end. The WINSTA® Pluggable Connection System allows pluggable electrical installation. This saves time, lowers costs, and reduces the need for servicing. Choose quality and durability – with protection against mismatching from WAGO makes the electrical installation of electrical components visibly easier.

- pluggable installation connectors with protection against mismatching
- pre-assembled versions
- suitable for any application
- flexible installation to save space
- convenient installation and commissioning

Notes

Note

Cables with a different fire class can be found in the eShop.

Electrical data

Ratings per	IEC/EN 60664-1		
Overvoltage category	III	III	II
Pollution degree	3	2	2
Nominal voltage	250 V	-	-
Rated impulse withstand voltage	4 kV	-	-
Rated current	16 A	-	-

General information

Note on contact resistance	approx. 1 mΩ of contact resistance approx. 0.25 mΩ contact transition plug/ socket
----------------------------	--

Connection data

Total number of potentials	3
PE function	Preceding PE contact
Conductor preparation	ultrasonically tip-bonded

Connection 1

Strip length	9 mm / 0.35 inches
Pole number	3
Wire cross-section	1.5 mm ²
Strip length (outer insulation)	55 mm
Connection type	Plug - free end

Physical data

Pin spacing	10 mm / 0.394 inches
Width	30 mm / 1.181 inches
Height	12.9 mm / 0.508 inches
Total length	8 m

Mechanical data

Use	General mains applications
Coding	A
Variable coding	Yes
Marking	L ⊕ N
Potential marking	L ⊕ N
Mating force of a plug-in connection	approx. 20 ... 70 N (depending on pole number)
Retention force of a plug-in connection	when locked: > 80N
Unmating force of a plug-in connection	when unlocked: approx. 20 ... 70 N (depending on pole number)
Number of mating cycles	200, without resistive load
Connection type	Plug - free end
Type of pre-assembled cable	Connecting cable
Cable type	H05VV-F 3G1.5
Protection type	IP2XD; When mated: IP2xC (These compact connectors are not designed for use in open, easily accessible areas!)

Plug-in connection

Mismating protection	Yes
Note on mismating protection	All <i>WINSTA</i> ® components are 100% protected against mismating when: a.) plugging different numbers of poles b.) plugging while rotated 180 c.) plugging while laterally staggered d.) plugging one pole
Locking lever	Can be retrofitted
Locking of plug-in connection	Locking lever
Note on locking system	All connectors for mounted installations (snap-in versions for lighting fixtures or devices, all types of PCB and distribution connectors) are factory-equipped with locking levers to ensure plugs and sockets are securely locked. Additional locking levers are only required for flying leads (plug/socket).

Material data

Note (material data)	Information on material specifications can be found here
Color	white
Insulation material (main housing)	Polyamide (PA66)
Fire class per EN 50575	E _{ca}
Contact material	Copper or copper alloy; surface-treated
Contact Plating	Tin
Fire load	240.024 MJ
Connector color	white
Strain relief color	white
Sheathed cable color	white
Printing color of sheathed cable	black
Halogen-free	No
Silicon-free	Yes
Sheath material	PVC
Rubber cable	No
Weight	812.9 g
Copper weight of the raw cable	0.043 kg/m

Environmental requirements

Processing temperature	-5 ... +40 °C
Continuous operating temperature	-35 ... +85 °C
Note on continuous operating temperature	Cable for temperatures ≤ 70 °C (including halogen-free) Insulating parts for temperatures ≤ 105 °C

Commercial data

PU (SPU)	1 pcs
Packaging type	unpacked
Country of origin	DE
GTIN	4055143489423
Customs tariff number	85444290900

Product Classification

UNSPSC	26121629
eCl@ss 10.0	27-44-06-04
eCl@ss 9.0	27-44-06-04
ETIM 9.0	EC002587
ETIM 10.0	EC002587
ECCN	NO US CLASSIFICATION

Environmental Product Compliance

RoHS Compliance Status	Compliant, No Exemption
------------------------	-------------------------

Approvals / Certificates

General approvals



Approval	Standard	Certificate Name
CCA DEKRA Certification B.V.	IEC 61535	NTR NL-7355
KEMA/KEUR DEKRA Certification B.V.	EN 61535	71-123834

Declarations of conformity and manufacturer's declarations

Approval	Standard	Certificate Name
EU-Declaration of Confor- mity WAGO GmbH & Co. KG	-	-
UK-Declaration of Confor- mity WAGO GmbH & Co. KG	-	-

Downloads

Environmental Product Compliance

Compliance Search

Environmental Product Compliance 771-6993/206-802	↓
---	---

Documentation

Bid Text

771-6993/206-802	19.02.2019	xml 3.04 KB	↓
771-6993/206-802	14.01.2015	doc 26.50 KB	↓

CAD/CAE-Data

CAE data

EPLAN Data Portal 771-6993/206-802	↓
WSCAD Universe 771-6993/206-802	↓

1 Compatible Products

1.1 Required Accessories

1.1.1 Locking system

1.1.1.1 Locking system



[Item No.: 770-101](#)
Locking lever; for flying leads; for manual operation; black

[Item No.: 770-121](#)
Locking lever; for flying leads; for manual operation; white

[Item No.: 770-111](#)
Locking lever; for flying leads; for tool operation; black

[Item No.: 770-131](#)
Locking lever; for flying leads; for tool operation; white

1.2 Optional Accessories

1.2.1 Cover

1.2.1.1 Cover



Item No.: 770-360

Lockout cap; for plugs; 5-pole; separable;
yellow

1.2.2 Installation

1.2.2.1 Mounting accessories



Item No.: 770-310

Mounting carrier; 2- to 5-pole; for flying
leads; black

1.2.3 Marking

1.2.3.1 Marking strip



Item No.: 210-334

Marking strips; as a DIN A4 sheet; Strip
width 5 mm; Strip length 182 mm; plain;
Self-adhesive; white