

Wilo-Control CC-HVAC (CC, CC-FC, CCe)



- de** Einbau- und Betriebsanleitung
- en** Installation and operating instructions
- fr** Notice de montage et de mise en service
- nl** Inbouw- en bedieningsvoorschriften

Fig. 1a:

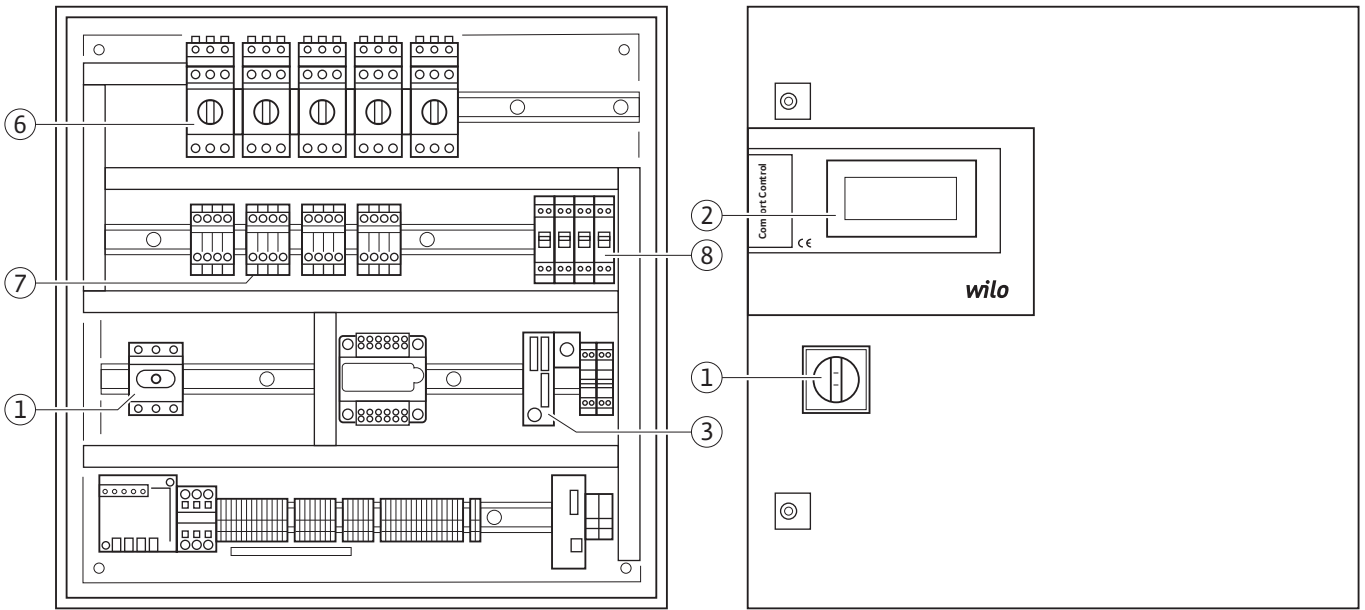

Fig. 1b:

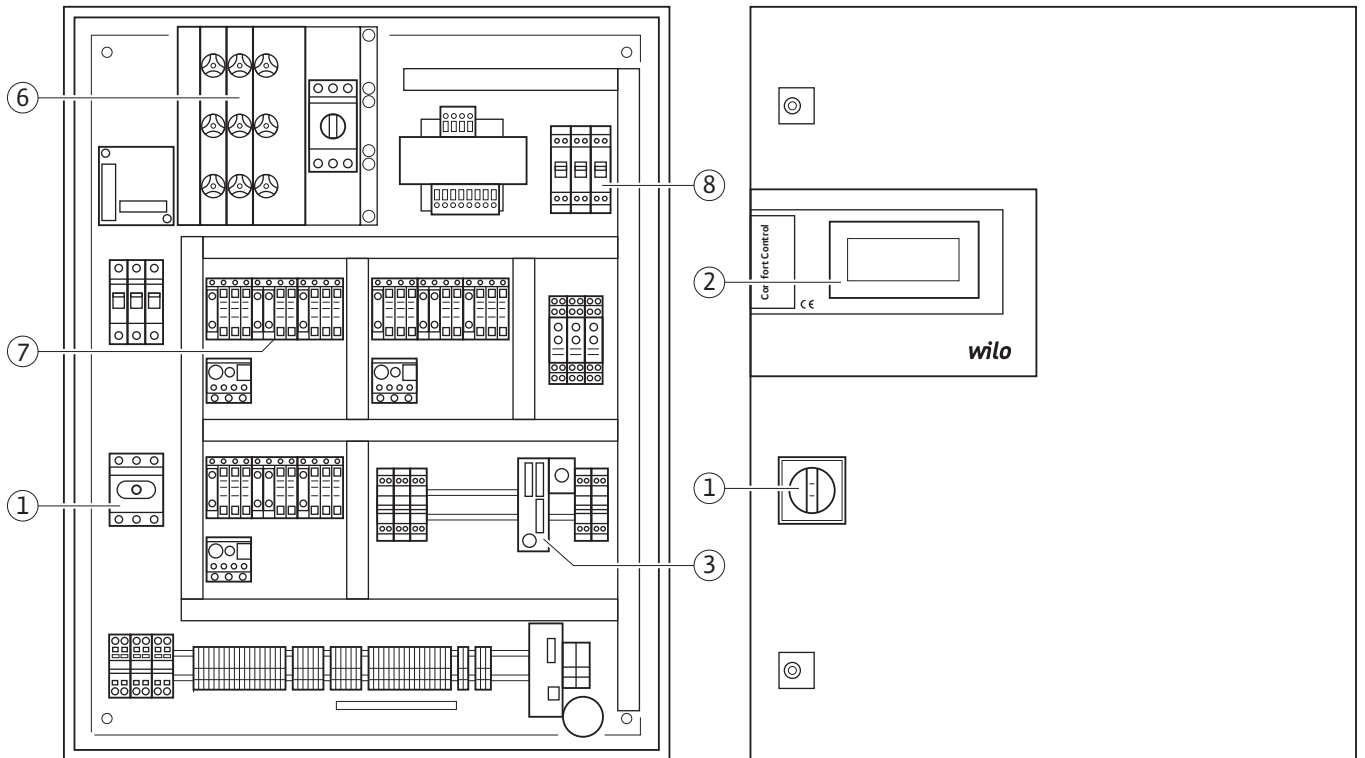

Fig. 1c:

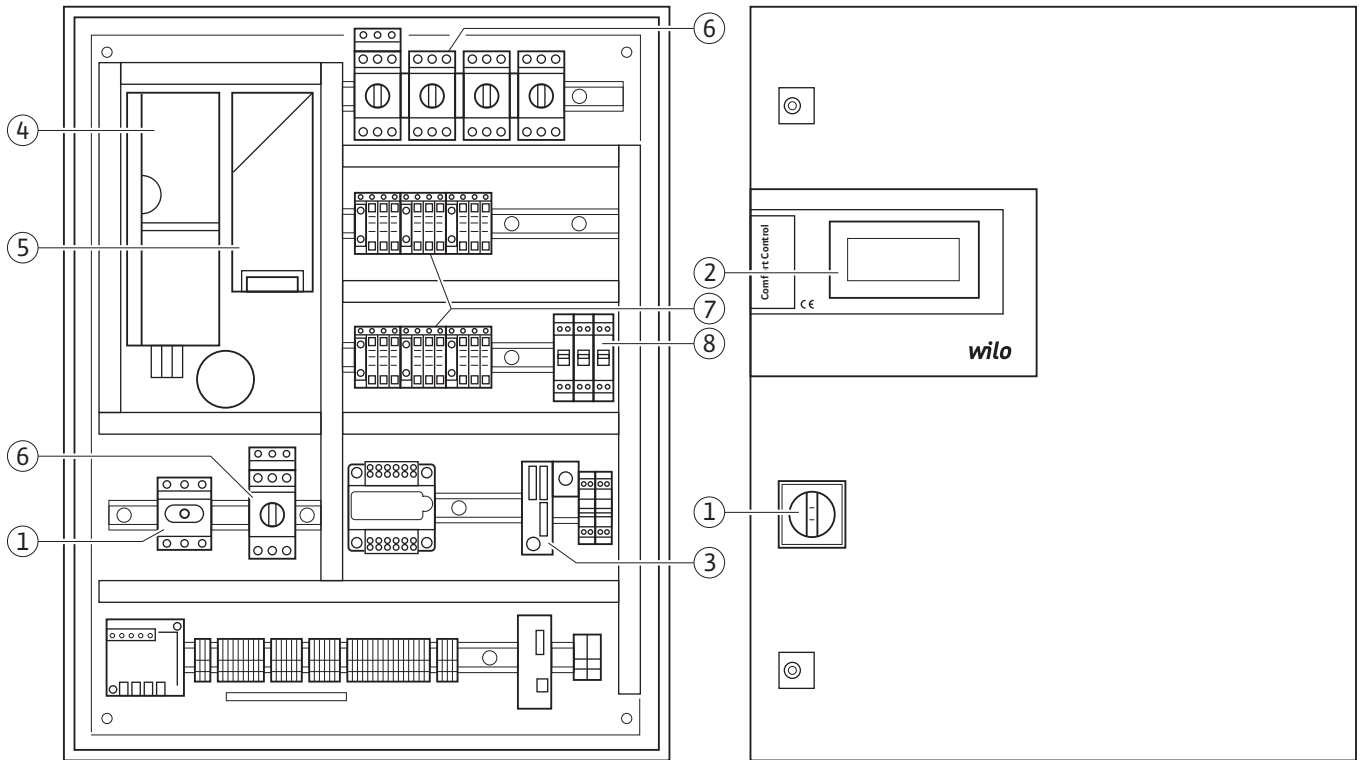

Fig. 1d:

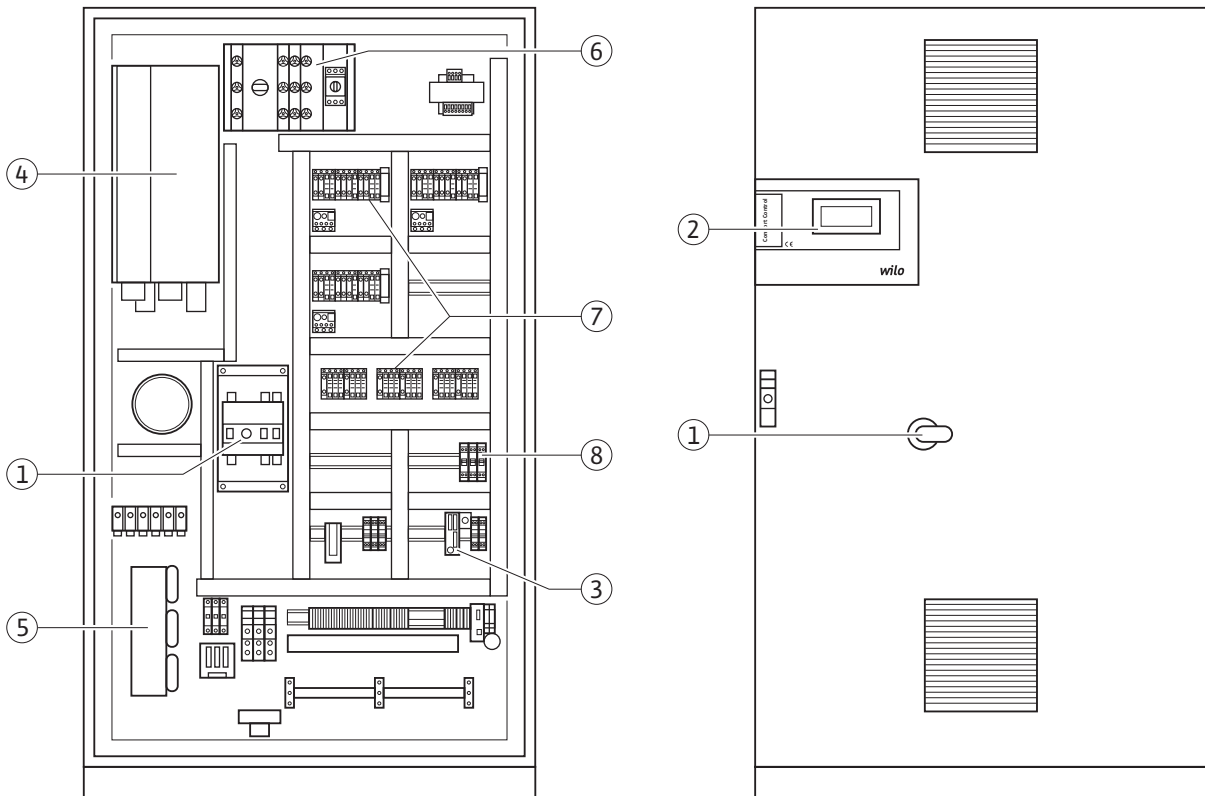

Fig. 1e:

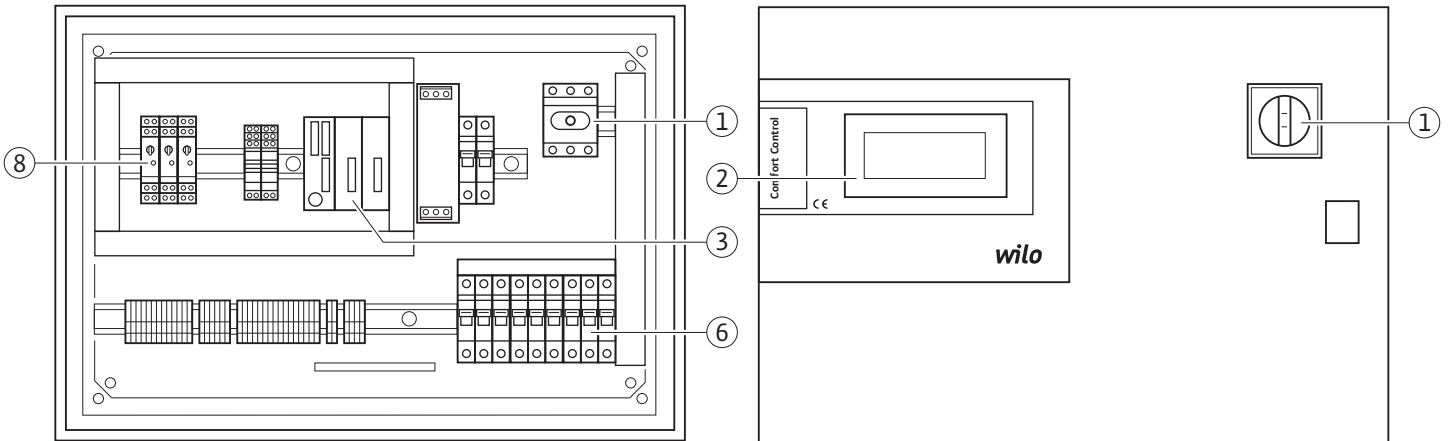

Fig. 2:

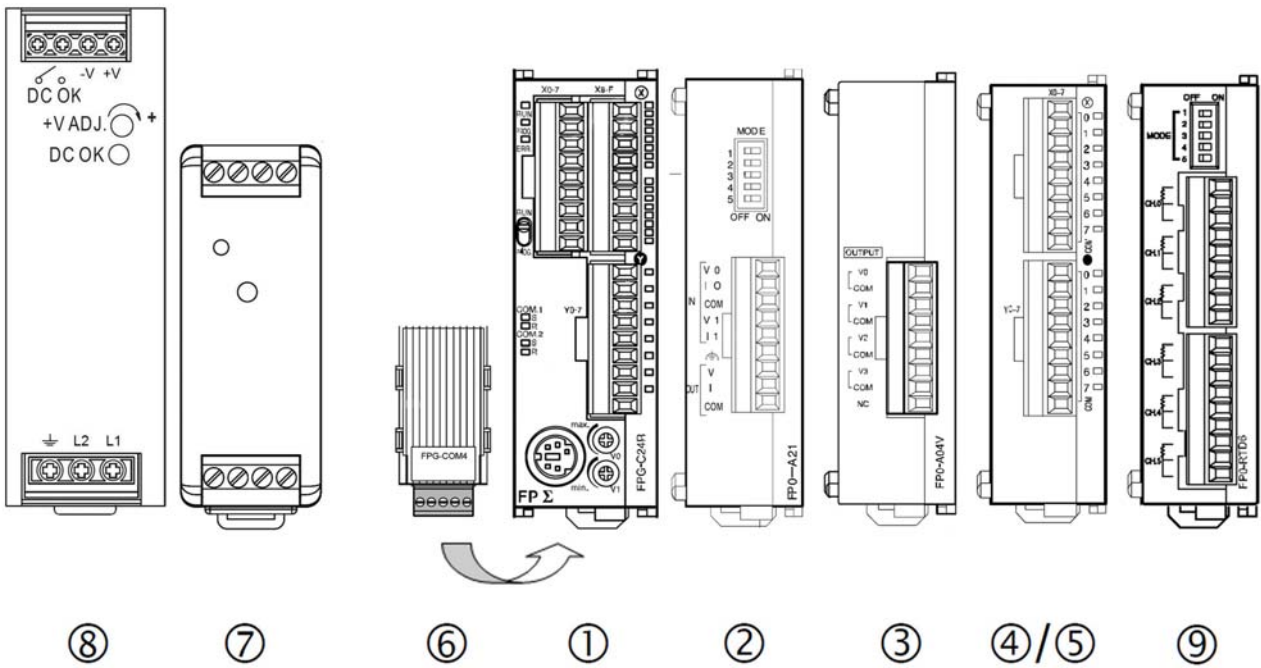

Fig. 3:

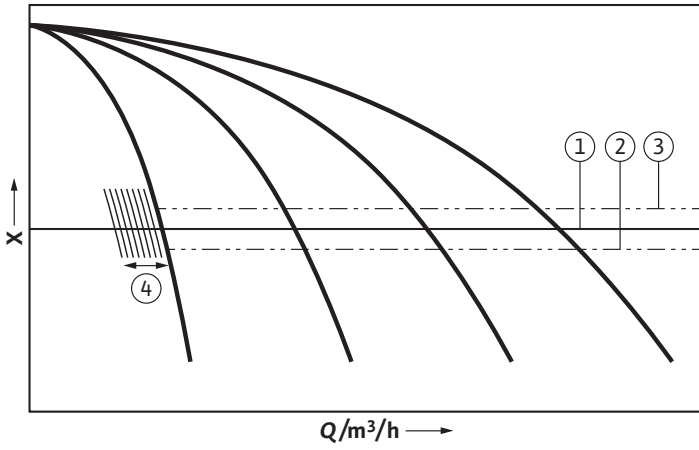

Fig. 4:

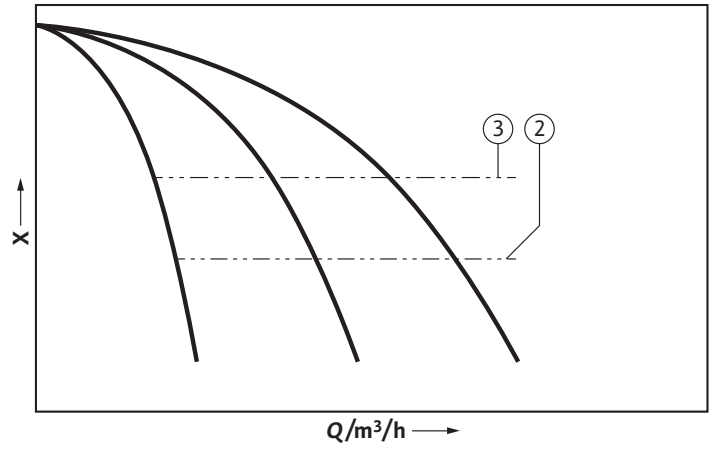

Fig. 5a:

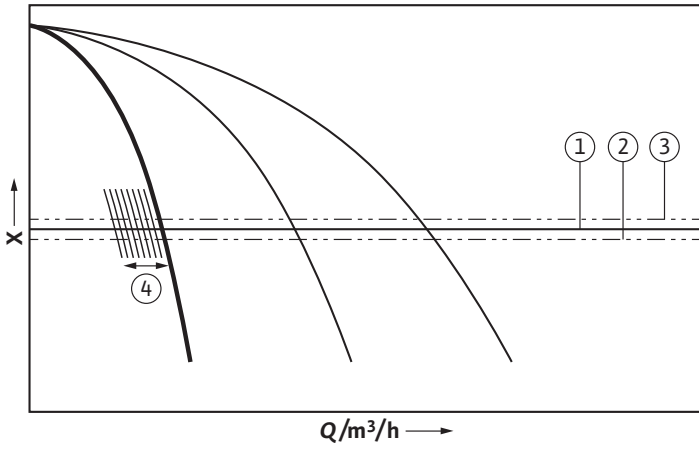

Fig. 5b:

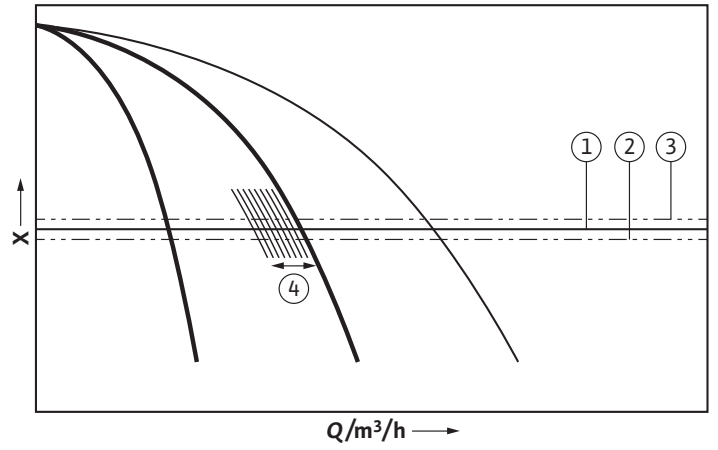

Fig. 5c:

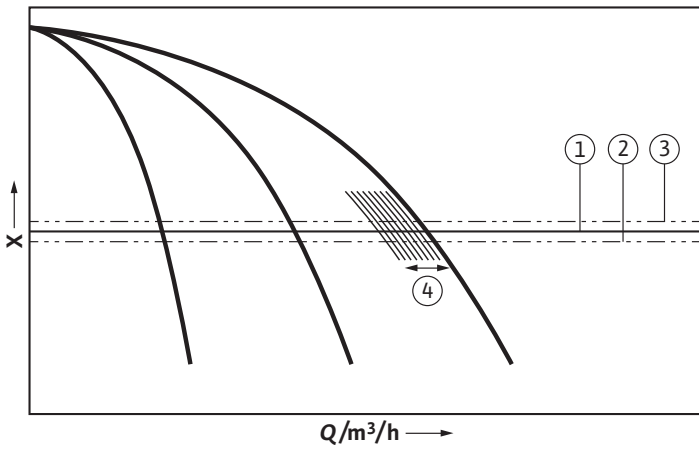

Fig. 6:

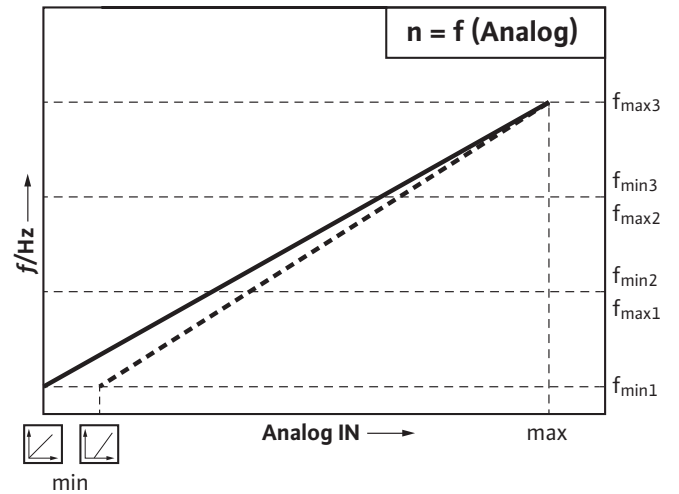

Fig. 7:

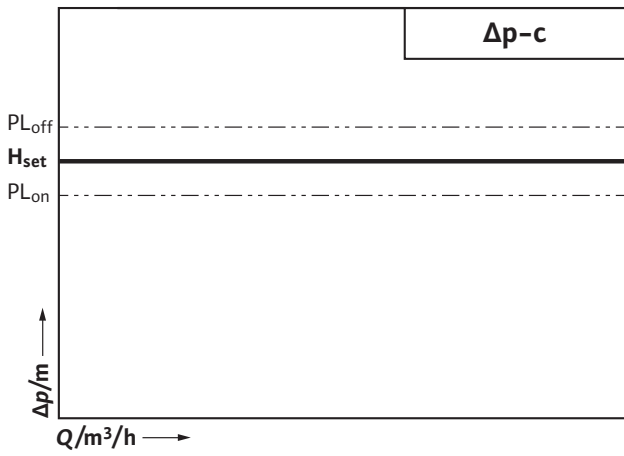

Fig. 8:

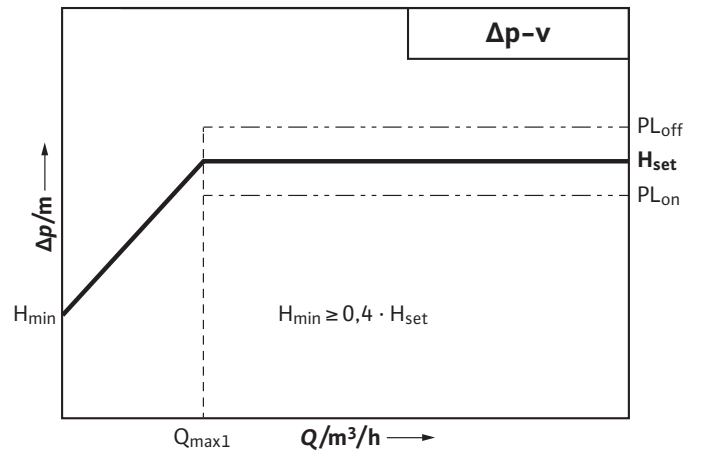

Fig. 9:

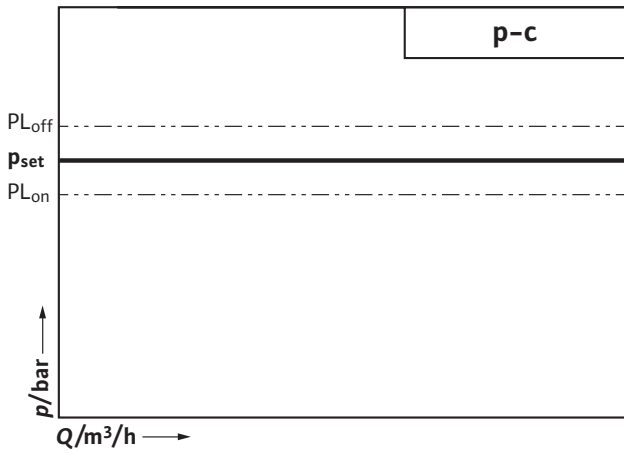

Fig. 10:

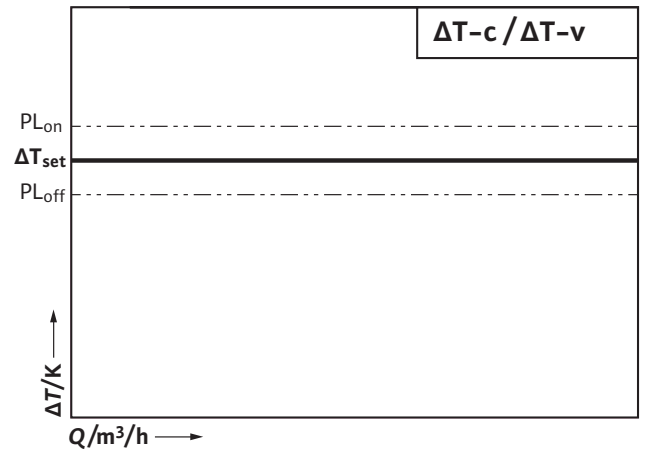

Fig. 11:

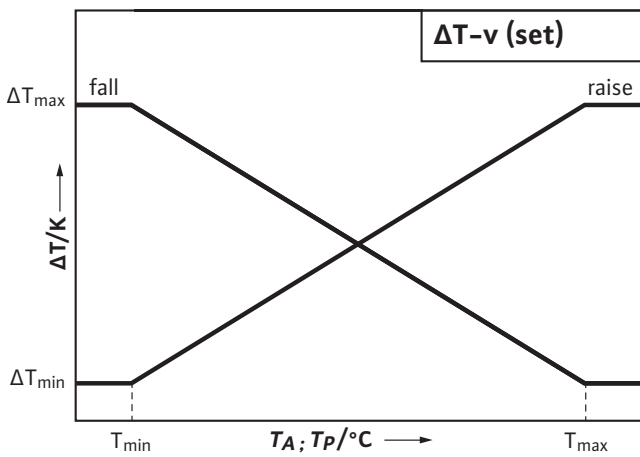

Fig. 12:

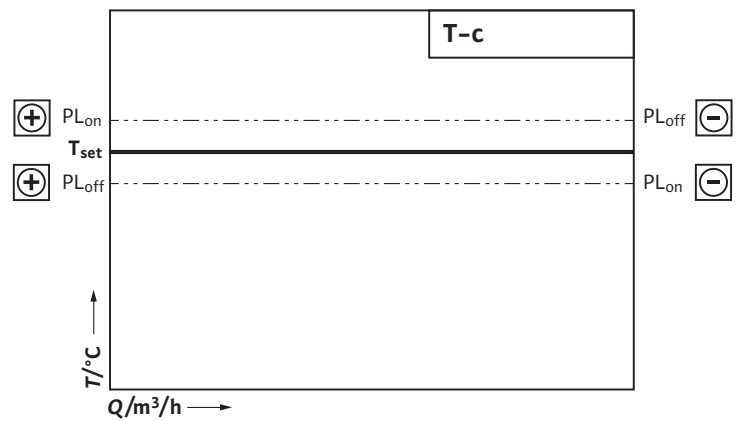
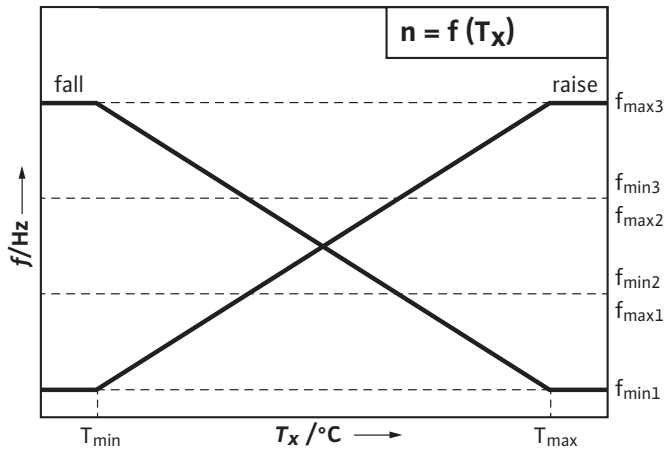

Fig. 13:



1	General information	61
2	Safety	61
2.1	Symbols and signal words in the operating instructions	61
2.2	Personnel qualifications.....	62
2.3	Danger in the event of non-observance of the safety instructions	62
2.4	Safety consciousness on the job.....	62
2.5	Safety instructions for the operator	62
2.6	Safety instructions for installation and maintenance work	63
2.7	Unauthorised modification and manufacture of spare parts.....	63
2.8	Improper use	63
3	Transport and interim storage	63
4	Intended use	63
5	Product information.....	64
5.1	Type key	64
5.2	Technical data	64
5.3	Scope of delivery	64
5.4	Accessories.....	65
6	Description and function	65
6.1	Description of the product	65
6.1.1	Function description	65
6.1.2	Set-up of the control device	66
6.2	Function and operation	67
6.2.1	Switchgear operating modes	67
6.2.2	Control modes.....	71
6.2.3	Motor protection	72
6.2.4	Operation of the switchgear	73
6.2.5	Menu structure.....	77
6.2.6	User levels	80
7	Installation and electrical connection.....	107
7.1	Installation.....	107
7.2	Electrical connection.....	107
8	Commissioning	113
8.1	Factory setting.....	113
8.2	Checking the motor direction of rotation	113
8.3	Adjusting the motor protection.....	114
8.4	Signal transmitters and optional modules	114
9	Maintenance.....	114
10	Faults, causes and remedies.....	115
10.1	Fault display and acknowledgement.....	115
10.2	History memory for faults	115
11	Spare parts	116
12	Disposal	116

1 General information

About this document

The language of the original operating instructions is German. All other languages of these instructions are translations of the original operating instructions.

These installation and operating instructions are an integral part of the product. They must be kept readily available at the place where the product is installed. Strict adherence to these instructions is a precondition for the proper use and correct operation of the product.

These installation and operating instructions correspond to the relevant version of the product and the underlying safety standards valid at the time of going to print.

EC declaration of conformity:

A copy of the EC declaration of conformity is a component of these operating instructions.

If a technical modification is made on the designs named there without our agreement or the declarations made in the installation and operating instructions on product/personnel safety are not observed, this declaration loses its validity.

2 Safety

These operating instructions contain basic information which must be adhered to during installation, operation and maintenance. For this reason, these operating instructions must, without fail, be read by the service technician and the responsible specialist/operator before installation and commissioning.

It is not only the general safety instructions listed under the main point "safety" that must be adhered to but also the special safety instructions with danger symbols included under the following main points.

2.1 Symbols and signal words in the operating instructions

Symbols



General danger symbol



Danger due to electrical voltage



NOTE

Signal words

DANGER!

Acutely dangerous situation.

Non-observance results in death or the most serious of injuries.

WARNING!

The user can suffer (serious) injuries. 'Warning' implies that (serious) injury to persons is probable if this information is disregarded.

CAUTION!

There is a risk of damaging the product/unit. 'Caution' implies that damage to the product is likely if this information is disregarded.

NOTE:

Useful information on handling the product. It draws attention to possible problems.

Information that appears directly on the product, such as

- Direction of rotation arrow
- Connection markings
- Rating plate
- Warning sticker

must be strictly complied with and kept in legible condition.

2.2 Personnel qualifications

The installation, operating and maintenance personnel must have the appropriate qualifications for this work. Area of responsibility, terms of reference and monitoring of the personnel are to be ensured by the operator. If the personnel are not in possession of the necessary knowledge, they are to be trained and instructed. This can be accomplished, if necessary, by the manufacturer of the product at the request of the operator.

2.3 Danger in the event of non-observance of the safety instructions

Non-observance of the safety instructions can result in risk of injury to persons and damage to the environment and the product/unit. Non-observance of the safety instructions results in the loss of any claims to damages.

In detail, non-observance can, for example, result in the following risks:

- Danger to persons due to electrical, mechanical and bacteriological factors
- Damage to the environment due to leakage of hazardous materials
- Property damage
- Failure of important product/unit functions
- Failure of required maintenance and repair procedures

2.4 Safety consciousness on the job



The safety instructions included in these installation and operating instructions, the existing national regulations for accident prevention together with any internal working, operating and safety regulations of the operator are to be complied with.

2.5 Safety instructions for the operator

This appliance is not intended for use by persons (including children) with reduced physical, sensory or mental capabilities, or lack of experience and knowledge, unless they have been given supervision or instruction concerning use of the appliance by a person responsible for their safety.

Children should be supervised to ensure that they do not play with the appliance.

- If hot or cold components on the product/unit lead to hazards, local measures must be taken to guard them against touching.
- Guards protecting against touching moving components (such as the coupling) must not be removed whilst the product is in operation.
- Leakages (e.g. from the shaft seal) of hazardous fluids (which are explosive, toxic or hot) must be discharged in such a way that no danger to persons or to the environment arises. National statutory provisions are to be complied with.
- Highly flammable materials are always to be kept at a safe distance from the product.
- Danger from electrical current must be eliminated. Local directives or general directives [e.g. IEC, VDE etc.] and instructions from local energy supply companies must be adhered to.

- 2.6 Safety instructions for installation and maintenance work**
- The operator must ensure that all installation and maintenance work is carried out by authorised and qualified personnel, who are sufficiently informed from their own detailed study of the operating instructions.
- Work on the product/unit must only be carried out when at a standstill. It is mandatory that the procedure described in the installation and operating instructions for shutting down the product/unit be complied with.
- Immediately on conclusion of the work, all safety and protective devices must be put back in position and/or recommissioned.
- 2.7 Unauthorised modification and manufacture of spare parts**
- Unauthorised modification and manufacture of spare parts will impair the safety of the product/personnel and will make void the manufacturer's declarations regarding safety.
- Modifications to the product are only permissible after consultation with the manufacturer. Original spare parts and accessories authorised by the manufacturer ensure safety. The use of other parts will absolve us of liability for consequential events.
- 2.8 Improper use**
- The operating safety of the supplied product is only guaranteed for conventional use in accordance with Section 4 of the operating instructions. The limit values must on no account fall under or exceed those values specified in the catalogue/data sheet.
- 3 Transport and interim storage**
- Immediately after receiving the product: Check the product for transport damage. If transport damage is detected, the necessary steps involving the carrier must be taken within the specified period.
-  **CAUTION! Risk of property damage!**
Incorrect transport and interim storage can cause damage to the product.
- **The switchgear is to be protected against moisture and mechanical damage.**
 - **The switchgear must not be exposed to temperatures outside the range between -10 °C and +50 °C.**
- 4 Intended use**
- Purpose**
- The CC/CCe switchgear is used for automatic, convenient control of single-pump and multi-pump systems.
- Fields of application**
- The fields of application include heating, ventilation and air-conditioning systems in residential buildings, hotels, hospitals and administrative and industrial buildings.
- When used in conjunction with suitable signal transmitters, the pumps offer low-noise and energy-saving operation. The power of the pumps is adapted to the constantly changing requirements in the heating/water-supply system.
-  **CAUTION! Risk of property damage!**
Incorrect use/handling can lead to damage to the product.
- **Intended use includes compliance with this manual.**
 - **Any other use is regarded as non-compliant with the intended use.**

5 Product information

5.1 Type key

The type key consists of the following elements:

Example:	CC-HVAC 4x3.0 FC
CC	Comfort Controller for pumps with fixed speed
CCe	Comfort Controller for electronic pumps
HVAC	Heating, ventilation and air-conditioning systems
4x	Number of pumps
3.0	Max. rated motor power P_2 [kW]
FC	With frequency converter
WM	Wall mounted
BM	Base mounted

Table 1: Type key

5.2 Technical data

Property	Value	Remarks
Mains supply voltage	3~400 V (L1, L2, L3, PE)	
Mains frequency	50/60 Hz	
Control voltage	24 V DC, 230 V AC	
Max. current consumption	See rating plate	
Protection class	IP 54	
Max. fuse protection on mains side	See wiring diagram	
Max. permissible ambient temperature	0 to +40 °C	
Electrical safety	Pollution degree II	

Table 2: Technical data

Please provide all the information on the rating plate when ordering spare parts.

5.3 Scope of delivery

- CC/CCe-HVAC switchgear
- Wiring diagram
- CC/CCe-HVAC installation and operating instructions
- Frequency converter installation and operating instructions (only for CC... FC version)
- Test report in accordance with EN 60204-1

5.4 Accessories

Accessories must be ordered separately:

Accessories	Description
Signalling module	Relay output module for outputting individual operation signals and fault signals
DDC and control module	Input terminal assembly for switching potential-free control contacts
GSM module	GSM module for dialling into GSM networks
GPRS module	Mobile radio module for dialling into GPRS networks
Web server	Controller module for connection to Internet or Ethernet data transmission
Profibus DP communication module	Bus communication module for Profibus DP networks
CANopen communication module	Bus communication module for CANopen networks
LON communication module	Bus communication module for LON networks
ModBus RTU communication module	Bus communication module for ModBus networks (RS485)
BACnet communication module	Bus communication module for BACnet networks (MSTP, IP)
PTC relay	Evaluation relay for connecting PTC resistors (motor monitoring)
Signal converter U/I	Converter for connecting voltage signals (0/2–10V) as actuator input
Switch cabinet air-conditioning	Cooling/heating for switch cabinet
Switch cabinet lighting	Interior lighting for switch cabinet
Socket	Socket in switch cabinet (fused)
Soft starter	Soft starter for pumps
Energy measurement	Module for recording electrical parameters (e.g. energy consumption) for the control device
Buffered power supply unit	Continued power supply to PLC in the event of a mains outage
Mains switching	Assembly for switching to redundant supply network
Redundant actual value measurement	2nd pressure/differential pressure sensor + 2nd analogue input in case of a fault
Level relay	Relay for evaluation of low water electrodes
Overvoltage protection	Equipment for protecting the device and the sensors against overvoltage
Phase failure protection	Phase relay and/or phase lights
Application-specific housing design	Material; protection class; vandalism security; installation location
Master slave operation	2 devices in master/slave mode

Table 3: Accessories

For a detailed list, consult the catalogue/price list.

6 Description and function

For a description of the product, see also fig. 1a to fig. 1e.

6.1 Description of the product

6.1.1 Function description

The Comfort control system, controlled by a programmable logic controller (PLC), is used to control and regulate pump systems with up to 6 single pumps. The relevant controlled variable for a system is controlled according to the load using appropriate signal transmitters. The controller acts on a frequency converter (CC...FC design), which in turn influences the speed of the base-load pump. Adjusting the speed changes the volume flow and thus the rated power of the pump system.

Only the base-load pump is speed-controlled. Non-regulated peak-load pumps are switched on and off automatically according to load requirements, while the base-load pump carries out fine-tuning to the preset setpoint.

On the CCe version, each pump has an (integrated) frequency converter.

6.1.2 Set-up of the control device

The set-up of the control device depends on the power of the pumps that are to be connected, and the version (CC, CC-FC, CCe), see Fig. 1a: CC direct starting
 Fig. 1b: CC star delta starting
 Fig. 1c: CC-FC direct starting
 Fig. 1d: CC-FC star delta starting
 Fig. 1e: CCe

It consists of the following main components:

- **Main switch:**
Switches the switchgear on/off (item 1).
- **Touch display:**
Display for operating data (see menus) and the operating status by changing the colour of the backlight. Menu selection and parameter input possible using touch sensitive surface (item 2).
- **Programmable logic controller:**
Modular design PLC with power supply unit. The relevant configuration (see below) depends on the system (item 3).

Component	No.	Wilо-CC...FC			Wilо-CC...	Wilо-CCe...	
		1-3 pumps	4-5 pumps	6 pumps	1-6 pumps	1-4 pumps	5-6 pumps
Central unit (CPU)	(1)	✓	✓	✓	✓	✓	✓
Analogue module 2I/10	(2)	✓	✓	✓	✓	✓	✓
Analogue module 40	(3)	–	–	–	–	1x	2x
Digital module 4I/40	(4)	–	✓	–	–	–	–
Digital module 8I/80	(5)	–	–	✓	–	–	–
COM interface	(6)	✓	✓	✓	–	–	–
Power supply unit 230 V – 24 V	(7)	✓	✓	✓	✓	–	–
Power supply unit 400 V – 24 V	(8)	–	–	–	–	✓	✓
Temperature module 6I for temperature control types	(9)	Optional	Optional	Optional	Optional	Optional	Optional

Table 4: PLC configuration



NOTE:

Depending on the module combination, a different module arrangement may be required for addressing reasons.

- **Frequency converter:**
Frequency converter for load-sensitive speed control of the base-load pump – only on the CC-FC version (item 4).
- **Motor filter:**
Filter for ensuring a sinusoidal motor voltage and for suppressing voltage peaks – only on the CC-FC version (item 5).
- **Fuse protection for drives and frequency converter:**
Fuse protection for the pump motors and the frequency converter. For devices with $P_2 \leq 4.0$ kW: motor protection switches. On the CCe version: circuit breaker for the fuse for the pump mains supply cable (item 6).
- **Contactors/contactor combinations:**
Contactors for switching on the pumps. For devices with $P_2 \geq 5.5$ kW including the thermal trigger for excess current protection (set value: $0.58 \times I_N$) and the time relay for star-delta switching (item 7).

- **Manual-0-automatic switch:**
Switch for selecting the pump modes (item 8)
 - “Manual” (emergency/test mode on mains, motor protection fitted)
 - “0” (pump switched off – cannot be switched on via PLC)
 - “Auto” (pump enabled for automatic mode via PLC)
 On the CCe version, the speed of each pump (0–100%) can be adjusted in manual mode using the manual control.

6.2 Function and operation



DANGER! Risk of fatal injury!

When working on the open switchgear, there is a danger of electric shock from touching the live components.

- **The work must only be carried out by qualified personnel.**
- **Adhere to accident prevention regulations.**



NOTE:

After connecting the switchgear to the supply voltage, as well as after every mains interruption, the switchgear returns to the operating mode set before the power interruption.

6.2.1 Switchgear operating modes

Normal operation of switchgear with frequency converter – CC-FC version (see fig. 3)

On a switchgear with frequency converter, the speed of the base-load pump is controlled in such a way that the current controlled variable corresponds to the setpoint ① (setpoint/actual value comparison). If there is no “external off” signal and no fault, at least the base-load pump runs at minimum speed. If the power requirement rises, the speed of the base-load pump is first increased. If the power requirement cannot be met by this pump, the control system switches on a peak-load pump and, if the requirement increases further, further peak-load pumps. The peak-load pumps run at constant speed, while the speed of the base-load pump is regulated to the setpoint ④ in each case. If the requirement drops until the controlling pump is working in its lower power range and a peak-load pump is no longer required to meet the requirement, the power of the base-load pump briefly rises and the controller switches off the peak-load pump.

Activation and deactivation of the peak-load pump:

The parameter settings required for activation and deactivation of the peak-load pump (switching level ② / ③; delay times) can be made in menu 4.3.3.2. To avoid actual value peaks when activating or actual value troughs when deactivating a peak-load pump, the speed of the base-load pump can be raised or reduced during these switching operations. The frequencies for this “peak filter” can be set in menu 4.3.5.1 – Page 2 (see chapter “Description of menu items” on page 80).

Normal operation of switchgear without frequency converter – CC version (see fig. 4)

The controlled variable is taken from comparison of the setpoint/actual value for switchgear without a frequency converter (mains operation) or with a faulty frequency converter. However, as there is no possibility of load-sensitive speed adjustment on the base-load pump, the system operates as a two-point controller between the switching levels ② and ③.

Activation and deactivation of the peak-load pump:

The peak-load pump is activated and deactivated in the manner described above.

Normal operation of switchgear in the CCe version (see fig. 5)

A selection can be made between two operating modes (4.3.4.4) for switchgear in the CCe version. The setting parameters described for the CC-FC switchgear are used in each case.

Cascade mode corresponds to normal operation of switchgear in the CC-FC version (see fig. 3), with the peak-load pumps actuated at maximum speed.

In Vario mode (see fig. 5), one pump starts as a load-sensitive speed-controlled base-load pump (fig. 5a). If the required power requirement can no longer be met by this pump at maximum speed, another pump starts and takes over the speed control. The previous base-load pump continues at max. speed as a peak-load pump (fig. 5b).

This procedure is repeated as the load increases until the maximum number of pumps is reached (here: 3 pumps – see fig. 5c).

If the requirement falls, the controlling pump is switched off when the minimum speed is reached and a former peak-load pump takes over control.

Pump cycling

To ensure that the load is distributed as evenly as possible between all pumps and balance the running times of the pumps, a choice of pump cycling mechanisms are used. The corresponding settings can be made in menu 4.3.4.2.

If pump cycling depending on operating hours is selected, the system uses the elapsed time indicator and the pump diagnostics (faults, release) to specify the base-load pump (service life optimisation). The time to be set for this cycling mechanism expresses the maximum permitted running time difference.

The cyclical pump cycling changes the base-load pump after the set time has elapsed. The operating hours are not taken into account. With cyclical pump cycling there is the option of switching on a duty change-over pump.

If the impulse cycling mechanism is selected, the base-load pump is changed at every request (after all pumps have been stopped). The operating hours are not taken into account here either.

A pump can be permanently defined as the base-load pump using the pump pre-selection. Independently of the cycling mechanism for the base-load pump, the peak-load pumps are cycled to optimise their running time. This means that the pump with the shortest running time is always switched on first after a pump request, and switched off last when there is a reduction.

Standby pump

A pump can be defined as a standby pump in menu 4.3.4.1. Activating this operating mode leads to a pump not being activated in normal operation. It is switched on only if a pump fails due to a fault. However, the standby pump is subject to standstill monitoring and is included in the test run. Service life optimisation ensures that every pump becomes a standby pump once.

Pump test run

To avoid longer standstill times, a cyclic test run of the pumps is provided. The time between two test runs and the duration of the test run can be specified in menu 4.3.4.3. The test run is deactivated by adjusting the test run interval to 0 hours.

A test run is only performed when the system is at a standstill.

A selection button can be used to choose whether the test run should also be performed if the switchgear has the status “external off”. An interval can also be specified in which no pump test run should take place.

Fault-actuated switchover in multi-pump system

Switchgear with frequency converter – CC-FC version:

If the base-load pump has a fault, it is switched off and another pump is switched onto the frequency converter. If the frequency converter has a fault, the switchgear switches to “auto without frequency converter” operating mode with the associated control characteristics.

Switchgear without frequency converter – CC version:

If the base-load pump has a fault, it is switched off and another pump is used as the base-load pump.

Switchgear in the CCe version:

If there is a pump fault, the frequency converter sends a signal to the switchgear and resets if necessary. Menu 4.2 can be used to specify whether the switchgear automatically resets a fault that is no longer being signalled, or whether a manual confirmation is required.

If the base-load pump has a fault, it is switched off and another pump takes over the control function.

On all switchgear versions, a fault with a peak-load pump always results in it being deactivated and activation of another peak-load pump (including the standby pump if necessary).

**Low water
(in control mode p-c only)**

A low water signal can be sent to the control system via a normally closed contact based on the signal from a suction-side pressure switch, break tank float switch or optional level relay. The pumps are switched off after the adjustable delay time set in menu 3.1 has elapsed. If the signal input is closed again within the delay time, this does not lead to deactivation.

After deactivation due to low water, the system restarts automatically 10 s after the signal input closes. The fault signal is reset automatically after the restart, but can be read out from the history memory.

Monitoring of maximum and minimum values (in control modes p-c and T-c only)

The limit values for safe system operation can be set in menu 4.3.2.2. For monitoring maximum and minimum values, a hysteresis for the corresponding values and a time before triggering of fault processing can be entered in menu 4.3.2.2. This should also create the possibility of hiding measured value peaks or troughs for a short time.

Exceeding the maximum value leads to immediate deactivation of all pumps. After the actual value falls to the switch-on level, normal operation is enabled again after 1 min. The collective fault signal is activated if, within 24 hours, 3 deactivations occur due to the maximum value being exceeded.

Undershooting the minimum value immediately leads to activation of the collective fault signal. There is no deactivation of the pumps (for example pipe burst detection).

External off

It is possible to deactivate the control device externally using a normally closed contact. This function takes precedence; all pumps are deactivated.

Operation in the event of a sensor fault

The behaviour of the switchgear in the event of a sensor fault (for example wire break) can be defined in menu 4.3.2.3. The system is either switched off, runs with all pumps at maximum speed or runs with one pump at a speed that can be adjusted in menu 4.3.5.1 (CC...FC and CCe versions only).

Pump operating mode

In menu 1.1, the operating mode for the relevant pump when activated can be specified with the PLC (manual, off, auto). In order to function correctly, the emergency operation switch (fig. 1 a-e; item 8) must be in the "Auto" position.

For CCe version devices, the speed in "Manual" operating mode can be adjusted in the same menu.

Emergency operation

In the event of the control failing, it is possible to start operation of the pumps individually using the Manual-0-Auto switch (fig. 1a-e; item 8) on the mains (or using manual control with a speed adjustable individually for each pump - CCe version only). This function takes precedence over pump activation by the control.

Setpoint changeover

The control system can work with 3 different setpoints. These are set in menus 3.1 to 3.3.

Setpoint 1 is the reference setpoint. Switching to setpoint 2 or setpoint 3 occurs either after a set time (menus 3.2 and 3.3) or by closing the external digital inputs (according to wiring diagram). The digital inputs have priority over the times, and setpoint 3 has priority over setpoint 2 (see logic diagram under 7.2 "Setpoint changeover").

External setpoint

Remote adjustment of the setpoint is possible using an analogue current signal (optionally a voltage signal) in control modes p-c, Δp-c, ΔT-c and T-c using the corresponding terminals (in accordance with wiring diagram). This operating mode can be selected in menu 3.4. The signal type (0–20 mA or 4–20 mA; 0–10 V, or 2–10 V) is also selected in this menu.

With the signal type 4–20 mA or 2–10 V, a conductivity test is carried out. If the input current falls below 3 mA or 1.5V, the external setpoint is deactivated until a signal greater than or equal to 3 mA or 1.5V is present at the input for the external setpoint again. The control switches to the active setpoint 1, 2 or 3 for the duration of the wire break. No alarm signal is generated.

The input signal is either relative to the sensor measurement range (for example differential pressure sensor 40: 20 mA corresponds to 40 m (water column)). Alternatively, in the temperature control modes the minimum and maximum are set in menu 3.4.

Control mode (see fig. 6)

Control mode is possible using an analogue current signal (optional voltage signal) using the corresponding terminals (according to wiring diagram). This operating mode can be selected in menu 4.3.3.4. The signal type (0–20 mA or 4–20 mA; 0–10 V, or 2–10 V) is also selected in this menu.

The input signal is always relative to the permissible frequency range (menu 4.3.5.1, 0/4 mA or 0/2 V corresponds to f_{\min} ; 20 mA or 10 V corresponds to f_{\max}).

On the CC...FC version, only single-pump operation is possible. On the CCe version, multi-pump operation is also possible. The setting range is split evenly over the number of pumps. Fig. 6 shows an example split for a three-pump system.

**NOTE:**

Control mode deactivates the control type set in menu 4.3.1.

Logic reversal of the collective fault signal

The desired logic for the collective fault signal can be set in menu 4.3.2.4. It is possible to select between negative logic (falling edge in case of a fault) or positive logic (rising edge in case of a fault).

Function of the collective run signal

The desired function of the collective run signal can be set in menu 4.3.2.4. It is possible to select between "Stand-by" (switchgear is ready for operation) and "on" (at least one pump is running).

Frost protection (not in control mode p-c)

A frost protection signal can be sent to the control system via a normally closed contact based on the signal from a frost protection thermostat. If the signal input is opened, a pump is immediately activated at an adjustable speed (see menu 4.3.5.1).

Depending on the selected acknowledgement mode (see menu 4.3.2.5), after the normally closed contact opens the system goes back into the specified automatic mode or manual acknowledgement is required.

Frost protection mode is only possible if the system is switched off by setpoint 2, setpoint 3, an analogue external setpoint or external OFF.

6.2.2 Control modes

The basic control mode for the system can be preselected in menu 4.3.1. In control mode T-C, the effective control direction can be set in menu 4.3.3.3. In the other control modes, the effective direction is fixed and is not visible.



Effective direction	Measuring point	Temperature behaviour	Speed response	Application
	Return (TR)	Rising	Rising	Cooling / supply process with cold water
	Return (TR)	Rising	Falling	Heating / supply process with warm water

Table 5: Effective direction

An electronic signal transmitter (measurement range to be set in menu 4.3.2.3) supplies the control variable actual value as a 4 to 20 mA current signal. For the devices with temperature sensor inputs, the change in resistance of Pt100 or Pt1000 sensors is recorded (optional module required – see “Table 4: PLC configuration” on page 66).

The following control modes can be selected:

Δp -c (constant differential pressure – see fig. 7)

The differential pressure (between two system points) is held constant in accordance with the setpoint H_{set} under changing load conditions (volume flow).

Multi-pump operation is possible.

Δp -v (variable differential pressure – see fig. 8) (CCe/CC...FC only)

If only one pump is running, the control setpoint is adjusted and corrected depending on the volume flow between H_{min} and H_{set} ($H_{set} \geq H_{min} \geq 0.4 \times H_{set}$). The zero-delivery head of the pump must also be entered (menu 3.1).

After load-sensitive cut-in of one or more peak-load pumps, the system operates in Δp -c mode (setpoint H_{set}).

Multi-pump operation is possible. External analogue setpoint specification is not possible.

p-c (constant absolute pressure – see fig. 9)

The output pressure of the system is held constant in accordance with the setpoint p_{set} under changing load conditions (volume flow).

Multi-pump operation is possible.

ΔT -c (constant differential temperature – see fig. 10)

The differential temperature (between two system points; feed/return) is held constant in accordance with the setpoint ΔT under changing load conditions (volume flow).

Multi-pump operation is possible.

 ΔT -v (variable differential temperature – see fig. 10 and fig. 11)

The differential temperature (between two system points; feed/return) is held constant in accordance with the setpoint ΔT under changing load conditions (volume flow), see fig. 10.

The setpoint ΔT is variably set depending on the external or process temperature (see fig. 11). You can choose between rising and falling dependency on the control input.

Multi-pump operation is possible.

T-c (constant temperature – see fig. 12)

The temperature at a system point is held constant in accordance with T_{set} under changing load conditions. The effective direction can be selected as shown in Table 5.

Multi-pump operation is possible.

 $n = f(T_x)$ (speed controller – depending on temperature – see fig. 13)

The speed of the pump(s) is adjusted depending on the input temperature (the temperature input used can be selected in menu 4.3.1). You can choose between rising and falling dependency on the control input.

With single pump operation, the speed is adjusted between f_{min} and f_{max} .

On the CCe version, multi-pump operation is also possible. The setting range is split evenly over the number of pumps. fig. 13 shows an example split for a three-pump system

6.2.3 Motor protection**Excess temperature protection**

Motors with a thermal winding contact signal an excess winding temperature to the control device by opening a bimetal strip contact. The thermal winding contact is connected according to the wiring diagram.

Faults on motors that are equipped with a temperature-dependent resistor (PTC) for excess temperature protection can be detected using optional evaluation relays.

Overcurrent protection

Direct starting motors are protected by motor protection switches with thermal and electromagnetic tripping devices. The trigger current (I_{nom}) must be set directly on the motor protection switch.

Motors with Y- Δ starting are protected by thermal overload relays. These are installed directly on the motor contactors. The trigger current must be set and is $0.58 \times I_{nom}$ with the Y- Δ starting of the pumps used.

All motor protection devices protect the motor during operation with the frequency converter or in mains operation. Pump faults which reach the switchgear result in deactivation of the corresponding pump and activation of the collective fault signal. After the cause of the fault has been rectified, it is necessary to acknowledge the fault.

The motor protection is also active in emergency operation, and leads to deactivation of the corresponding pump.

On the CCe version, the pump motors protect themselves using mechanisms integrated in the frequency converters. The error messages from the frequency converters are handled in the switchgear as described above.

6.2.4 Operation of the switchgear

Controls

- **Main switch** On/Off (lockable in Off position)
- The **touch display** (graphics-capable) shows the operating statuses of the pumps, the controller and the frequency converter. Additionally, all switchgear parameters can be set using the display. The backlight changes depending on the operating status:
 - GREEN – Switchgear OK
 - RED – Fault
 - ORANGE – Fault still present but has been acknowledged

The relevant controls in a specific context appear on the touch display and can be selected directly. Input fields for parameters have a heavily marked frame. Soft keys have a 3D look.

In addition to plain text displays, the following graphic parameter symbols are used, see following tables:

“Table 6: Parameter symbols” on page 73,

“Table 7: Operating mode symbols” on page 74,

“Table 8: Control symbols” on page 76,

“Table 9: Pump symbols” on page 77.

Parameter symbols:









Symbol	Function/description	Availability
	Switch-off time, e.g. for setpoint changeover	All device versions
	Input signal	All device versions
	Start-up time, e.g. for setpoint changeover	All device versions
	Set time/duration, for example for pump test run	All device versions
	Follow-up time for protection against low water level	All device versions
	Delay time	All device versions
	Setpoint	All device versions
	Actual value	All device versions

Table 6: Parameter symbols

Operating modes:





































Symbol	Function/description	Availability
	Switchgear is operating with a fault (FC fault, pumps running in cascade connection)	CC...FC
	Switchgear is operating with a fault (sensor fault, missing actual value)	All device versions
	Switchgear deactivated by external off	All device versions
	Switchgear is in external control mode	All device versions
	CCE - Cascade pump operating mode	CCE
	CCE - Vario pump operating mode	CCE

Table 7: Operating mode symbols

Controls:

Symbol	Function/description	Availability
	Call up main menu	All device versions
	Return to main menu screen	All device versions
	Scrolling within a menu level	All device versions
	Move up one menu level	All device versions
	Operator action – Log out Displayed status – User is logged in	All device versions
	Operator action – Call up login window Displayed status – User is logged out	All device versions
	Switched off	All device versions
	Switched on	All device versions
	Automatic mode	All device versions
	Call up operation level, for example for a pump	All device versions
	Manual mode, for example for a pump	All device versions

Symbol	Function/description	Availability
	Call up information	All device versions
	Call up parameter settings	All device versions
	Operation	All device versions
	Stand-by	All device versions
	Falling signal during activation of collective fault signal	All device versions
	Rising signal during activation of collective fault signal	All device versions
	Signal type 0 to 20 mA or 0 to 10 V	All device versions
	Signal type 4 to 20 mA or 2 to 10 V	All device versions
	<ul style="list-style-type: none"> • Scroll (previous value) for example in fault signal history • Negative effective direction for PID controller 	All device versions
	Quick scroll or change value	All device versions
	<ul style="list-style-type: none"> • Scroll (next value) in fault signal history • Positive effective direction for PID controller 	All device versions
	Quick scroll or change value	All device versions
	Single pump operation (control mode)	CCe
	Multi-pump operation (control mode)	CCe
	Select language (German)	All device versions
	Select language (French)	All device versions
	Select language (English)	All device versions
	Select language (Spanish)	All device versions
	Select language (Russian)	All device versions









Symbol	Function/description	Availability
	Select language (Turkish)	All device versions
	Select language (Polish)	All device versions
	Select sensor for ambient temperature	All device versions
	Select sensor for process temperature	All device versions
	Positive dependency between measured value and correcting variable	All device versions
	Negative dependency between measured value and correcting variable	All device versions
	Select previous value	All device versions
	Select next value	All device versions
	Activate overlapping pump cycling	All device versions

Table 8: Control symbols

Pump symbols:













Symbol	Function/description	Availability
	The pump is selected for FC operation and is not running	CC...FC
	The pump is selected for FC operation and is running	CC CC...FC
	The pump is selected for manual operation and is not running	CC...FC
	The pump is selected for manual operation and is running	All device versions
	The pump is selected for mains operation and is running	CC CC...FC
	The pump is operating controlled and is running at minimum speed	CCe
	The pump is running uncontrolled at maximum speed	CCe
	The pump is ready for operation and is not running	CCe
	Alternately with the symbol above indicates a fault with a pump	CCe
	The pump is a standby pump	All device versions
	A pump test run is currently running on this pump	All device versions
	Standby pump function is activated	All device versions
	Standby pump is in use	All device versions

Table 9: Pump symbols

6.2.5 Menu structure

The menu structure for the control system has the following structure, see Fig. 14: "Menu structure – Part 1" on page 78 and Fig. 15: "Menu structure – Part 2" on page 79 below.

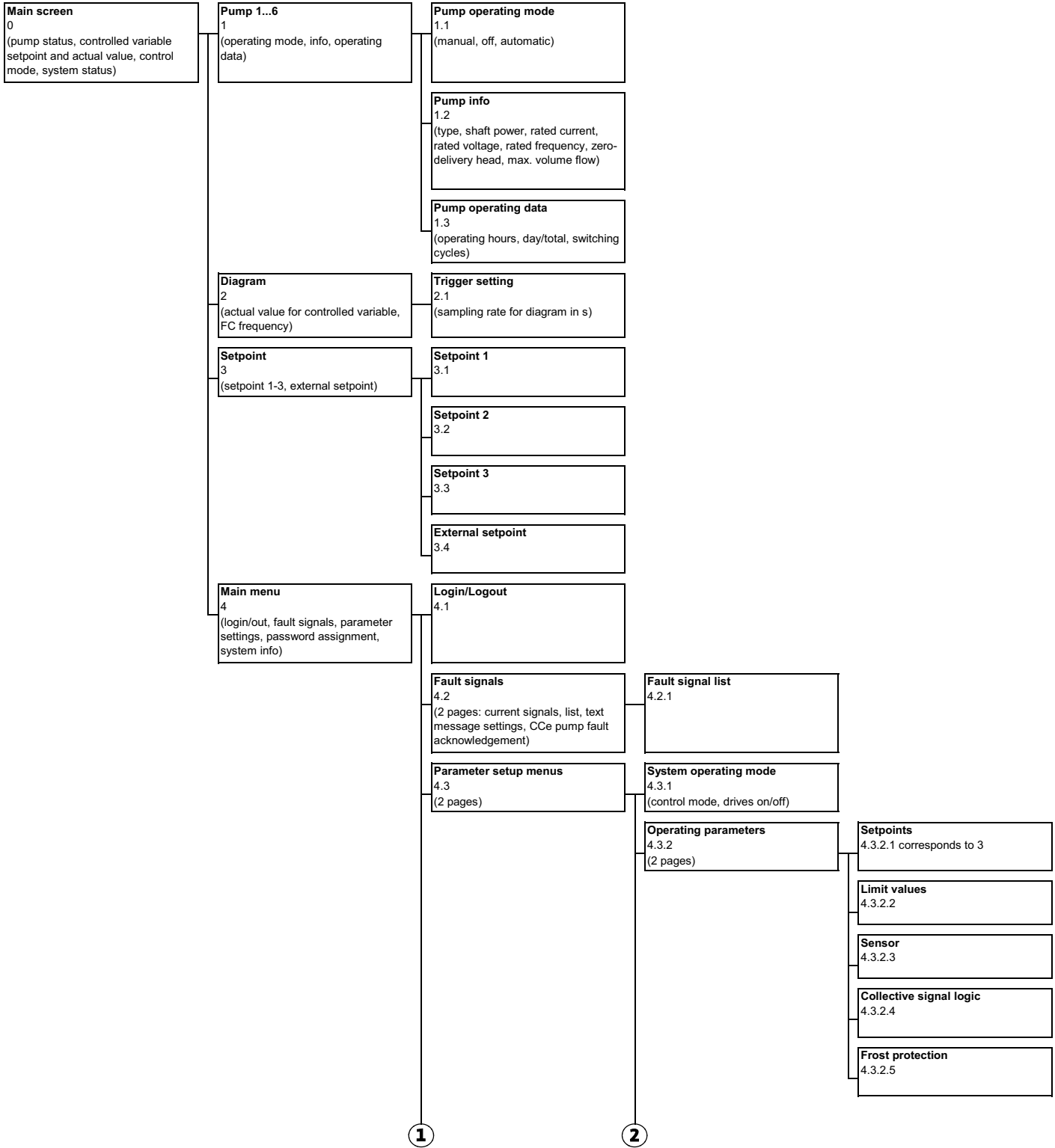

Fig. 14: Menu structure – Part 1

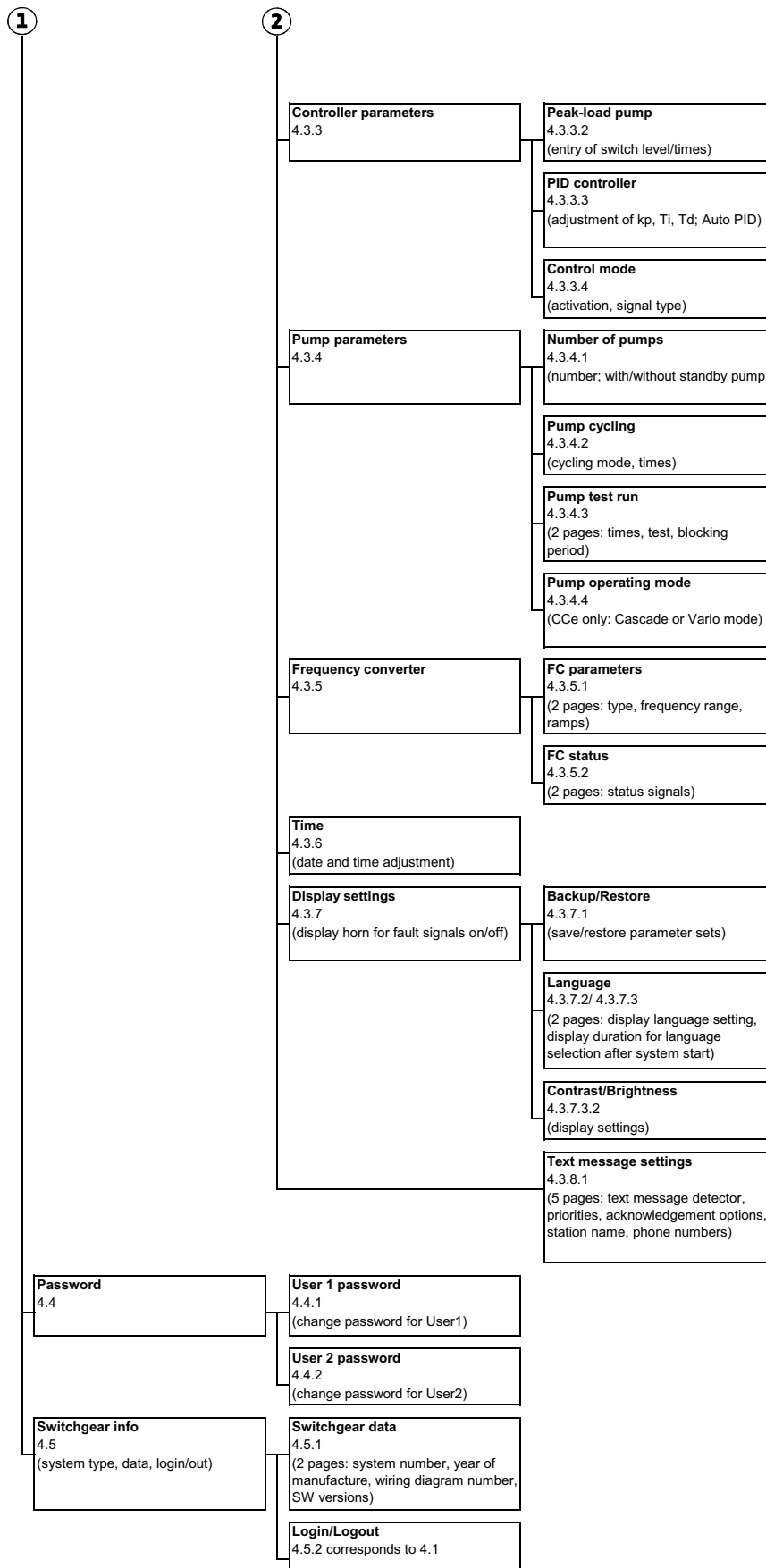

Fig. 15: Menu structure - Part 2

6.2.6 User levels

Operation and parameterisation of the switchgear is protected by a three-stage security system. After entry of the corresponding password (menu 4.1 or 4.5.2), the system is released at the related user level (shown by the indicators next to the level designations). The user accesses the system by pressing the password input field and entering the correct password.

User 1:

At this level (typically: local users, for example building caretaker) the display of almost all menu item is enabled. Parameter entry is limited. The password (4 digit; numerical) for this user level can be assigned in menu 4.4.1 (factory setting: 1111).

User 2:

At this level (typically: operator) display of all menu items is enabled with the exception of simulation mode. Parameter entry is possible with almost no limitations.

The password (4 digit; numerical) for this user level can be assigned in menu 4.4.2 (factory setting: 2222).



NOTE:

The **Service** user level is reserved for WILO customer service.









Selecting the display language

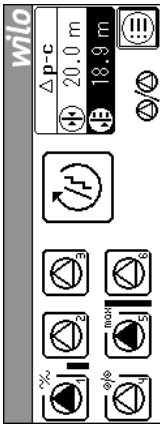



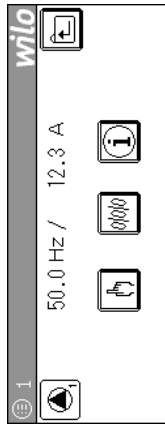

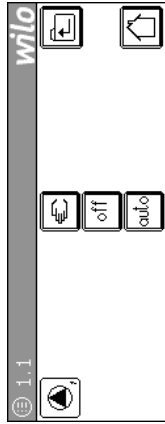

The desired display language can be selected after switching on the control device. This selection screen remains visible for a time that can be set in menu 4.3.7.3.

Language selection is also possible at any time using menu 4.3.7.2.

Description of menu items

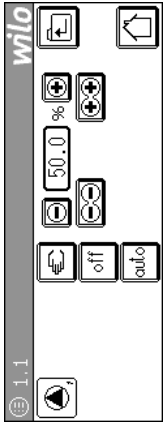



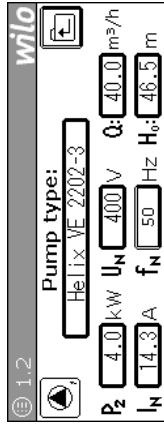

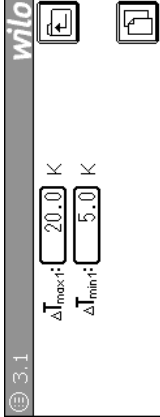
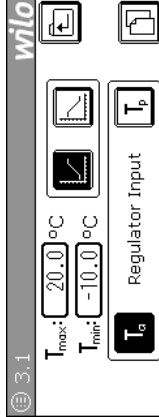

Refer to the following “Menu no. ...” tables for a description of the individual menu items

Menu-no./	Display	Description	Setting parameters/functions	Factory setting
Called by:	Visible for: (1) User 1 and higher (2) User 2 and higher (S) Service		Adjustable by: (1) User 1 and higher (2) User 2 and higher (S) Service	
0	(1) Main screen 	Display of operating states of pumps, the active setpoint and the current actual value. Call-up of Pump settings:  Diagram display:  Setpoint menu:  Main menu:  Note: The displayed controlled variable and its parameters depend on the control mode. The bars beside the pump symbols show the current speed of the pump (CCe, CC-FC). The large symbol in the middle shows the current state of the system or the pump operating mode for CCe (cascade or Vario operating mode).	-	-
1	(1) Pump 1 to 6 	Call-up of Operating mode:  Pump parameters:  Operating data:  for pumps 1 to 6. The number of pumps depends on the system. For the pump running on the frequency converter (FC), the ACTUAL current and ACTUAL frequency of the pump are displayed as well (CC-FC only).	-	-

Menu no./	Display	Description	Setting parameters/functions	Factory setting
<p>Called by: (1) User 1 and higher (2) User 2 and higher (5) Service</p> <p>Adjustable by: (1) User 1 and higher (2) User 2 and higher (5) Service</p>				
1.1		<p>• Setting of pump operating mode:</p> <p>Manual mode (mains operation): </p> <p>Off (no start via control): </p> <p>Automatic (FC frequency converter/mains operation via control): </p>	<p>(2) Operating mode: Manual/Off/Automatic</p>	Automatic
1.1		<p>• Setting of pump operating mode:</p> <p>Manual mode (constant operation): </p> <p>Off (no start via control): </p> <p>Automatic (operation via control): </p> <p>Setting of speed in manual mode</p>	<p>(2) Operating mode: Manual/Off/Automatic</p> <p>(2) Speed [%]: 0.0 to 100.0</p> <p>(2) Manual mode</p>	Automatic 50.0 %
1.2		<p>• Display of pump information: Type, shaft power P₂, rated current, rated voltage, rated frequency (50/60Hz), maximum flow rate and zero-delivery head.</p> <p>Attention: During commissioning, enter pump information for pump 1 only. Data is transferred automatically from pump 1 to pumps 2 to 6.</p>	<p>(2) Pump type</p> <p>(2) Shaft power P₂ [kW]: 0.2 to 500.0</p> <p>(2) Rated current I_N [A]: 0.2 to 999.9</p> <p>(2) Rated frequency f_N [Hz]: 50/60</p> <p>(2) Q max [m³/h]: 0 to 500.0</p> <p>(2) Zero-delivery head [m]: 0 to 999.0</p>	System-specific 1.5 kW 3.7 A 50 Hz 0 m ³ /h 0 m

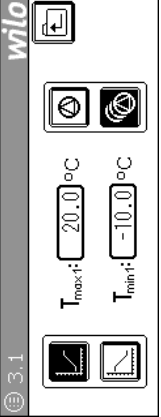
Menu no./	Display	Description	Setting parameters/functions	Factory setting
<p>Called by: (1) User 1 and higher (2) User 2 and higher (S) Service</p> <p>Visible for: (1) User 1 and higher (2) User 2 and higher (S) Service</p>				
1.3		<ul style="list-style-type: none"> • Display of total operating hours (since commissioning) • Display of daily operating hours • Display of total switching cycles (number of times switched ON since commissioning) 	–	–
2		<ul style="list-style-type: none"> • Measured value diagram for time-resolved presentation of actual value (dependent on control mode) and FC frequency in Hz (CC...FC) or % (CCe) • Call-up of trigger settings and simulation mode 	–	–
2.1		<ul style="list-style-type: none"> • Setting of time basis (trigger time) of measured value diagram 	(1) Trigger time [s]: 0 to 180	5 s
3		<ul style="list-style-type: none"> • Call-up of settings for setpoints 1-3 • Call-up of external setpoint 	–	–

Menu no./	Display	Description	Setting parameters/functions	Factory setting
<p>Called by: (1) User 1 and higher (2) User 2 and higher (S) Service</p>				
<p>Adjustable by: (1) User 1 and higher (2) User 2 and higher (S) Service</p>				
3.1 (p-c)	<p>(1) Setpoint 1</p> <p>Set value 1</p>	<ul style="list-style-type: none"> Setting of 1st setpoint (reference setpoint) and the follow-up time for dry-running protection Follow-up time for dry-running protection: 	<p>(2) Setpoint 1 [m]: 0.0 to sensor max</p> <p>(2) t_{TLs} [s]: 0 to 180</p>	<p>4.0 m</p> <p>180 s</p>
3.1 ($\Delta p-c$)	<p>(1) Setpoint 1</p> <p>Set value 1</p>	<ul style="list-style-type: none"> Setting of 1st setpoint (reference setpoint) 	<p>(2) Setpoint 1 [m]: 0.0 to sensor max</p>	<p>20.0 m</p>
3.1 ($\Delta p-v$)	<p>(1) Setpoint 1</p> <p>Set value 1</p>	<ul style="list-style-type: none"> Setting of 1st setpoint (reference setpoint) Adjustment of the zero-delivery head (H_0) Adjustment of the minimum zero-delivery head (H_{min1}) 	<p>(2) H_0 [m]: 0.0 to sensor max</p> <p>(2) Setpoint 1 [m]: 0.0 to sensor max</p> <p>(2) H_{min1} [m]: 0.4*setpoint1 to sensor max</p>	<p>30.0 m</p> <p>20 m</p> <p>10 m</p>
3.1 ($\Delta T-c$)	<p>(1) Setpoint 1</p> <p>Set value 1</p>	<ul style="list-style-type: none"> Setting of 1st differential temperature between feed and return 	<p>(2) ΔT_1 [K]: 1.0 to 700.0</p>	<p>1.0 K</p>

Menu no./	Display	Description	Setting parameters/functions	Factory setting
<p>Adjustable by:</p> <p>(1) User 1 and higher (2) User 2 and higher (S) Service</p>				
3.1	<p>Visible for:</p> <p>(1) User 1 and higher (2) User 2 and higher (S) Service</p> <p>(1) Setpoint 1</p>  <p>Set value 1</p>	<ul style="list-style-type: none"> Setting of permissible temperature range for the 1st differential temperature between feed and return temperature for heating or cooling mode 	<p>(2) ΔT_{max1} [K]: ΔT_{min1} to 700.0</p> <p>(2) ΔT_{min1} [K]: 1.0 to 100.0</p> <p>20.0 K 1.0 K</p>	
3.1	<p>(1) Setpoint 1 parameters</p>  <p>Regulator Input</p> <p>Set value 1</p>	<ul style="list-style-type: none"> Temperature range settings for the outdoor or process temperature as a control input <p>Outdoor temperature: </p> <p>Process temperature: </p> <p>Control input rising: </p> <p>Control input falling: </p>	<p>(2) T_{max} [°C]: ($T_{min}+1.0$) to 500.0</p> <p>(2) T_{min} [°C]: -200.0 to 499.0</p> <p>(2) Control input: Outdoor temperature/ Process temperature</p> <p>(2) Direction of control input: Rising/Falling</p> <p>20.0 °C -10.0 °C - Rising</p>	
3.1	<p>(1) Setpoint 1</p>  <p>Set value 1</p>	<ul style="list-style-type: none"> Setting the temperature range for speed control of a pump in relation to the input temperature. <p>Tv1: Feed temperature Tr1: Return temperature Ta: Outdoor temperature Tp: Process temperature</p> <p>Control input rising: </p> <p>Control input falling: </p> <p>The control mode can be used on one () or all () pumps (CCe only).</p>	<p>(2) T_{max1} [°C]: $T_{min1}...500.0$</p> <p>(2) T_{min1} [°C]: -200.0 to 499.0</p> <p>(2) Pump control: One/All</p> <p>(2) Dependency: Rising/Falling</p> <p>20.0 °C - 10 °C All Rising</p>	

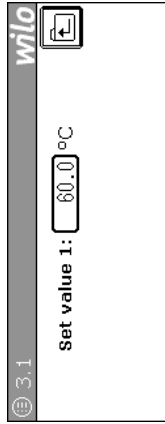
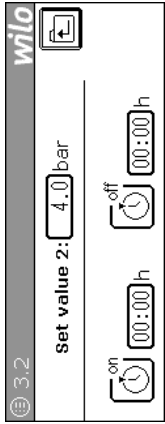
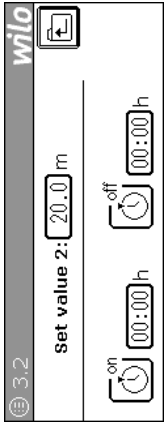
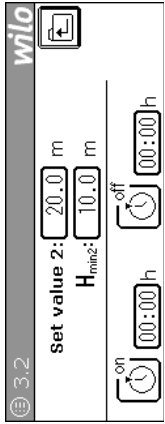

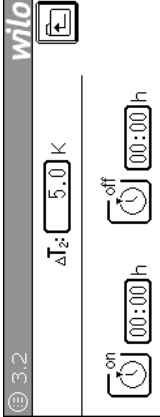
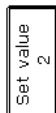
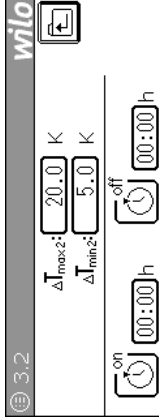
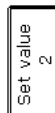
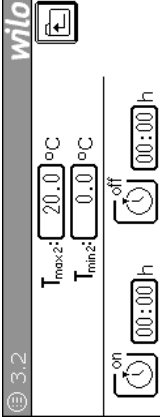
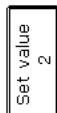
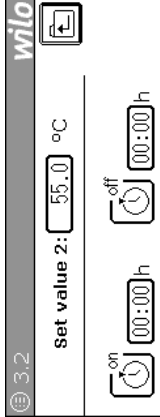
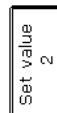

Menu no./	Display	Description	Setting parameters/functions	Factory setting
<p>Called by: (1) User 1 and higher (2) User 2 and higher (S) Service</p> <p>Adjustable by: (1) User 1 and higher (2) User 2 and higher (S) Service</p>				
3.1	<p>(1) Setpoint 1</p>  <p>Set value 1</p>	<ul style="list-style-type: none"> Setting the target temperature for speed control of the pump in relation to the input temperature. <p>Tvl: Feed temperature Trl: Return temperature Ta: Outdoor temperature Tp: Process temperature Tai: 4–20mA signal, analogue input 1</p>	<p>(2) T_1 [°C]: -272.0 to 999.9</p>	60.0 °C
3.2	<p>(1) Setpoint 2</p>  <p>Set value 2</p>	<ul style="list-style-type: none"> Setting of 2nd setpoint, and the switching times to setpoint 2 	<p>(2) Setpoint 2 [bar]: 0.0 to sensor max (2) On [Hour:Min]: 00:00 to 23:59 (2) Off [Hour:Min]: 00:00 to 23:59</p>	4.0 bar 00:00 00:00
3.2	<p>(1) Setpoint 2</p>  <p>Set value 2</p>	<ul style="list-style-type: none"> Setting of 2nd setpoint, and the switching times to setpoint 2 	<p>(2) Setpoint 2 [m]: 0.0 to sensor max (2) On [Hour:Min]: 00:00 to 23:59 (2) Off [Hour:Min]: 00:00 to 23:59</p>	20.0 m 00:00 00:00
3.2	<p>(1) Setpoint 2</p>  <p>Set value 2</p>	<ul style="list-style-type: none"> Setting of 2nd setpoint Adjustment of the minimum zero-delivery head (H_{min2}) Setting of the switching times to setpoint 2 	<p>(2) Setpoint 2 [m]: 0.0 to sensor max (2) H_{min2} [m] 0.0 to sensor max (2) On [Hour:Min]: 00:00 to 23:59 (2) Off [Hour:Min]: 00:00 to 23:59</p>	20.0 m 10.0 m 00:00 00:00

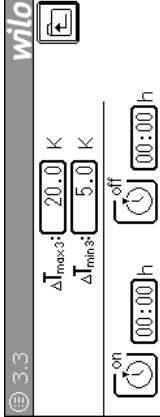
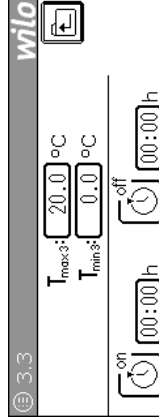
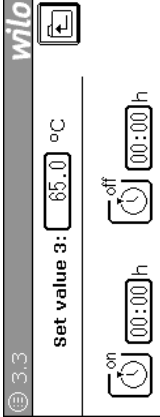
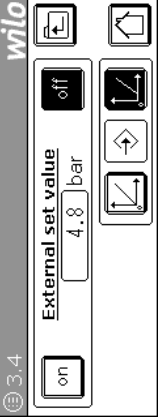

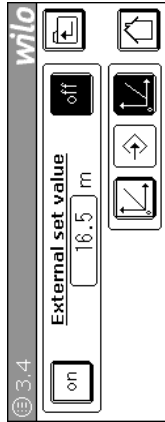
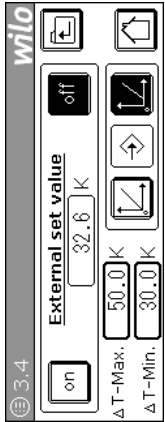
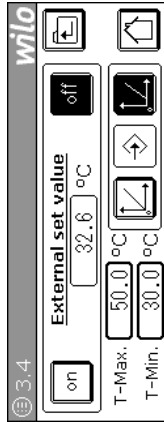

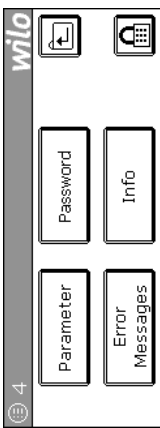
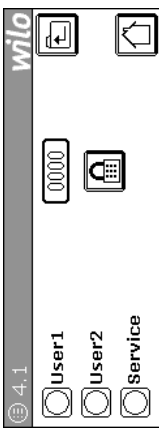
Menu no./	Display	Description	Setting parameters/functions	Factory setting
Called by: (1) User 1 and higher (2) User 2 and higher (S) Service				
Adjustable by: (1) User 1 and higher (2) User 2 and higher (S) Service				
3.2	(1) Setpoint 2  (ΔT-c) 	<ul style="list-style-type: none"> Setting of 2nd differential temperature between feed and return Setting of the switching times to 2nd differential temperature 	(2) ΔT ₂ [K]: 5.0 to 700.0 (2) On [Hour:Min]: 00:00 to 23:59 (2) Off [Hour:Min]: 00:00 to 23:59	5.0 K 00:00 00:00
3.2	(1) Setpoint 2  (ΔT-v) 	<ul style="list-style-type: none"> Setting of permissible temperature range for the 2nd differential temperature between feed and return temperature Setting of the switching times to setpoint 2 	(2) ΔT _{max2} [K]: ΔT _{min2} to 700.0 (2) ΔT _{max2} [K]: 5.0 to 100.0 (2) On [Hour:Min]: 00:00 to 23:59 (2) Off [Hour:Min]: 00:00 to 23:59	20.0 K 5.0 K 00:00 00:00
3.2	(1) Setpoint 2  (n=(Tx)) 	<ul style="list-style-type: none"> Setting of 2nd temperature range for speed control of a pump in relation to the input temperature Setting of the switching times to 2nd temperature range 	(2) T _{max2} [°C]: (ΔT _{min2} +1) to 500.0 (2) T _{min2} [°C]: -200.0 to 499.0 (2) On [Hour:Min]: 00:00 to 23:59 (2) Off [Hour:Min]: 00:00 to 23:59	20.0 °C -10.0 °C 00:00 00:00
3.2	(1) Setpoint 2  (T-c) 	<ul style="list-style-type: none"> Setting of 2nd target temperature for speed control of a pump in relation to the input temperature Setting of the switching times to 2nd temperature range 	(2) T ₂ [°C]: -272.0 to 999.9 (2) On [Hour:Min]: 00:00 to 23:59 (2) Off [Hour:Min]: 00:00 to 23:59	55.0 °C 00:00 00:00

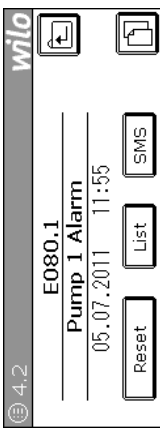

Menu no./	Display	Description	Setting parameters/functions	Factory setting
Called by: (1) User 1 and higher (2) User 2 and higher (5) Service				
Adjustable by: (1) User 1 and higher (2) User 2 and higher (5) Service				
3.3 (p-c)	<p>(1) Setpoint 3</p> <p>Set value 3: 4.0 bar</p> <p>on 00:00 h</p> <p>off 00:00 h</p>	• Setting of 3rd setpoint • Setting of the switching times to setpoint 3	(2) Setpoint 3 [bar]: 0.0 to sensor max (2) On [Hour:Min]: 00:00 to 23:59 (2) Off [Hour:Min]: 00:00 to 23:59	4.0 bar 00:00 00:00
3.3 (Δp-c)	<p>(1) Setpoint 3</p> <p>Set value 3: 20.0 m</p> <p>on 00:00 h</p> <p>off 00:00 h</p>	• Setting of 3rd setpoint • Setting of the switching times to setpoint 3	(2) Setpoint 3 [m]: 0.0 to sensor max (2) On [Hour:Min]: 00:00 to 23:59 (2) Off [Hour:Min]: 00:00 to 23:59	20.0 m 00:00 00:00
3.3 (Δp-v)	<p>(1) Setpoint 3</p> <p>Set value 3: 20.0 m</p> <p>H_{min3}: 10.0 m</p> <p>on 00:00 h</p> <p>off 00:00 h</p>	• Setting of 3rd setpoint • Adjustment of the minimum zero-delivery head (H _{min3}) • Setting of the switching times to setpoint 3	(2) Setpoint 3 [m]: 0.0 to sensor max (2) H _{min3} [m] 0.0 to sensor max (2) On [Hour:Min]: 00:00 to 23:59 (2) Off [Hour:Min]: 00:00 to 23:59	20.0 m 10.0 m 00:00 00:00
3.3 (ΔT-c)	<p>(1) Setpoint 3</p> <p>ΔT: 5.0 K</p> <p>on 00:00 h</p> <p>off 00:00 h</p>	• Setting of 3rd differential temperature between feed and return • Setting of the switching times to 3rd differential temperature	(2) ΔT ₃ [K]: 5.0 to 700.0 (2) On [Hour:Min]: 00:00 to 23:59 (2) Off [Hour:Min]: 00:00 to 23:59	5.0 K 00:00 00:00

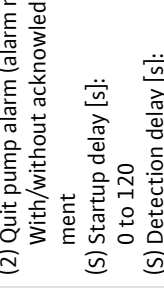
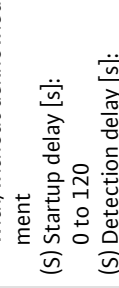
Menu no./	Display	Description	Setting parameters/functions	Factory setting
<p>Adjustable by:</p> <p>(1) User 1 and higher (2) User 2 and higher (S) Service</p>				
3.3	<p>Visible for:</p> <p>(1) User 1 and higher (2) User 2 and higher (S) Service</p> <p>(1) Setpoint 3</p>  <p>Set value 3</p>	<ul style="list-style-type: none"> Setting of permissible temperature range for the 3rd differential temperature between feed and return temperature Setting of the switching times to setpoint 3 	<p>(2) $\Delta T_{\max 3}$ [K]: ($\Delta T_{\min 3+1}$) to 700.0</p> <p>(2) $T_{\min 3}$ [K]: 5.0 to 100.0</p> <p>(2) On [Hour:Min]: 00:00 to 23:59</p> <p>(2) Off [Hour:Min]: 00:00 to 23:59</p>	<p>20.0 K</p> <p>5.0 K</p> <p>00:00</p> <p>00:00</p>
3.3	<p>(1) Setpoint 3</p>  <p>Set value 3</p>	<ul style="list-style-type: none"> Setting of 3rd temperature range for speed control of a pump in relation to the input temperature Setting of the switching times to 3rd temperature range 	<p>(2) $T_{\max 3}$ [°C]: $\Delta T_{\min 3}$ to 500.0</p> <p>(2) $T_{\min 3}$ [°C]: -200.0 to 499.0</p> <p>(2) On [Hour:Min]: 00:00 to 23:59</p> <p>(2) Off [Hour:Min]: 00:00 to 23:59</p>	<p>20.0 °C</p> <p>-10.0 °C</p> <p>00:00</p> <p>00:00</p>
3.3	<p>(1) Setpoint 3</p>  <p>Set value 3</p>	<ul style="list-style-type: none"> Setting of 3rd target temperature for speed control of a pump in relation to the input temperature Setting of the switching times to 3rd temperature range 	<p>(2) T_2 [°C]: -272.0 to 999.9</p> <p>(2) On [Hour:Min]: 00:00 to 23:59</p> <p>(2) Off [Hour:Min]: 00:00 to 23:59</p>	<p>65.0 °C</p> <p>00:00</p> <p>00:00</p>
3.4	<p>(1) External setpoint</p>  <p>External set value</p>	<ul style="list-style-type: none"> Activation of the external setpoint and selection of signal type (0 to 20mA or 4 to 20 mA): Display of external setpoint <p>Note: The external setpoint refers to the measuring range of the selected sensor.</p>	<p>(2) External setpoint: off/on</p> <p>(2) Signal type [mA]: 0 to 20/4 to 20</p>	<p>off</p> <p>4 to 20 mA</p>



Menu no./	Display	Description	Setting parameters/functions	Factory setting
<p>Called by: (1) User 1 and higher (2) User 2 and higher (S) Service</p> <p>Adjustable by: (1) User 1 and higher (2) User 2 and higher (S) Service</p>				
3.4	 <p>(Δp-c)</p> <p>External set value</p>	<ul style="list-style-type: none"> Activation of external setpoint and selection of signal type (0 to 20 mA or 4 to 20 mA) Display of external setpoint <p>Note: The external setpoint refers to the measuring range of the selected sensor.</p>	(2) External setpoint: off/on (2) Signal type [mA]: 0 to 20/4 to 20	off 4 to 20 mA
3.4	 <p>(ΔT-c)</p> <p>External set value</p>	<ul style="list-style-type: none"> Activation of external setpoint and selection of signal type (0 to 20 mA or 4 to 20 mA) Display of external setpoint <p>Note: The external setpoint is between T-Min and T-Max.</p>	(2) External setpoint: off/on (2) Signal type [mA]: 0 to 20/4 to 20 (2) T-Max [K]: (T _{min} + 1.0) to 700.0 (2) T-Min [K]: -200.0 to 700.0	off 4 to 20 mA 50.0 K 30.0 K
3.4	 <p>(T-c)</p> <p>External set value</p>	<ul style="list-style-type: none"> Activation of external setpoint and selection of signal type (0 to 20 mA or 4 to 20 mA) Display of external setpoint <p>Note: The external setpoint is between T-Min and T-Max.</p>	(2) External setpoint: off/on (2) Signal type [mA]: 0 to 20/4 to 20 (2) T-Max [°C]: (T _{min} + 1.0) to 999.0 (2) T-Min [°C]: -272.0 to 998.0	off 4 to 20 mA 50.0 °C 30.0 °C

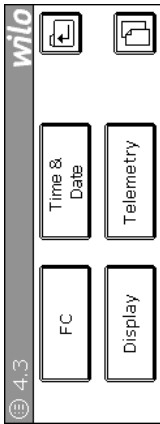
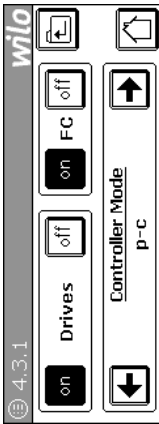

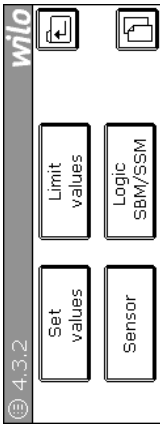
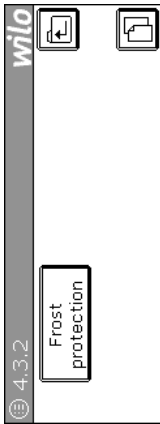

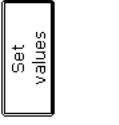
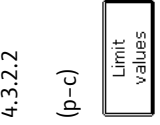
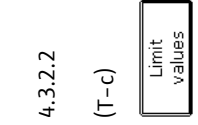
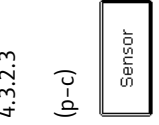

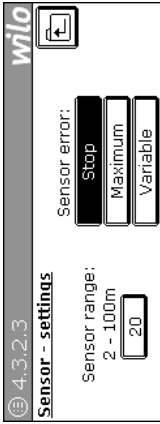
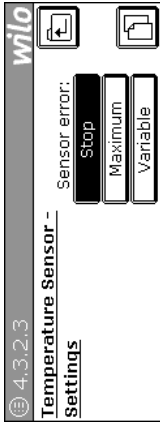
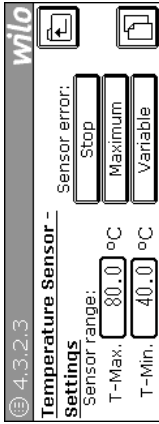

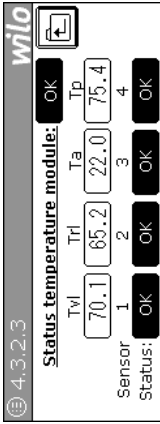
Menu no./	Display	Description	Setting parameters/functions	Factory setting
Called by: (1) User 1 and higher (2) User 2 and higher (5) Service	Visible for: (1) User 1 and higher (2) User 2 and higher (5) Service		Adjustable by: (1) User 1 and higher (2) User 2 and higher (5) Service	
4	 <p>(1) Main menu</p>	<ul style="list-style-type: none"> Calling up fault signals, parameter settings, setting the password System information Login/logout 	–	–
4.1	 <p>(1) Login/logout</p>	<ul style="list-style-type: none"> Entry of password for login (User1, User2, Service) Display of login status Logout possible by pressing the login symbol <p>Logout: </p>	Password entry	–
4.2	 <p>(1) Fault signals (page 1 of 2)</p>	<ul style="list-style-type: none"> Display of current fault signals with time stamp (these are switched through cyclically when there are several signals) Local reset of faults Call-up of fault signal list Call-up of text message settings <p>Call-up of acknowledgement options for CCe: </p>	<ul style="list-style-type: none"> (1) Reset (1) List (1) Text message 	– – –

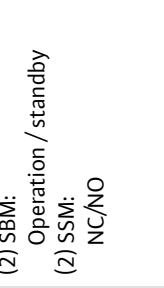
Menu no./	Display	Description	Setting parameters/functions	Factory setting
<p>Called by:</p> <p>(1) User 1 and higher</p> <p>(2) User 2 and higher</p> <p>(S) Service</p>	<p>Visible for:</p> <p>(1) User 1 and higher</p> <p>(2) User 2 and higher</p> <p>(S) Service</p>	<p>Adjustable by:</p> <p>(1) User 1 and higher</p> <p>(2) User 2 and higher</p> <p>(S) Service</p>		
4.2	<p>(1) Fault signals (page 2 of 2)</p> 	<ul style="list-style-type: none"> With Cce, pump faults can be acknowledged automatically or manually. The startup delay determines the maximum time that the controller waits for the electronic pumps to be ready after the system is switched on. If the pumps are ready before this, the system will start before this time elapses, if there is demand. If a pump is not ready after this time, a pump fault is reported. The detection delay causes short-term signals from the electronic pumps to have no effect. 	<p>(2) Quit pump alarm (alarm reset):</p> <p>With/without acknowledgment</p> <p>(S) Startup delay [s]:</p> <p>0 to 120</p> <p>(S) Detection delay [s]:</p> <p>0.1 to 10</p>	<p>Without acknowledgment</p> <p>20 s</p> <p>2.5 s</p>
4.2.1	<p>(1) Fault signal list</p> 	<ul style="list-style-type: none"> Display of fault signal history (35 storage locations) with date/time stamp Scrolling of fault signal history with: <ul style="list-style-type: none"> Upwards:  Downwards:  	<ul style="list-style-type: none"> Review of fault signals 	-
4.3	<p>(1) Parameter setup menu (page 1 of 2)</p> 	<ul style="list-style-type: none"> Call-up of the system menu Call-up of the operating parameters menu Call-up of the controller parameters menu Call-up of the pump parameters menu 	-	-



Menu no./	Display	Description	Setting parameters/functions	Factory setting
<p>Called by: (1) User 1 and higher (2) User 2 and higher (S) Service</p> <p>Visible for: (1) User 1 and higher (2) User 2 and higher (S) Service</p> <p>Adjustable by: (1) User 1 and higher (2) User 2 and higher (S) Service</p>				
4.3		<ul style="list-style-type: none"> Call-up of the FC (frequency converter) menu Call-up of the time and date menu Call-up of the display settings menu Call-up of the text message settings menu (telemetry) 	-	-
4.3.1		<ul style="list-style-type: none"> Switching the drives and the FC (frequency converter) on and off (CC...FC only). Defining the control mode of the system. <p>Select using the buttons  and </p>	(2) Drives: On/Off (2) FC (frequency converter): On/Off (2) Control mode: System-specific	Off On -
4.3.2		<ul style="list-style-type: none"> Call-up of the setpoints menu Call-up of the limit values menu (only for control modes p-c and T-c) Call-up of the sensor settings menu Call-up of the logic menu for collective run signal and collective fault signal 	-	-
4.3.2		<ul style="list-style-type: none"> Call-up of frost protection parameters menu 	-	-



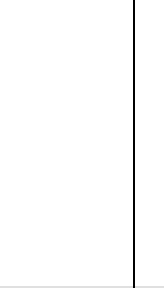

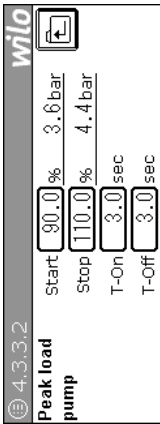
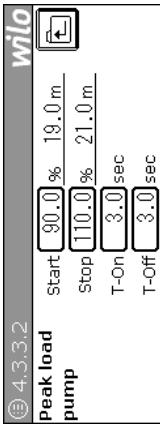
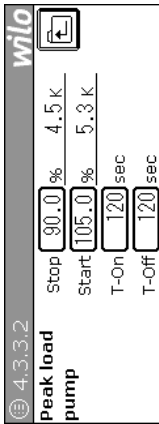
Menu no./	Display	Description	Setting parameters/functions	Factory setting
<p>Called by: (1) User 1 and higher (2) User 2 and higher (S) Service</p> <p>Adjustable by: (1) User 1 and higher (2) User 2 and higher (S) Service</p>				
4.3.2.1		Same as menu no. 3: • Call-up of settings for setpoints 1-3 • Call-up of external setpoint	-	-
4.3.2.2 (p-c)		• Entry of permitted limit values of controlled variable. A time delay until alarm triggers can be entered for these limit values.	(Z) P-Max. [bar]: 0.0 to sensor max (Z) P-Min [bar]: 0.0 to P-Max (Z) P-Hysteresis [bar]: 0.0 to 10.0 (Z) t-Hysteresis [s]: 0 to 60	10.0 bar 0.0 bar 0.0 bar 5 s
4.3.2.2 (T-c)		• Entry of permitted limit values of controlled variable. A time delay until alarm triggers can be entered for these limit values.	(Z) T-Max. [°C]: -272.0 to 999.9 (Z) T-Min. [°C]: -272.0 to 999.9 (Z) T-Hysteresis [°C]: 0.0 to 10.0 (Z) t-Hysteresis [s]: 0 to 60	50.0 °C 30.0 °C 0.0 °C 5 s
4.3.2.3 (p-c)		• Selection of sensor measuring range [1/2.5/4/6/8/10/16/25/40 bar] • Selection of system behaviour during sensor faults (switching off all pumps, operation of all pumps with max. speed or operation of a pump with pre-set speed) (see menu 4.3.5.1 page 2)	(Z) Measuring range [bar]: 16.0 (Z) Behaviour during sensor fault: Stop/Maximum/Variable	16.0 bar Stop

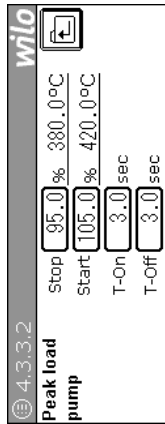
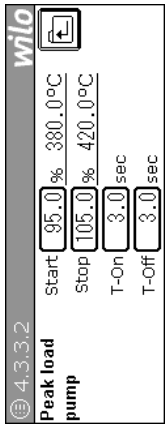
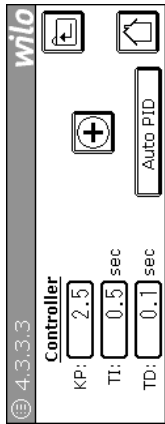
Menu no./ Called by:	Display	Description	Setting parameters/functions	Factory setting
	Visible for: (1) User 1 and higher (2) User 2 and higher (5) Service		Adjustable by: (1) User 1 and higher (2) User 2 and higher (5) Service	
4.3.2.3 (Δp -c, Δp -v) Sensor	(1) Sensor 	<ul style="list-style-type: none"> • Selection of sensor measuring range [2/10/20/40/60/100 m] • Selection of system behaviour during sensor faults (switching off all pumps, operation of all pumps with max. speed or operation of a pump with pre-set speed) (see menu 4.3.5.1 page 2) 	(2) Measuring range [m]: 20.0 (2) Behaviour during sensor fault: Stop/Maximum/Variable	20.0 m Stop
4.3.2.3 (ΔT -c, ΔT -v) Sensor	(1) Sensor 	<ul style="list-style-type: none"> • Selection of system behaviour during sensor faults (switching off all pumps, operation of all pumps with max. speed or operation of a pump with pre-set speed) (See menu 4.3.5.1 page 2) 	(2) Behaviour during sensor fault: Stop/Maximum/Variable	Stop
4.3.2.3 (T-c) Sensor	(1) Sensor 	<ul style="list-style-type: none"> • Selection of system behaviour during sensor faults (switching off all pumps, operation of all pumps with max. speed or operation of a pump with pre-set speed). • T_{Max} and T_{Min} define the limits of the sensor range for T-c via analogue input 1. (See menu 4.3.5.1 page 2) 	(2) T _{max} [°C]: -272 to 999.0 (2) T _{min} [°C]: -272 to 999.0 (2) Behaviour during sensor fault: Stop/Maximum/Variable	80.0 °C 40.0 °C Stop
4.3.2.3 (ΔT -c, ΔT -v, T-c) 	(1) Status of temperature sensor 	<ul style="list-style-type: none"> • Display status of temperature module, the temperature sensors (Tvl, Trl, Ta, Tp) and the recorded temperature Tvl: Feed temperature Trl: Return temperature Ta: Outdoor temperature Tp: Process temperature 	-	-

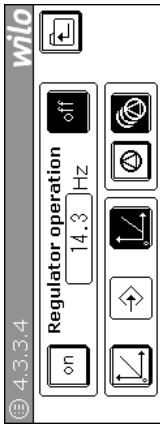

Menu no./	Display	Description	Setting parameters/functions	Factory setting
<p>Called by:</p> <ul style="list-style-type: none"> (1) User 1 and higher (2) User 2 and higher (5) Service 	<p>Adjustable by:</p> <ul style="list-style-type: none"> (1) User 1 and higher (2) User 2 and higher (5) Service 			
<p>4.3.2.4</p>	<p>(1) SxM logic</p> 	<ul style="list-style-type: none"> • Selection of mode of action of relay for the collective run signal (SBM) and collective fault signal (SSM). <p>Operation: </p> <p>Standby: </p> <p>(NC) Falling edge: </p> <p>(NO) Rising edge: </p>	<p>(2) SBM: Operation / standby</p> <p>(2) SSM: NC/NO</p>	<p>Operation</p> <p>NC</p>
<p>4.3.2.5</p>	<p>(1) Frost protection</p> 	<ul style="list-style-type: none"> • Selection of the type of frost protection acknowledgement. <p>Acknowledgement is required: </p> <p>Automatic acknowledgement: </p>	<p>(1) Acknowledgement: Manual / Auto</p>	<p>Auto</p>
<p>4.3.3</p>	<p>(1) Controller parameters</p> 	<ul style="list-style-type: none"> • Call-up of menu for setting the parameters of peak-load pump cut-in, the PID controller and control mode. 	<p>–</p>	<p>–</p>

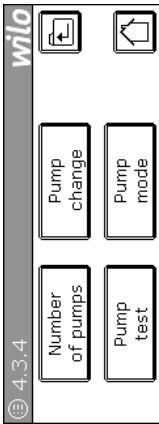
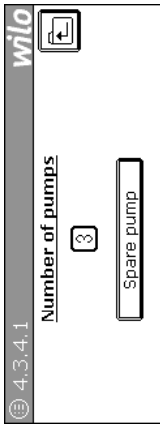
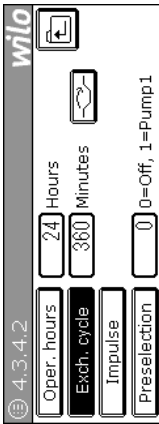
Menu no./	Display	Description	Setting parameters/functions	Factory setting
Called by: (1) User 1 and higher (2) User 2 and higher (S) Service				
Adjustable by: (1) User 1 and higher (2) User 2 and higher (S) Service				
4.3.3.2	(1) Peak-load pump 	<ul style="list-style-type: none"> • Display/setting of start-up and switch-off pressure. • Display/setting of the start-up and switch-off delays of the peak-load pumps (all values entered as % of 1st setpoint of controlled variable). 	(2) Stop [%]: 75.0 to 99.0 (2) Start [%]: 101.0 to 125.0 (2) T-on [s]: 1 to 60 (2) T-off [s]: 1 to 60	90.0 % 110.0 % 3 s 3 s
4.3.3.2	(1) Peak-load pump $(\Delta p-c, \Delta p-v)$ Positive effective direction 	<ul style="list-style-type: none"> • Display/setting of start-up and switch-off pressure. • Display/setting of the start-up and switch-off delays of the peak-load pumps (all values entered as % of 1st setpoint of controlled variable). 	(2) Stop [%]: 75.0 to 99.0 (2) Start [%]: 101.0 to 125.0 (2) T-on [s]: 1 to 60 (2) T-off [s]: 1 to 60	90.0 % 110.0 % 3 s 3 s
4.3.3.2	(1) Peak-load pump $(\Delta T-c, \Delta T-v)$ Negative effective direction 	<ul style="list-style-type: none"> • Display/setting of start-up and switch-off pressure. • Display/setting of the start-up and switch-off delays of the peak-load pumps (all values entered as % of 1st setpoint of controlled variable). 	(2) Stop [%]: 75.0 to 99.0 (2) Start [%]: 101.0 to 125.0 (2) T-on [s]: 1 to 3600 (2) T-off [s]: 1 to 3600	90.0 % 105.0 % 120 s 120 s

Menu no./	Display	Description	Setting parameters/functions	Factory setting
<p>Called by:</p> <p>(1) User 1 and higher (2) User 2 and higher (S) Service</p>	<p>Visible for:</p> <p>(1) User 1 and higher (2) User 2 and higher (S) Service</p>	Adjustable by:	Adjustable by:	
4.3.3.2	<p>(1) Peak-load pump</p> 	<ul style="list-style-type: none"> • Display/setting of start-up and switch-off pressure. • Display/setting of the start-up and switch-off delays of the peak-load pumps (all values entered as % of 1st setpoint of controlled variable). 	<p>(2) Stop [%]: 75.0 to 99.0</p> <p>(2) Start [%]: 101.0 to 125.0</p> <p>(2) T-on [s]: 0.1 to 240</p> <p>(2) T-off [s]: 0.1 to 240</p>	<p>90.0 %</p> <p>110.0 %</p> <p>3 s</p> <p>3 s</p>
4.3.3.2	<p>(1) Peak-load pump</p> 	<ul style="list-style-type: none"> • Display/setting of start-up and switch-off pressure • Display/setting of the start-up and switch-off delays of the peak-load pumps (all values entered as % of 1st setpoint of controlled variable). 	<p>(2) Stop [%]: 101.0 to 125.0</p> <p>(2) Start [%]: 75.0 to 99.0</p> <p>(2) T-on [s]: 1 to 3600</p> <p>(2) T-off [s]: 1 to 3600</p>	<p>110.0 %</p> <p>90.0 %</p> <p>120 s</p> <p>120 s</p>
4.3.3.3	<p>(1) PID controller</p> 	<ul style="list-style-type: none"> • Setting of proportional value, integral time, derivative time and controller effective direction for the PID controller. Positive effective direction:  (T-c only) Negative effective direction:  (T-c only) 	<p>(2) KP: 0.1 to 999.9</p> <p>(2) TI [s]: 0.1 to 3000.0</p> <p>(2) TD [s]: 0.1 to 10.0</p> <p>(S) AutoPID</p>	<p>2.5</p> <p>0.5 s</p> <p>0.1 s</p>

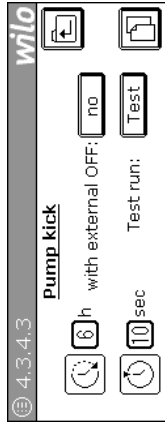
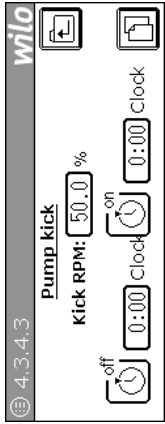
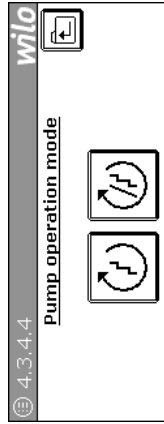
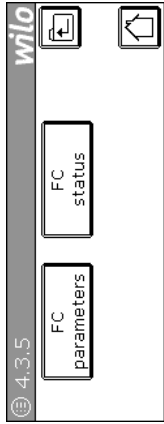
Menu no./	Display	Description	Setting parameters/functions	Factory setting
<p>Called by: (1) User 1 and higher (2) User 2 and higher (S) Service</p> <p>Adjustable by: (1) User 1 and higher (2) User 2 and higher (S) Service</p>				
4.3.3.4		<p>(1) Manual control mode</p> <ul style="list-style-type: none"> Activation of manual control mode and selection of signal type (0 to 20 mA or 4 to 20 mA). Display of external frequency setpoint. <p>This operating mode can be used on (CCe only):  or on all pumps: </p>	<p>(2) Manual control mode: on/off</p> <p>(2) Signal type: 0 to 20 mA / 4 to 20 mA</p> <p>(2) Single/multi-pump operation: S/M</p>	<p>off</p> <p>4 to 20 mA</p> <p>M</p>
4.3.4		<p>(1) Pump parameters</p> <ul style="list-style-type: none"> Call-up of menus for setting the number of pumps (CCe only) Call-up of the parameters for pump cycling or the pump test run, and the pump operating mode (CCe only) 	<p>–</p>	<p>–</p>
4.3.4.1		<p>(1) Number of pumps</p> <ul style="list-style-type: none"> Setting the number of pumps of the system Defining operation with or without standby pump 	<p>(2) Number of pumps: 1 to 6</p> <p>(2) Standby pump: With/Without</p>	<p>3</p> <p>Without</p>
4.3.4.2		<p>(1) Pump cycling</p> <ul style="list-style-type: none"> Specification of type of pump cycling (acc. to operating hours, at switch-on pulse, cyclical) and the cycling times. It is possible to permanently set the base-load pump. To do so, the number of this pump must be entered. For cyclical pump cycling there is the option of switching on a duty change-over pump.  	<p>(2) Operating hours [h]: 1 to 99</p> <p>(2) Exchange cycle [min]: 1 to 1440</p> <p>(2) Number of permanently set pump: 0 to (system-specific)</p> <p>(2) Overlapping SLP: Off/On</p>	<p>24 h</p> <p>360 min</p> <p>0</p> <p>Off</p>

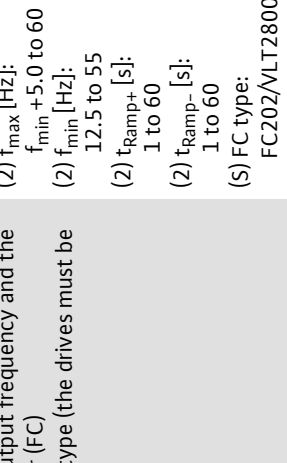
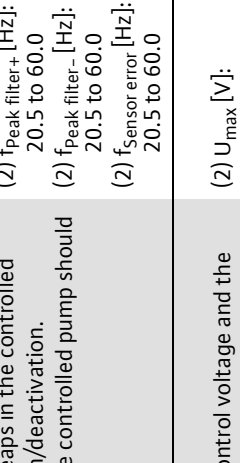

Menu no./	Display	Description	Setting parameters/functions	Factory setting
<p>Called by: (1) User 1 and higher (2) User 2 and higher (5) Service</p> <p>Adjustable by: (1) User 1 and higher (2) User 2 and higher (5) Service</p>				
4.3.4.3		<p>(1) Pump test run (page 1 of 2)</p> <ul style="list-style-type: none"> Setting of pump test run interval and of the activation period during the pump test run Selection of whether test run should also happen with external Off Option of pump test if drives are OFF (menu 4.3.1): Pressing the 'TEST' button starts one pump for the duration set above. Every subsequent pressing of the button starts the additional pumps in sequence. 	<p>(2) Test run interval [h]: 0 to 99</p> <p>(2) Activation period [s]: 1 to 30</p> <p>(2) With external Off: No/Yes</p> <p>(2) Test run (only possible when drives Off)</p>	<p>6 h</p> <p>10 s</p> <p>Yes</p> <p>–</p>
4.3.4.3		<p>(1) Pump test run (page 2 of 2)</p> <ul style="list-style-type: none"> Determining the speed for pump test run (CCe and CC...FC only) Specifying a period without pump test run, 00:00 – 00:00 deactivates the function 	<p>(2) Test run speed [%]: 0.1 to 100.0</p> <p>(2) Start of period without test run: 00:00 to 23:59</p> <p>(2) End of period without test run: 00:00 to 23:59</p>	<p>100.0 %</p> <p>00:00</p> <p>00:00</p>
4.3.4.4		<p>(1) Pump operating mode</p> <ul style="list-style-type: none"> Setting the Cascade or Vario operating mode (CCe only) 	<p>(2) Mode: Cascade/Vario</p>	<p>Vario</p>
4.3.5		<p>(1) Frequency converter (FC)</p> <ul style="list-style-type: none"> Call-up of menus for setting the FC parameters Call-up of menus for displaying the FC status 	<p>–</p>	<p>–</p>

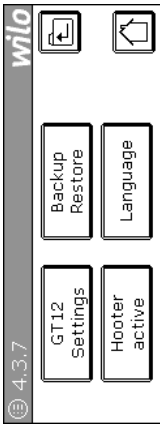
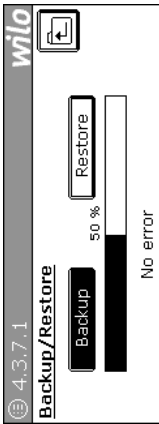
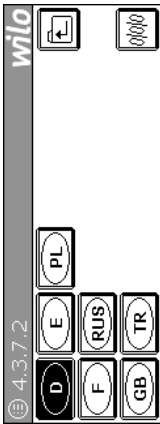
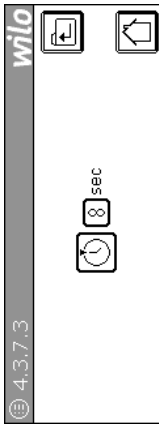

Menu no./	Display	Description	Setting parameters/functions	Factory setting
<p>Called by: (1) User 1 and higher (2) User 2 and higher (S) Service</p> <p>Adjustable by: (1) User 1 and higher (2) User 2 and higher (S) Service</p>				
4.3.5.1	<p>(1) FC parameters (page 1 of 2)</p>  <p>FC Parameter</p>	<ul style="list-style-type: none"> Setting the maximum and minimum output frequency and the ramp times of the frequency converter (FC) Determining the frequency converter type (the drives must be switched off for this) 	<p>(2) f_{max} [Hz]: $f_{min} +5.0$ to 60</p> <p>(2) f_{min} [Hz]: 12.5 to 55</p> <p>(2) t_{ramp+} [s]: 1 to 60</p> <p>(2) t_{ramp-} [s]: 1 to 60</p> <p>(S) FC type: FC202/VLT2800/VLT600</p>	<p>50 Hz</p> <p>35 Hz</p> <p>5 s</p> <p>5 s</p> <p>FC202</p>
4.3.5.1	<p>(1) FC parameters (page 2 of 2)</p>  <p>FC Parameter</p>	<ul style="list-style-type: none"> Setting of FC frequencies to prevent leaps in the controlled variable during peak-load pump cut-in/deactivation. Setting of FC frequency with which the controlled pump should run during sensor fail. 	<p>(2) $f_{peak\ filter+}$ [Hz]: 20.5 to 60.0</p> <p>(2) $f_{peak\ filter-}$ [Hz]: 20.5 to 60.0</p> <p>(2) $f_{sensor\ error}$ [Hz]: 20.5 to 60.0</p>	<p>50 Hz</p> <p>35 Hz</p> <p>40 Hz</p>
4.3.5.1	<p>(1) FC parameters (page 1 of 2)</p>  <p>FC Parameter</p>	<ul style="list-style-type: none"> Setting the maximum and minimum control voltage and the ramp times for electronic pumps. 	<p>(2) U_{max} [V]: 8.0 to 10.0</p> <p>(2) U_{min} [V]: 0 to 7</p> <p>(2) t_{ramp+} [s]: 0.0 to 60.0</p> <p>(2) t_{ramp-} [s]: 0.0 to 60.0</p>	<p>10.0 V</p> <p>0.0 V</p> <p>0.0 s</p> <p>0.0 s</p>

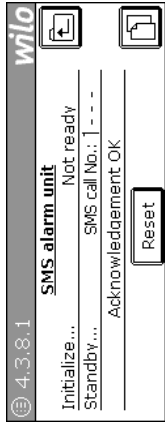
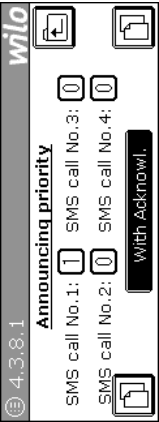
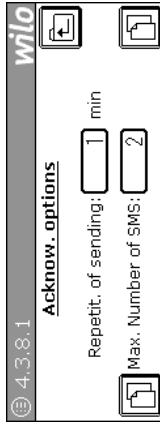
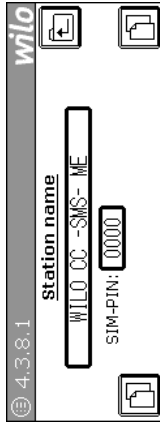
Menu no./	Display	Description	Setting parameters/functions	Factory setting
<p>Called by: (1) User 1 and higher (2) User 2 and higher (5) Service</p>				
<p>Adjustable by: (1) User 1 and higher (2) User 2 and higher (5) Service</p>				
4.3.5.1		<ul style="list-style-type: none"> Setting of FC frequency with which the base-load pump should run during sensor fail. 	(2) $f_{\text{sensor error}}$ [%]: 0.1 to 100.0	80.0 %
4.3.5.2		<ul style="list-style-type: none"> Display of status signals of the bus connection and frequency converter (FC). 	–	–
4.3.5.2		<ul style="list-style-type: none"> Display of warning signals from the frequency converter (FC) (voltage, current, temperature). 	–	–
4.3.6		<ul style="list-style-type: none"> Setting of real-time clock (time, date) as well as day of the week: 1=Monday, 2 = Tuesday ... to 0 = Sunday 	<ul style="list-style-type: none"> Time of day [hh:mm:ss] Date [dd.mm.yy] Day of the week 	– – –

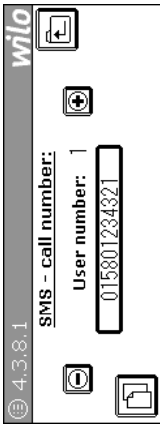
Menu no./	Display	Description	Setting parameters/functions	Factory setting
Called by: (1) User 1 and higher (2) User 2 and higher (S) Service				
Adjustable by: (1) User 1 and higher (2) User 2 and higher (S) Service				
4.3.7		(1) Display settings <ul style="list-style-type: none"> • Activation/deactivation of horn (during fault signals) • Call-up of sub-menu for setting of the display (brightness and contrast – these are system screens, not shown here) • Call-up of sub-menu for backup/restore • Call-up of sub-menu to set the language 	(2) Horn: Off/On	Off
4.3.7.1		(2) Backup/Restore <ul style="list-style-type: none"> • Possibility of saving (backing up) or restoring recipes (PLC parameter sets) to/from the memory of the display. The drives must be switched off for this. 	(2) Backup (S) Restore	- -
4.3.7.2		(1) Language <ul style="list-style-type: none"> • Specification of active language for display texts. 	(1) Language	German
4.3.7.3		(1) Language parameters <ul style="list-style-type: none"> • Setting the display duration for language selection after system start. 	(2) Display duration [s]: 0 to 30	10 s

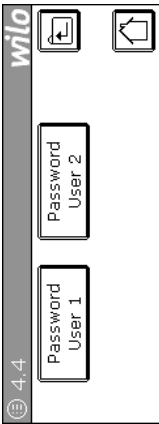
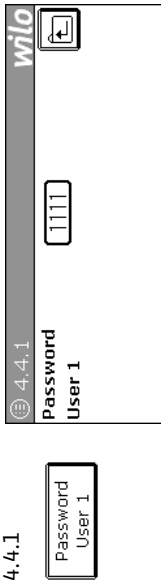
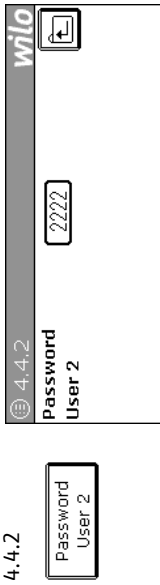
Menu no./	Display	Description	Setting parameters/functions	Factory setting
Called by:	Visible for: (1) User 1 and higher (2) User 2 and higher (5) Service		Adjustable by: (1) User 1 and higher (2) User 2 and higher (5) Service	
4.3.8.1	 <p>4.3.8.1 SMS alarm unit Initialize... Not ready Standby... SMS call No.: - - - Acknowledgement OK Reset</p>	<ul style="list-style-type: none"> Display of text message notification status, readiness to receive data, text message send status, text message receiver, acknowledgement status. <p>Local reset of fault signals: <input type="button" value="Reset"/></p>	(2) Reset	-
4.3.8.1	 <p>4.3.8.1 Announcing priority SMS call No.1: 1 SMS call No.3: 0 SMS call No.2: 0 SMS call No.4: 0 With Acknowl.</p>	<ul style="list-style-type: none"> Specification of priority (0 to 4) for the 4 possible phone numbers. Specification of acknowledgement requirement 	(2) Priority of phone number 1: 0 to 1 to 4 (2) Priority of phone number 2: 0 to 4 (2) Priority of phone number 3: 0 to 4 (2) Priority of phone number 4: 0 to 4	1 0 0 0
4.3.8.1	 <p>4.3.8.1 Acknow. options Repetit. of sending: 1 min Max. Number of SMS: 2</p>	<ul style="list-style-type: none"> Setting of time for transmission repetition and the maximum number of text messages per event and phone number. <p>Note: This page is only displayed if 'With acknowledgement' was specified on page 2.</p>	(2) Transmission repetition time [min]: 1 to 999 (2) Max. number of text messages: 1 to 10	1 2
4.3.8.1	 <p>4.3.8.1 Station name WIL0 DC - SMS- ME SIM-PIN: 0000</p>	<ul style="list-style-type: none"> Entry of station name for telemetry Entry of SIM PIN for the SIM card. 	(2) Station name [text, 16 characters] (2) PIN [numerical, 4 digits]	System-specific System-specific

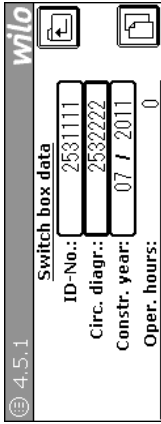
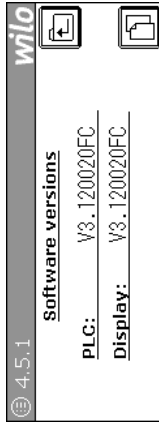
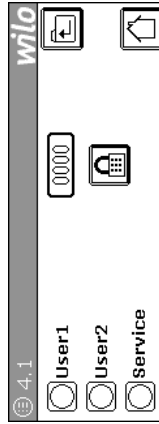
Menu no./	Display	Description	Setting parameters/functions	Factory setting
Called by: (1) User 1 and higher (2) User 2 and higher (S) Service				
Adjustable by: (1) User 1 and higher (2) User 2 and higher (S) Service				
4.3.8.1		(1) Text message setting (page 5 of 5) • Entry of 4 possible phone numbers (participant no. 1-4) • Entry of number of text message centre of provider (participant no. 5). Scrolling of participant list: Upwards:  Downwards: 	(2) Phone number 1-5 [numerical, 16 characters]	System-specific
4.4		(1) Password menu • Call-up of sub-menu to specify passwords for USER1 and USER2	–	–
4.4.1		(1) Password User 1 • Entry of password for USER1	(1) Password User 1: [numerical, 4 digits]	1111
4.4.2		(2) Password User 2 • Entry of password for USER2	(2) Password User 2: [numerical, 4 digits]	2222

Menu no./	Display	Description	Setting parameters/functions	Factory setting
	<p>Visible for: (1) User 1 and higher (2) User 2 and higher (S) Service</p>		Adjustable by: (1) User 1 and higher (2) User 2 and higher (S) Service	
4.5		(1) Switchgear info <ul style="list-style-type: none"> • Display of switchgear designation • Call-up of switchgear data • Call-up of software versions 	–	–
4.5.1		(1) Switchgear data (page 1 of 2) <ul style="list-style-type: none"> • Entry/display of ID number, wiring diagram number and construction year of switchgear. • Display of operating hours of switchgear. 	(S) ID no. [text, 10 characters] (S) Wiring diagram number [text, 10 characters] (S) Construction year [month/year]	System-specific – –
4.5.1		(1) Switchgear data (page 2 of 2) <ul style="list-style-type: none"> • Display of software versions of the PLC program. • Display of the touch display program. 	–	–
4.5.2		(1) Login/logout <p>Same as 4.1:</p> <ul style="list-style-type: none"> • Entry of password for login (User1, User2, Service) • Display of login status • Logout possible by pressing the login symbol Logout: 	Password entry	–

7 Installation and electrical connection

Safety



DANGER! Risk of fatal injury!

There is a risk of fatal injury from electric shock when working on electrical equipment.

- **Danger from electrical current must be eliminated.**
- **Local directives or general directives [e.g. IEC, VDE etc.] and instructions from local energy supply companies must be adhered to.**



DANGER! Risk of fatal injury!

Incorrect installation and improper electrical connections can be life-threatening.

- **Have the electrical connections set up by qualified electricians only, in compliance with the applicable regulations.**
- **Adhere to accident prevention regulations.**

7.1 Installation

Wall-mounted installation (WM):

- Secure the wall unit using 4 screws \varnothing 8 mm. The protection class is to be ensured using suitable measures.

Floor model, BM (base mounted):

- The floor model is set up free-standing on a level surface (with sufficient bearing capacity). An up-right panel support with a height of 100 mm is provided for the cable inlet as standard. Other supports are available on request.

7.2 Electrical connection

Safety



DANGER! Risk of fatal injury!

Incorrect electrical connections can cause fatal electric shocks.

- **Have the electrical connection set up by an electrician approved by the local electricity supplier only and in accordance with local regulations.**
- **Observe the installation and operating instructions for the accessories.**

Mains connection



DANGER! Risk of fatal injury!

There is a potentially fatal voltage on the supply side, even when the main switch is switched off.

- **Observe general safety instructions!**

The mains type, current type and voltage of the mains connection must match the details on the rating plate of the control device.

Mains requirements



NOTE:

See following list "Table 11: System impedances and switching cycles" on page 108: In accordance with DIN EN / IEC 61000-3-11, the switchgear and pump with a power of ... kW (column 1) are intended for operation on a mains power supply with a system impedance Z_{\max} at the building connection of max. ... Ω (column 2) for a maximum number of ... connections per hour (column 3).

If the mains impedance and the number of connections per hour are greater than the values specified in the table, the switchgear with the pump may lead to temporary voltage drops and also to disruptive voltage fluctuations (flickering) due to the unfavourable mains conditions.

Therefore, measures may be necessary before the switchgear with pump can be operated as intended on this connection. The necessary information must be obtained from the local energy supply company and the manufacturer.

	Column 1: Power [kW]	Column 2: System impedance [Ω]	Column 3: Connections per hour
3~400 V 2-pole Direct starting	2.2	0.257	12
	2.2	0.212	18
	2.2	0.186	24
	2.2	0.167	30
	3.0	0.204	6
	3.0	0.148	12
	3.0	0.122	18
	3.0	0.107	24
	4.0	0.130	6
	4.0	0.094	12
	4.0	0.077	18
	5.5	0.115	6
	5.5	0.083	12
	5.5	0.069	18
	7.5	0.059	6
	7.5	0.042	12
	9.0 – 11.0	0.037	6
	9.0 – 11.0	0.027	12
	15.0	0.024	6
	15.0	0.017	12
3~400 V 2-pole S-D starting	5.5	0.252	18
	5.5	0.220	24
	5.5	0.198	30
	7.5	0.217	6
	7.5	0.157	12
	7.5	0.130	18
	7.5	0.113	24
	9.0 – 11.0	0.136	6
	9.0 – 11.0	0.098	12
	9.0 – 11.0	0.081	18
	9.0 – 11.0	0.071	24
	15.0	0.087	6
	15.0	0.063	12
	15.0	0.052	18
	15.0	0.045	24
	18.5	0.059	6
	18.5	0.043	12
	18.5	0.035	18
	22	0.046	6
	22	0.033	12
22	0.027	18	
30	0.027	6	
30	0.020	12	
30	0.016	18	
37	0.018	6	
37	0.013	12	
45	0.014	6	
45	0.010	12	

Table 11: System impedances and switching cycles



NOTE:

The maximum number of connections per hour specified in the table for each power is determined by the pump motor and must not be exceeded (adjust the parameterisation of the controller accordingly; see follow-up times, for example).

- Provide fuse protection on the mains side in accordance with the information in the wiring diagram.
- Feed the ends of the mains cable through the threaded cable connections and cable inlets. Wire the cable ends according to the markings on the terminal strips.
- The 4-wire cable (L1, L2, L3, PE) is to be provided onsite. The connection is made at the main switch (fig. 1a-e, item 1) or for systems of higher power at the terminal strips in accordance with the wiring diagram. The PE is to be connected to the earth rail.

Pump mains connections



CAUTION! Risk of property damage!
Risk of damage due to incorrect handling.

- **Observe the installation and operating instructions for the pumps.**

Power connection

- The pumps must be connected to the terminal strips in accordance with the wiring diagram. The PE is to be connected to the earth rail. Use shielded motor cables.

Connecting cable shields to the EMC threaded cable connections (CC... WM): See fig. 16, steps 1 to 3.

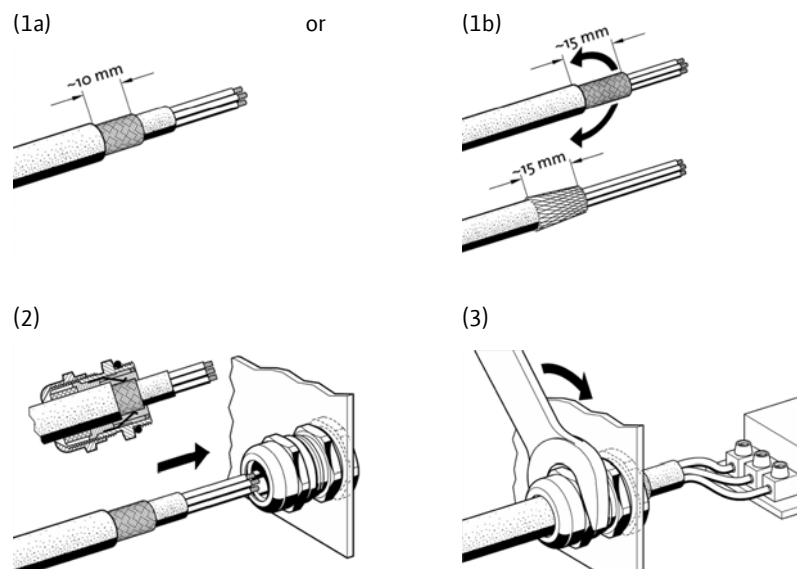

Fig. 16: Connecting cable shields to the EMC threaded cable connections

Connecting cable shields to the shield clamps (CC... BM), see fig. 16, steps 1 to 4.



NOTE:
The length of the cut (see fig. 17, step 3) must be matched exactly to the width of the clamp used.



NOTE:
If the pump connection cables are extended beyond the dimension supplied ex-works, it is necessary to comply with the EMC information in the operating manual for the frequency converter (CC...FC version only).

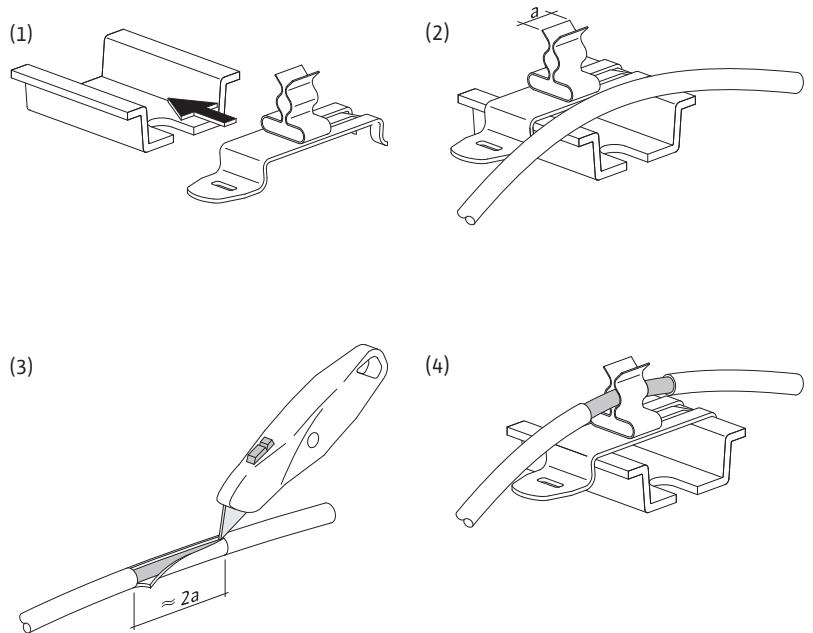

Fig. 17: Connecting cable shields to the shield clamps (CC... BM)

Connection of excess temperature protection/pump fault

- The thermal winding contacts or fault signal contacts (CCe version) on the pumps can be connected to the terminals in accordance with the wiring diagram.



CAUTION! Risk of property damage!
Risk of damage due to incorrect connection.

- **Do not connect any external voltage to the terminals!**

Connection of pump control signal (CCe version only)

- The analogue control signals for the pumps (0–10 V) can be connected to the terminals in accordance with the wiring diagram.
- Use shielded cables.



CAUTION! Risk of property damage!
Risk of damage due to incorrect connection.

- **Do not connect any external voltage to the terminals!**

Sensors

- Connect the sensors correctly to the terminals according to the wiring diagram in the installation and operating instructions.
- Use a shielded cable, place the shield on one side in the switchbox.



CAUTION! Risk of property damage!
Risk of damage due to incorrect connection.

- **Do not connect any external voltage to the terminals!**

Analogue IN, external setpoint/control mode

- Remote adjustment of the speed setpoint or control mode via an analogue signal (0/4 to 20 mA or 0/2 to 10 V) are possible using corresponding terminals in accordance with the wiring diagram.
- Use a shielded cable, place the shield on one side in the switchbox.

Setpoint changeover

- Using the corresponding terminals in accordance with the wiring diagram, it is possible to force a changeover from setpoint 1 to setpoint 2 or 3 using a potential-free contact (normally open contact).

**CAUTION! Risk of property damage!****Risk of damage due to incorrect connection.**

- **Do not connect any external voltage to the terminals!**

Logic diagram		
Contact		Function
Setpoint 2	Setpoint 3	
Contact opened	Contact opened	Setpoint 1 active
Contact closed	Contact opened	Setpoint 2 active
Contact opened	Contact closed	Setpoint 3 active
Contact closed	Contact closed	Setpoint 3 active

Table 12: Logic diagram for setpoint changeovers

External activation/deactivation

- Using the corresponding terminals in accordance with the wiring diagram, it is possible to connect a remote activation/deactivation by means of a potential-free contact (normally closed contact) after removing the jumper (factory-fitted).

**CAUTION! Risk of property damage!****Risk of damage due to incorrect connection.**

- **Do not connect any external voltage to the terminals!**

External activation/deactivation	
Contact closed:	Automatic ON
Contact open:	Automatic OFF Signal by symbol on the display
Contact load:	24 V DC / 10 mA

Table 13: External activation/deactivation

Frost protection (not with p-c)

- Using the corresponding terminals (in accordance with the wiring diagram), it is possible to connect a frost monitor by means of a potential-free contact (normally closed contact).

**CAUTION! Risk of property damage!****Risk of damage due to incorrect connection.**

- **Do not connect any external voltage to the terminals!**

Frost protection	
Contact closed:	Automatic mode
Contact open:	Frost alarm Frost protection function is activated
Contact load:	24 V DC / 10 mA

Table 14: Logic diagram for frost protection

**Protection against low water level
(for p-c only)**

- Using the corresponding terminals (in accordance with the wiring diagram), it is possible to connect a function for protection against low water level by means of a potential-free contact (normally closed contact) after removing the jumper (factory-fitted).



CAUTION! Risk of property damage!
Risk of damage due to incorrect connection.

- **Do not connect any external voltage to the terminals!**

Protection against low water level	
Contact closed:	Automatic mode
Contact open:	Low water
Contact load:	24 V DC / 10 mA

Table 15: Logic diagram for protection against low water level

Collective run/collective fault signals

- Potential-free contacts (changeover contacts) for external signals are available via the corresponding terminals in accordance with the wiring diagram. Potential-free contacts, max. contact load 250 V~/2 A



DANGER! Risk of fatal injury!
There can be a potentially fatal voltage on these terminals, even when the main switch is switched off.

- **Observe general safety instructions!**

Display of controlled variable actual value

Using the corresponding terminals in accordance with the wiring diagram, a 0 to 10 V signal for an external measurement/display option for the current controlled variable actual value is available. The following equivalents apply depending on the control mode:

- The 0 to 10 V signal corresponds to the sensor signal 0 to sensor final value
- or**
- In temperature control modes, the 0 to 10 V signal corresponds to particular limits

for example (see "Table 16: Actual value display examples" on page 112):

Control mode	Sensor	Display pressure range	Voltage/measured variable
p-c	Pressure sensor kit, 16 bar	0 to 16 bar	1 V = 1.6 bar
Δp-...	Differential pressure sensor 40	0 to 40 m (water column)	1 V = 4 m (water column)
ΔT-...	-	0 to 100 K	1 V = 10 K
n = f(T...)	-	0 to 100 °C	1 V = 10 °C
Tvl-c, Trl-c, Ta-c, Tp-c	-	0 to 500 °C	1 V = 50 °C
Tai-c	-	T _{min} ... T _{max}	-

Table 16: Actual value display examples



CAUTION! Risk of property damage!
Risk of damage due to incorrect connection.

- **Do not connect any external voltage to the terminals!**

Actual frequency display

For switchgear with frequency converter (CC...FC only), a 0 to 10 V signal for an external measuring/display option for the current actual frequency of the base-load pump is available via the corresponding terminals in accordance with the wiring diagram.

0 to 10 V corresponds to the frequency range 0 to f_{\max} .



CAUTION! Risk of property damage!
Risk of damage due to incorrect connection.

- **Do not connect any external voltage to the terminals!**



NOTE:

The information for installation and for electrical connection of optional inputs/outputs can be found in the installation and operating instructions for these modules.

8 Commissioning

DANGER! Risk of fatal injury!
Improper commissioning poses a risk of fatal injury.

- **Have commissioning performed by qualified personnel only.**



DANGER! Risk of fatal injury!
When working on the open switchgear, there is a danger of electric shock from touching the live components.

- **The work must only be carried out by qualified personnel.**

It is recommended that you have the switchgear commissioned by Wilo customer service.

- Before switching on for the first time, check the onsite wiring for correct connection, particularly correct earthing.



NOTE:

Tighten all connection terminals before the commissioning!



NOTE:

In addition to the activities described in these installation and operating instructions: Perform the commissioning measures in accordance with the relevant installation and operating instructions for the pumps and sensors.

8.1 Factory setting

The control system is preset in the factory.

The factory settings can be restored by Wilo customer service.

8.2 Checking the motor direction of rotation

- By briefly switching on each pump in “Manual mode” (menu 1.1), check whether the direction of rotation of the pump in mains operation corresponds to the arrow on the pump housing.

For glandless pumps the correct or incorrect direction of rotation is shown by an indicator LED in the terminal box (see installation and operating instructions for the pump).

- If the direction of rotation of **all** pumps in mains operation is incorrect, swap over any 2 live wires in the main mains cable.

Switchgear without frequency converter (CC version):

- If the direction of rotation of only one pump in mains operation is incorrect (for direct starting motors): Swap over any 2 live wires in the motor terminal box.
- If the direction of rotation of only one pump in mains operation is incorrect (for star-delta starting motors): Swap over 4 connections in the motor terminal box – for each of 2 live wires swap over the start and end of the winding (for example swap V_1 with V_2 and W_1 with W_2).

Switchgear with frequency converter (CC...FC):

- Mains operation: Set each pump to “Manual mode” individually in menu 1.1. Then proceed in the same way as for switchgear without frequency converter.
- Frequency converter mode: In automatic mode with frequency converter, set each pump individually to “Automatic” in menu 1.1. The direction of rotation in frequency converter mode is then checked by briefly switching on the individual pumps. If the direction of rotation of all pumps is incorrect, swap over any 2 live wires at the frequency converter output.

8.3 Adjusting the motor protection

- **Thermal winding contact/PTC:** No adjustment is required for the excess temperature protection.
- **Excess current:** See chapter 6.2.3 “Motor protection” on page 72.

8.4 Signal transmitters and optional modules

Observe the installation and operating instructions for signal transmitters and optional additional modules.

9 Maintenance

Have maintenance and repair work carried out by qualified personnel only!



DANGER! Risk of fatal injury!

There is a risk of fatal injury from electric shock when working on electrical equipment.

- **The switchgear must be isolated from the voltage and secured to prevent it from being switched back on before any maintenance or repair work.**
- **Any damage to the connection cable should always be rectified by a qualified electrician only.**
- Keep the switch cabinet clean.
- Clean the switch cabinet and fans if they are dirty. Check the filter mats in the fans, clean them and replace them if they are excessively dirty.
- If the motor power is 5.5 kW or more, check the contactors for burn-out from time to time (for example at the normal service intervals). If there is severe burn-out, replace the contactor contacts.
- The charge level of the real time clock backup battery is registered by the system and reported, if necessary. In addition, we recommend replacing it every 12 months. To do this, replace the battery in the CPU assembly (see fig. 18).

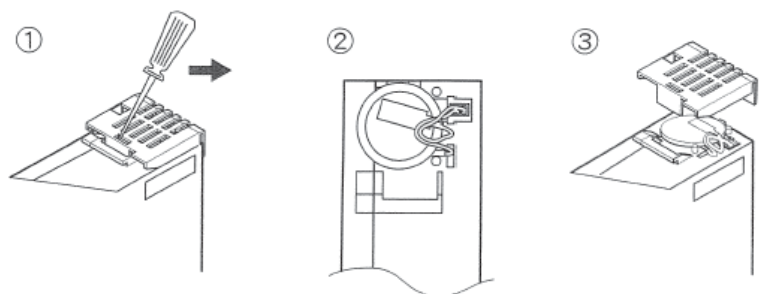

Fig. 18: Replacing the battery in the CPU assembly

10 Faults, causes and remedies

Have faults remedied by qualified personnel only! Observe the safety instructions in chapter 2 "Safety" on page 61.

- **If the fault cannot be remedied, contact your nearest Wilo customer service point or representative.**

10.1 Fault display and acknowledgement

If a fault occurs, the background colour of the touch display turns RED, the collective fault signal is activated and the fault is displayed in menu 4.2 with fault code number and alarm text.

A signal is sent to the defined recipient(s) for systems equipped with remote diagnostics. The fault can be acknowledged in menu 4.2 using the "RESET" button or by remote diagnostics.

If the cause of the fault is removed before acknowledgement, the background colour of the touch display changes to GREEN. If the fault remains, the background colour changes to ORANGE.

A faulty pump is indicated on the main screen by a flashing pump symbol.

10.2 History memory for faults

A history memory has been set up for the switchgear and operates according to the FIFO principle (first in, first out). The memory is configured for 35 faults.

The alarm list (menu 4.2.1) can be called up from menu 4.2. Within the list, the signals can be called up using the "+" and "-" buttons. The following list "Table 17: Fault signals, causes and remedies" on page 115 contains a list of all fault signals.

Code	Alarm text	Causes	Remedy
E040	Sensor faulty	Sensor defective	Replace sensor
		No electrical connection to the sensor	Repair the electrical connection
E060	Output pressure Max	The output pressure of the system has risen above the value set in menu 4.3.2.2 (for example due to a controller fault)	Check controller function. Check installation.
E061	Output pressure Min	The output pressure of the system has fallen below the value set in menu 4.3.2.2 (for example due to a pipe burst)	Check whether the set value corresponds to local conditions. Check the pipe and repair it if necessary.
E062	Low water	Protection against low water level has tripped	Check inlet/break tank; pumps restart automatically.
E064	Frost protection	Frost protection thermostat has tripped	Check the external temperature
E080.1 - E080.6	Pump 1 to 6 alarm	Excess winding temperature (thermal winding contact/PTC)	Clean the cooling fins; motors are designed for an ambient temperature of +40 °C (see also installation and operating instructions for the pump)
		Motor protection has tripped (excess current or short-circuit in the supply line)	Check the pump (in accordance with the installation and operating instructions for the pump) and the supply line
		Collective fault signal for the pump frequency converter has been activated (CCe version only)	Check the pump (in accordance with the installation and operating instructions for the pump) and the supply line

Table 17: Fault signals, causes and remedies

Code	Alarm text	Causes	Remedy
E082	FC Error	Frequency converter has signalled a fault	Read off fault in menu 4.3.5.2 or on frequency converter and act in accordance with frequency converter operating instructions
		Electrical connection disrupted	Check connection to frequency converter and repair if necessary.
		Motor protection for frequency converter has tripped (for example short-circuit of FC mains power cable; overload of the connected pump).	Check the mains power cable and repair it if necessary. Check the pump (in accordance with the installation and operating instructions for the pump).
E100	Battery error	The battery charge has decreased to the minimum level; further buffering of the real time clock is not guaranteed.	Replace battery (see chapter 9 "Maintenance" on page 114).

Table 17: Fault signals, causes and remedies

11 Spare parts

Spare parts may be ordered via a local specialist and/or Wilo customer service.

To avoid queries and incorrect orders, all data from the rating plate must be specified with every order.



CAUTION! Risk of property damage!

Trouble-free function of the product can only be guaranteed if genuine spare parts are used.

- **Use only genuine Wilo spare parts.**
- **Information to be provided when ordering spare parts:**
 - **Spare part number**
 - **Name/description of the spare part**
 - **All data from the rating plate**



NOTE:

For a list of genuine spare parts, see the Wilo spare parts documentation (www.wilo.com).

12 Disposal

Proper disposal and recycling of this product prevents damage to the environment and risks to personal health.

Disposal in accordance with the regulations requires the product to be drained and cleaned.

Lubricants must be collected. The components are to be separated according to material (metal, plastic, electronics).

1. Use public or private disposal organisations when disposing of all or part of the product.
2. For more information on proper disposal, please contact your local council or waste disposal office or the supplier from whom you obtained the product.



NOTE:

The product or any of its parts must not be disposed of with household waste.

For further information on recycling, visit www.wilo-recycling.com

Subject to change without prior notice.

D **EG – Konformitätserklärung**
GB **EC – Declaration of conformity**
F **Déclaration de conformité CE**

(gemäß 2004/108/EG Anhang IV,2 und 2006/95/EG Anhang III,B,
according 2004/108/EC annex IV,2 and 2006/95/EC annex III,B,
conforme 2004/108/CE appendice IV,2 et 2006/95/CE appendice III B)

Hiermit erklären wir, dass die Bauarten der Baureihe : **Wilo Control CC**
Herewith, we declare that this product:
Par le présent, nous déclarons que cet agrégat :

in der gelieferten Ausführung folgenden einschlägigen Bestimmungen entspricht:
in its delivered state complies with the following relevant provisions:
est conforme aux dispositions suivants dont il relève:

Elektromagnetische Verträglichkeit – Richtlinie **2004/108/EG**
Electromagnetic compatibility – directive
Compatibilité électromagnétique– directive

Niederspannungsrichtlinie **2006/95/EG**
Low voltage directive
Directive basse-tension

und entsprechender nationaler Gesetzgebung.
and with the relevant national legislation.
et aux législations nationales les transposant.

Angewendete harmonisierte Normen, insbesondere: **EN 50178, EN 60034-1, EN 60730-1,**
Applied harmonized standards, in particular: **EN 61000-6-2, EN 61000-6-3 < 22 kW,**
Normes harmonisées, notamment: **EN 61000-6-4 > 30 kW,**
EN 55011 + A2 Class A 22-30 kW

Bei einer mit uns nicht abgestimmten technischen Änderung der oben genannten Bauarten, verliert diese Erklärung ihre Gültigkeit.
If the above mentioned series are technically modified without our approval, this declaration shall no longer be applicable.
Si les gammes mentionnées ci-dessus sont modifiées sans notre approbation, cette déclaration perdra sa validité.

Dortmund, 17.08.2011

i. V. 
Erwin Prieß
Quality Manager

wilo

WILO SE
Nortkirchenstraße 100
44263 Dortmund
Germany

NL
EG-verklaring van overeenstemming
Hiermede verklaren wij dat dit aggregaat in de geleverde uitvoering voldoet aan de volgende bepalingen:
Elektromagnetische compatibiliteit 2004/108/EG
EG-laagspanningsrichtlijn 2006/95/EG
gebruikte geharmoniseerde normen, in het bijzonder:
zie vorige pagina

IT
Dichiarazione di conformità CE
Con la presente si dichiara che i presenti prodotti sono conformi alle seguenti disposizioni e direttive rilevanti:
Compatibilità elettromagnetica 2004/108/EG
Direttiva bassa tensione 2006/95/EG
norme armonizzate applicate, in particolare:
vedi pagina precedente

ES
Declaración de conformidad CE
Por la presente declaramos la conformidad del producto en su estado de suministro con las disposiciones pertinentes siguientes:
Directiva sobre compatibilidad electromagnética 2004/108/EG
Directiva sobre equipos de baja tensión 2006/95/EG
normas armonizadas adoptadas, especialmente:
véase página anterior

PT
Declaração de Conformidade CE
Pela presente, declaramos que esta unidade no seu estado original, está conforme os seguintes requisitos:
Compatibilidade electromagnética 2004/108/EG
Directiva de baixa voltagem 2006/95/EG
normas harmonizadas aplicadas, especialmente:
ver página anterior

SV
CE- försäkran
Härmed förklarar vi att denna maskin i levererat utförande motsvarar följande tillämpliga bestämmelser:
EG–Elektromagnetisk kompatibilitet – riktlinje 2004/108/EG
EG–Lågspänningsdirektiv 2006/95/EG
tillämpade harmoniserade normer, i synnerhet:
se föregående sida

NO
EU-Overensstemmelseserklæring
Vi erklærer hermed at denne enheten i utførelse som levert er i overensstemmelse med følgende relevante bestemmelser:
EG–EMV–Elektromagnetisk kompatibilitet 2004/108/EG
EG–Lavspenningsdirektiv 2006/95/EG
anvendte harmoniserte standarder, særlig:
se forrige side

FI
CE-standardinmukaissuusestote
Ilmoitamme täten, että tämä laite vastaa seuraavia asiaankuuluvia määräyksiä:
Sähkömagneettinen soveltuvuus 2004/108/EG
Matalajännite direktiivit: 2006/95/EG
käytetyt yhteensovitetut standardit, erityisesti:
katso edellinen sivu.

DA
EF-overensstemmelseserklæring
Vi erklærer hermed, at denne enhed ved levering overholder følgende relevante bestemmelser:
Elektromagnetisk kompatibilitet: 2004/108/EG
Lavvolts-direktiv 2006/95/EG
anvendte harmoniserede standarder, særligt:
se forrige side

HU
EK-megfelelőségi nyilatkozat
Ezennel kijelentjük, hogy az berendezés megfelel az alábbi irányelveknek:

Elektromágneses összeférhetőség irányelv: 2004/108/EK
Kisfeszültségű berendezések irányelv: 2006/95/EK
alkalmazott harmonizált szabványoknak, különösen:
lásd az előző oldalt

CS
Prohlášení o shodě ES
Prohlašujeme tímto, že tento agregát v dodaném provedení odpovídá následujícím příslušným ustanovením:

Směrnice o elektromagnetické kompatibilitě 2004/108/ES

Směrnice pro nízké napětí 2006/95/ES
použité harmonizační normy, zejména:
viz předchozí strana

PL
Deklaracja Zgodności WE
Niniejszym deklarujemy z pełną odpowiedzialnością, że dostarczony wyrób jest zgodny z następującymi dokumentami:

dyrektywą dot. kompatybilności elektromagnetycznej 2004/108/WE

dyrektywą niskonapięciową 2006/95/WE
stosowanymi normami zharmonizowanymi, a w szczególności:
patrz poprzednia strona

RU
Декларация о соответствии Европейским нормам
Настоящим документом заявляем, что данный агрегат в его объеме поставки соответствует следующим нормативным документам:

Электромагнитная устойчивость 2004/108/EG

Директивы по низковольтному напряжению 2006/95/EG
Используемые согласованные стандарты и нормы, в частности :
см. предыдущую страницу

EL
Δήλωση συμμόρφωσης της ΕΕ
Δηλώνουμε ότι το προϊόν αυτό ο' αυτή την κατάσταση παράδοσης ικανοποιεί τις ακόλουθες διατάξεις :
Ηλεκτρομαγνητική συμβατότητα ΕΚ-2004/108/ΕΚ
Οδηγία χαμηλής τάσης ΕΚ-2006/95/ΕΚ
Εναρμονισμένα χρησιμοποιούμενα πρότυπα, ιδιαίτερα:
Βλέπε προηγούμενη σελίδα

TR
CE Uygunluk Teyid Belgesi
Bu cihazın teslim edildiği şekliyle aşağıdaki standartlara uygun olduğunu teyid ederiz:
Elektromanyetik Uyumluluk 2004/108/EG
Alçak gerilim yönetmeliği 2006/95/EG
kısımın kullanılan standartlar için:
bkz. bir önceki sayfa

RO
EC-Declarație de conformitate
Prin prezenta declarăm că acest produs așa cum este livrat, corespunde cu următoarele prevederi aplicabile:
Compatibilitatea electromagnetică – directiva 2004/108/EG
Directiva privind tensiunea joasă 2006/95/EG
standarde armonizate aplicate, îndeosebi:
vezi pagina precedentă

ET
EÜ vastavusdeklaratsioon
Käesolevaga tõendame, et see toode vastab järgmistele asjakohastele
Elektromagnetilise ühilduvuse direktiiv 2004/108/EÜ
Madalpinge direktiiv 2006/95/EÜ
kohaldatud harmoneeritud standardid, eriti:
vt eelmist lk

LV
EC – atbilstības deklarācija
Ar šo mēs apliecinām, ka šis izstrādājums atbilst sekojošiem noteikumiem:
Elektromagnētiskās savietojamības direktīva 2004/108/EK
Zemsprieguma direktīva 2006/95/EK
piemēroti harmonizēti standarti, tai skaitā:
skatīt iepriekšējo lappusi

LT
EB atitikties deklaracija
Šiuo prezenta deklarām, kad šis gaminys atitinka šias normas ir direktyvas:
Elektromagnetinio suderinamumo direktyvą 2004/108/EB
Žemos įtampos direktyvą 2006/95/EB
pritaikytus vieningus standartus, o būtent:
žr. ankstesniai puslapyje

SK
ES vyhlášení o zhode
Týmto vyhlasujeme, že konštrukcie tejto konštrukčnej série v dodanom vyhotovení vyhovujú nasledujúcim príslušným ustanoveniam:

Elektromagnetická zhoda – smernica 2004/108/ES
Nízkonapäťové zariadenia – smernica 2006/95/ES
používané harmonizované normy, najmä:
pozri predchádzajúcu stranu

SL
ES – izjava o skladnosti
Izjavljamo, da dobavljene vrste izvedbe te serije ustrezajo sledečim zadevnim določilom:

Direktiva o elektromagnetni združljivosti 2004/108/ES
Direktiva o niski napetosti 2006/95/ES
uporabljeni harmonizirani standardi, predvsem:
glejte prejšnjo stran

BG
EO-Декларация за съответствие
Декларираме, че продуктът отговаря на следните изисквания:

Електромагнитна съвместимост – директива 2004/108/EO
Директива ниско напрежение 2006/95/EO
Хармонизирани стандарти:
вж. предната страница

MT
Dikjarazzjoni ta' konformità KE
B'dan il-meż, niddikjaraw li l-prodotti tas-serje jissodisfaw id-dispożizzjonijiet rilevanti li ġejjin:
Kompatibbiltà elettromanjetika – Direttiva 2004/108/KE
Vultaġġ baxx – Direttiva 2006/95/KE
b'mod partikolari:
ara l-paġna ta' qabel

HR
EZ izjava o sukladnosti
Ovim izjavljujemo da vrste konstrukcije serije u isporučenoj izvedbi odgovaraju sljedećim važećim propisima:
Elektromagnetna kompatibilnost – smjernica 2004/108/EZ
Smjernica o niskom naponu 2006/95/EZ
primijenjene harmonizirane norme, posebno:
vidjeti prethodnu stranicu

SR
EZ izjava o usklađenosti
Ovim izjavljujemo da vrste konstrukcije serije u isporučenoj verziji odgovaraju sledećim važećim propisima:
Elektromagnetna kompatibilnost – direktiva 2004/108/EZ
Direktivi za niski napon 2006/95/EZ
primenjeni harmonizovani standardi, a posebno:
vidi prethodnu stranu

wilo

WILO SE
Nortkirchenstraße 100
44263 Dortmund
Germany

Wilo – International (Subsidiaries)

Argentina WILO SALMSON Argentina S.A. C1295ABI Ciudad Autónoma de Buenos Aires T +54 11 4361 5929 carlos.musich@wilo.com.ar	Cuba WILO SE Oficina Comercial Edificio Simona Apto 105 Siboney. La Habana. Cuba T +53 5 2795135 T +53 7 272 2330 raul.rodriguez@wilo-cuba.com	Ireland WILO Ireland Limerick T +353 61 227566 sales@wilo.ie	Romania WILO Romania s.r.l. 077040 Com. Chiajna Jud. Ilfov T +40 21 3170164 wilo@wilo.ro	Ukraine WILO Ukraina t.o.w. 08130 Kiev T +38 044 3937384 wilo@wilo.ua
Australia WILO Australia Pty Limited Murrarrie, Queensland, 4172 T +61 7 3907 6900 chris.dayton@wilo.com.au	Czech Republic WILO CS, s.r.o. 25101 Cestlice T +420 234 098711 info@wilo.cz	Italy WILO Italia s.r.l. Via Novegro, 1/A20090 Segrate MI T +39 25538351 wilo.italia@wilo.it	Russia WILO Rus ooo 123592Moscow T +7 495 7810690 wilo@wilo.ru	United Arab Emirates WILO Middle East FZE Jebel Ali Free zone – South PO Box 262720 Dubai T +971 4 880 91 77 info@wilo.ae
Austria WILO Pumpen Österreich GmbH 2351 Wiener Neudorf T +43 507 507-0 office@wilo.at	Denmark WILO Danmark A/S 2690 Karlslunde T +45 70 253312 wilo@wilo.dk	Kazakhstan WILO Central Asia 050002 Almaty T +7 727 312 40 10 info@wilo.kz	Saudi Arabia WILO Middle East KSA Riyadh 11465 T +966 1 4624430 wshoula@wataniaind.com	USA WILO USA LLC Rosemont, IL 60018 T +1 866 945 6872 info@wilo-usa.com
Azerbaijan WILO Caspian LLC 1065 Baku T +994 12 5962372 info@wilo.az	Estonia WILO Eesti OÜ 12618 Tallinn T +372 6 509780 info@wilo.ee	Korea WILO Pumps Ltd. 20 Gangseo, Busan T +82 51 950 8000 wilo@wilo.co.kr	Serbia and Montenegro WILO Beograd d.o.o. 11000 Beograd T +381 11 2851278 office@wilo.rs	Vietnam WILO Vietnam Co Ltd. Ho Chi Minh City, Vietnam T +84 8 38109975 nkminh@wilo.vn
Belarus WILO Bel IOOO 220035 Minsk T +375 17 3963446 wilo@wilo.by	Finland WILO Finland OY 02330 Espoo T +358 207401540 wilo@wilo.fi	Latvia WILO Baltic SIA 1019 Riga T +371 6714-5229 info@wilo.lv	Slovakia WILO CS s.r.o., org. Zložka 83106 Bratislava T +421 2 33014511 info@wilo.sk	
Belgium WILO NV/SA 1083 Ganshoren T +32 2 4823333 info@wilo.be	France Wilo Salmson France S.A.S. 53005 Laval Cedex T +33 2435 95400 info@wilo.fr	Lebanon WILO LEBANON SARL Jdeideh 1202 2030 Lebanon T +961 1 888910 info@wilo.com.lb	Slovenia WILO Adriatic d.o.o. 1000 Ljubljana T +386 1 5838130 wilo.adriatic@wilo.si	
Bulgaria WILO Bulgaria EOOD 1125 Sofia T +359 2 9701970 info@wilo.bg	Great Britain WILO (U.K.) Ltd. Burton Upon Trent DE14 2WJ T +44 1283 523000 sales@wilo.co.uk	Lithuania WILO Lietuva UAB 03202 Vilnius T +370 5 2136495 mail@wilo.lt	South Africa Wilo Pumps SA Pty LTD 1685 Midrand T +27 11 6082780 patrick.hulley@salmson.co.za	
Brazil WILO Comercio e Importacao Ltda Jundiaí – São Paulo – Brasil 13.213-105 T +55 11 2923 9456 wilo@wilo-brasil.com.br	Greece WILO Hellas SA 4569 Anixi (Attika) T +302 10 6248300 wilo.info@wilo.gr	Morocco WILO Maroc SARL 20250 Casablanca T +212 (0) 5 22 66 09 24 contact@wilo.ma	Spain WILO Ibérica S.A. 8806 Alcalá de Henares (Madrid) T +34 91 8797100 wilo.iberica@wilo.es	
Canada WILO Canada Inc. Calgary, Alberta T2A 5L7 T +1 403 2769456 info@wilo-canada.com	Hungary WILO Magyarország Kft 2045 Törökbálint (Budapest) T +36 23 889500 wilo@wilo.hu	The Netherlands WILO Nederland B.V. 1551 NA Westzaan T +31 88 9456 000 info@wilo.nl	Sweden WILO NORDIC AB 35033 Växjö T +46 470 727600 wilo@wilo.se	
China WILO China Ltd. 101300 Beijing T +86 10 58041888 wilobj@wilo.com.cn	India Wilo Mather and Platt Pumps Private Limited Pune 411019 T +91 20 27442100 services@matherplatt.com	Norway WILO Norge AS 0975 Oslo T +47 22 804570 wilo@wilo.no	Switzerland Wilo Schweiz AG 4310 Rheinfelden T +41 61 836 80 20 info@wilo.ch	
Croatia WILO Hrvatska d.o.o. 10430 Samobor T +38 51 3430914 wilo-hrvatska@wilo.hr	Indonesia PT. WILO Pumps Indonesia Jakarta Timur, 13950 T +62 21 7247676 citrawilo@cbn.net.id	Poland WILO Polska Sp. z.o.o. 5-506 Lesznowola T +48 22 7026161 wilo@wilo.pl	Taiwan WILO Taiwan CO., Ltd. 24159 New Taipei City T +886 2 2999 8676 nelson.wu@wilo.com.tw	
		Portugal Bombas Wilo-Salmson Sistemas Hidraulicos Lda. 4475-330 Maia T +351 22 2080350 bombas@wilo.pt	Turkey WILO Pompa Sistemleri San. ve Tic. A.Ş. 34956 İstanbul T +90 216 2509400 wilo@wilo.com.tr	

wilo

Pioneering for You

WILO SE
Nortkirchenstraße 100
D-44263 Dortmund
Germany
T +49(0)231 4102-0
F +49(0)231 4102-7363
wilo@wilo.com
www.wilo.com