

**Data Sheet | Item Number: 2734-1107/328-000**

1-conductor female connector; lever; Push-in CAGE CLAMP®; 1.5 mm<sup>2</sup>; Pin spacing 3.5 mm; 7-pole; 100% protected against mismatching; Centered locking levers; 1,50 mm<sup>2</sup>; light gray



<https://www.wago.com/2734-1107/328-000>



Color: ■ light gray

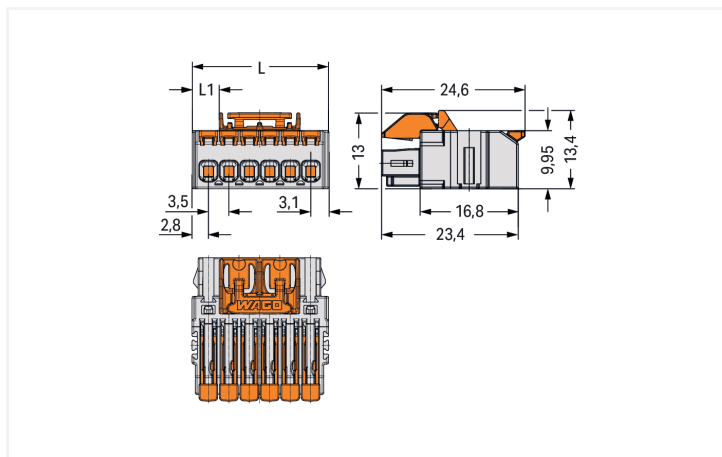

**Dimensions in mm**

$L = (\text{pole no.} \times \text{pin spacing}) + 2.4 \text{ mm}$  Pole no. 4:  $L1 = 1.15 \text{ mm}$  Pole no. 5 + 6:  $L1 = 4.65 \text{ mm}$  Pole no. 7 + 8:  $L1 = 8.15 \text{ mm}$  Pole no. 9 + 10:  $L1 = 11.65 \text{ mm}$  Pole no. 11 + 12:  $L1 = 15.15 \text{ mm}$  Pole no. 13 + 14:  $L1 = 18.65 \text{ mm}$  Pole no. 15 + 16:  $L1 = 22.15 \text{ mm}$

Female connector, 2734 Series, 0° conductor exit to connection direction

Our female connector (item number 2734-1107/328-000) simplifies electrical installations. Conductors should only be connected to this female connector if their strip length is between 9 and 10 mm. This product incorporates one conductor terminal and utilizes Push-in CAGE CLAMP®. Push-in CAGE CLAMP® technology provides a universal connection solution for any type of conductor. It allows both solid and fine-stranded conductors with ferrules to be inserted directly into the clamping point without the need for tools. The dimensions are (26.9 x 13.4 x 24.6) mm (width x height x depth). This female connector is suitable for conductor cross sections ranging from 0.14 mm² to 1.5 mm².

Tin is used for coating the contact surfaces.

| Notes              |   |
|--------------------|---|
| Safety Information | The MCS – MULTI CONNECTION SYSTEM includes connectors without breaking capacity in accordance with DIN EN 61984. When used as intended, these connectors must not be connected/disconnected when live or under load. When used as intended, these connectors must not be connected/disconnected when live or under load. The circuit design should ensure header pins, which can be touched, are not live when unmated. |
| Variants:          | Other pole numbers<br>Other versions (or variants) can be requested from WAGO Sales or configured at <a href="https://configurator.wago.com/">https://configurator.wago.com/</a> .  |

| Electrical data                 |                |        |        |               |         |   |       |
|---------------------------------|----------------|--------|--------|---------------|---------|---|-------|
| Ratings per                     | IEC/EN 60664-1 |        |        | Approvals per | UL 1059 |   |       |
| Overvoltage category            | III            | III    | II     | Use group     | B       | C | D     |
| Pollution degree                | 3              | 2      | 2      | Rated voltage | 300 V   | - | 300 V |
| Nominal voltage                 | 160 V          | 160 V  | 320 V  | Rated current | 10 A    | - | 10 A  |
| Rated impulse withstand voltage | 2.5 kV         | 2.5 kV | 2.5 kV |               |         |   |       |
| Rated current                   | 10 A           | 10 A   | 10 A   |               |         |   |       |

| Approvals per | CSA   |   |       |
|---------------|-------|---|-------|
| Use group     | B     | C | D     |
| Rated voltage | 300 V | - | 300 V |
| Rated current | 10 A  | - | 10 A  |

| Connection Data            |   | Connection 1                                      |                                    |
|----------------------------|---|---|------------------------------------|
| Clamping units             | 7 | Connection technology                             | Push-in CAGE CLAMP®                |
| Total number of potentials | 7 | Actuation type                                    | Lever                              |
| Number of connection types | 1 | Solid conductor                                   | 0.14 ... 1.5 mm² / 26 ... 14 AWG   |
| Number of levels           | 1 | Solid conductor; push-in termination              | 0.34 ... 1.5 mm² / 22 ... 14 AWG   |
|                            |   | Fine-stranded conductor                           | 0.14 ... 1.5 mm² / 26 ... 14 AWG   |
|                            |   | Fine-stranded conductor; with insulated ferrule   | 0.14 ... 0.75 mm²                  |
|                            |   | Fine-stranded conductor; with uninsulated ferrule | 0.14 ... 1 mm²                     |
|                            |   | Strip length                                      | 9 ... 10 mm / 0.35 ... 0.39 inches |
|                            |   | Pole number                                       | 7                                  |
|                            |   | Conductor entry direction to mating direction     | 0°                                 |

### Physical data

|             |                        |
|-------------|------------------------|
| Pin spacing | 3.5 mm / 0.138 inches  |
| Width       | 26.9 mm / 1.059 inches |
| Height      | 13.4 mm / 0.528 inches |
| Depth       | 24.6 mm / 0.969 inches |

### Mechanical data

|                          |     |
|--------------------------|-----|
| Variable coding          | Yes |
| Anti-rotation protection | Yes |

### Plug-in connection

|                                    |                         |
|------------------------------------|-------------------------|
| Contact type (pluggable connector) | Female connector/socket |
| Connector (connection type)        | for conductor           |
| Mismating protection               | Yes                     |
| Locking of plug-in connection      | Center locking lever    |

### Material data

|                                    |  |
|------------------------------------|--|
| Note (material data)               | <a href="#">Information on material specifications can be found here</a> |
| Color                              | light gray   |
| Material group                     | I  |
| Insulation material (main housing) | Polyamide (PA66)   |
| Flammability class per UL94        | V0   |
| Clamping spring material           | Chrome-nickel spring steel (CrNi)  |
| Contact material                   | Copper alloy   |
| Contact Plating                    | Tin  |
| Fire load                          | 0.106 MJ   |
| Weight                             | 6 g  |

### Environmental requirements

|                         |                 |
|-------------------------|-----------------|
| Limit temperature range | -60 ... +100 °C |
| Processing temperature  | -35 ... +60 °C  |

### Commercial data

|                       |               |
|-----------------------|---------------|
| PU (SPU)              | 50 pcs        |
| Packaging type        | Box           |
| Country of origin     | DE            |
| GTIN                  | 4066966264203 |
| Customs tariff number | 85366990990   |

### Product Classification

|           |                      |
|-----------|----------------------|
| UNSPSC    | 39121409             |
| ETIM 9.0  | EC002638             |
| ETIM 10.0 | EC002638             |
| ECCN      | NO US CLASSIFICATION |

| Environmental Product Compliance |                         |
|----------------------------------|-------------------------|
| RoHS Compliance Status           | Compliant, No Exemption |

### Approvals / Certificates

#### General approvals



| Approval                             | Standard      | Certificate Name |
|--------------------------------------|---------------|------------------|
| CSA<br>DEKRA Certification B.V.      | C22.2 No. 158 | 2314554          |
| UL<br>Underwriters Laboratories Inc. | UL 1059       | E45172           |
| UL<br>Underwriters Laboratories Inc. | UL 1977       | E 45171          |

### Downloads

#### Environmental Product Compliance

| Compliance Search                                     |                   |
|---|-------------------|
| Environmental Product Compliance<br>2734-1107/328-000 | <a href="#">↓</a> |

### Documentation

| Additional Information |            |                   |                   |
|------------------------|------------|-------------------|-------------------|
| Technical Section      | 03.04.2019 | pdf<br>2027.26 KB | <a href="#">↓</a> |

### CAD/CAE-Data

| CAD data                          |                   |
|-----------------------------------|-------------------|
| 2D/3D Models<br>2734-1107/328-000 | <a href="#">↓</a> |

| PCB Design   |                   |
|--|-------------------|
| Symbol and Footprint<br>via SamacSys<br>2734-1107/328-000        | <a href="#">↓</a> |
| Symbol and Footprint<br>via Ultra Librarian<br>2734-1107/328-000 | <a href="#">↓</a> |

## 1 Compatible Products

### 1.1 System counterpart

#### 1.1.1 Male connector/plug



**Item No.: 734-307**

1-conductor male connector; CAGE CLAMP®; 1.5 mm<sup>2</sup>; Pin spacing 3.5 mm; 7-pole; 100% protected against mismatching; 1,50 mm<sup>2</sup>; light gray

**Item No.: 734-167**

THT male header; 1.0 x 1.0 mm solder pin; angled; 100% protected against mismatching; Pin spacing 3.5 mm; 7-pole; light gray

**Item No.: 734-137**

THT male header; 1.0 x 1.0 mm solder pin; straight; 100% protected against mismatching; Pin spacing 3.5 mm; 7-pole; light gray

## 1.2 Optional Accessories

### 1.2.1 Coding

#### 1.2.1.1 Coding



**Item No.: 2734-505**

Coding pin carrier; 5 coding keys; for female connectors; orange

### 1.2.2 Ferrule

#### 1.2.2.1 Ferrule



**Item No.: 216-241**

Ferrule; Sleeve for 0.5 mm<sup>2</sup> / 20 AWG; insulated; electro-tin plated; electrolytic copper; gastight crimped; acc. to DIN 46228, Part 4/09.90; white

**Item No.: 216-141**

Ferrule; Sleeve for 0.5 mm<sup>2</sup> / 20 AWG; un-insulated; electro-tin plated; electrolytic copper; gastight crimped; acc. to DIN 46228, Part 1/08.92

**Item No.: 216-242**

Ferrule; Sleeve for 0.75 mm<sup>2</sup> / 18 AWG; insulated; electro-tin plated; electrolytic copper; gastight crimped; acc. to DIN 46228, Part 4/09.90; gray

**Item No.: 216-262**

Ferrule; Sleeve for 0.75 mm<sup>2</sup> / 18 AWG; insulated; electro-tin plated; electrolytic copper; gastight crimped; acc. to DIN 46228, Part 4/09.90; gray



**Item No.: 216-142**

Ferrule; Sleeve for 0.75 mm<sup>2</sup> / 18 AWG; un-insulated; electro-tin plated; electrolytic copper; gastight crimped; acc. to DIN 46228, Part 1/08.92

### 1.2.3 Jumper

#### 1.2.3.1 Jumper



**Item No.: 2734-402**

Jumper; for conductor entry; 2-way; insulated; light gray

## 1.2.4 Strain relief

### 1.2.4.1 Strain relief plate



**Item No.: 2734-534**

Strain relief plate; for female connectors; 13 mm wide; 1 part; lever; Pin spacing 3.5 mm; light gray

## 1.2.5 Test and measurement

### 1.2.5.1 Testing accessories



**Item No.: 735-500**

WAGO Test pin; 1 mm Ø; 30 V AC / 60 V DC; CAT0; 1 A; 6 mm uninsulated; Test lead for soldering up to 0,5mm<sup>2</sup>

## Installation Notes

### Conductor termination

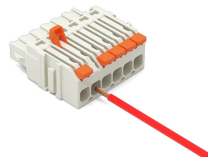
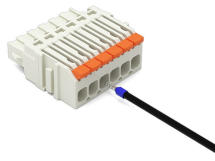
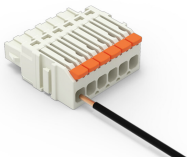

### Conductor removal

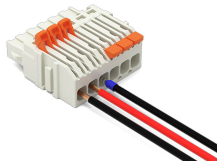

## Testing

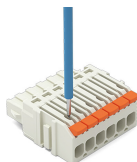
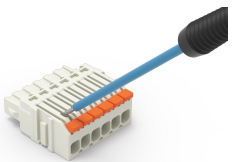

Marking

