

User- and installer manual

METROAIR L

Air-water heat pump

Table of Contents

1	<i>Important information</i>	4	7	<i>Control - Heat pump EB101</i>	32
	System solution	4			
	Safety information	4	8	<i>Disturbances in comfort</i>	33
	Symbols	4			
	Marking	4	9	<i>Alarm list</i>	34
	Safety precautions	4	10	<i>Technical data</i>	38
	Serial number	6		Dimensions	38
	Recovery	6		Sound pressure levels	42
	Environmental information	6		Technical specifications	43
	Checklist: Checks before commissioning	7		Working area	46
2	<i>Delivery and handling</i>	9		Capacity and COP	46
	Transport and storage	9		Output with lower fuse rating than recommended	49
	Assembly	9		Energy labelling	50
	Removing the covers	13		Electrical circuit diagram	55
3	<i>The heat pump design</i>	15		<i>Item register</i>	59
	Component locations METROAIR L6	15			
	Component locations METROAIR L8	16			
	Component locations METROAIR L12	17			
	List of components METROAIR L	18			
	Electrical panel	20			
	Sensor placement	22			
4	<i>Pipe connections</i>	25			
5	<i>Electrical connections</i>	26			
	General	26			
	Electrical components	27			
	Accessibility, electrical connection	27			
	Connections	28			
6	<i>Commissioning and adjusting</i>	31			
	Compressor heater	31			

1 Important information

System solution

METROAIR L is intended for installation with indoor module (SHK or Hydrobox) for a complete system solution.

Safety information

This manual describes installation and service procedures for implementation by specialists.

The manual must be left with the customer.

This appliance can be used by children aged from 8 years and above and persons with reduced physical, sensory or mental capabilities or lack of experience and knowledge if they have been given supervision or instruction concerning use of the appliance in a safe way and understand the hazards involved. The product is intended for use by experts or trained users in shops, hotels, light industry, farming and similar environments.

Children must be instructed/supervised to ensure that they do not play with the appliance.

Do not allow children to clean or maintain the appliance unsupervised.

Rights to make any design or technical modifications are reserved.

Symbols



NOTE

This symbol indicates danger to person or machine .



Caution

This symbol indicates important information about what you should consider when installing or servicing the installation.



TIP

This symbol indicates tips on how to facilitate using the product.

Marking

CE The CE mark is obligatory for most products sold in the EU, regardless of where they are made.

IP21 Classification of enclosure of electro-technical equipment.



Danger to person or machine.



Read the User Manual.

Safety precautions

CAUTION

Install the system in full accordance with this installation manual. Incorrect installation can cause bursts, personal injury, water leaks, refrigerant leaks, electric shocks and fire.

Pay attention to the measurement values before working on the cooling system, especially when servicing in small rooms, so that the limit for the refrigerant's concentration is not exceeded.

Consult an expert to interpret the measurement values. If the refrigerant concentration exceeds the limit, there may be a shortage of oxygen in the event of any leak, which can cause serious injury.

Use original accessories and the stated components for the installation.

If parts other than those stated by us are used, water leaks, electric shocks, fire and personal injury may occur as the unit may not work properly.

Ventilate the working area well – refrigerant leakage may occur during service work.

If the refrigerant comes into contact with naked flames, poisonous gas is created.

Install the unit in a location with good support.

Unsuitable installation locations can cause the unit to fall and cause material damage and personal injury. Installation without sufficient support can also cause vibrations and noise.

Ensure that the unit is stable when installed, so that it can withstand earthquakes and strong winds.

Unsuitable installation locations can cause the unit to fall and cause material damage and personal injury.

The electrical installation must be carried out by a qualified electrician and the system must be connected as a separate circuit.

Power supply with insufficient capacity and incorrect function can cause electric shocks and fire.

Use the stated cables for the electrical connection, tighten the cables securely in the terminal blocks and relieve the wiring correctly to prevent overloading the terminal blocks.

Loose connections or cable mountings can cause abnormal heat production or fire.

Check, after completed installation or service, that no refrigerant leaks from the system in gas form.

If refrigerant gas leaks into the house and comes into contact with an aerotemp, an oven or other hot surface, poisonous gases are produced.

Switch off the compressor before opening/breaching the refrigerant circuit.

If the refrigerant circuit is breached /opened whilst the compressor is running, air can enter the process circuit. This can cause unusually high pressure in the process circuit, which can cause bursts and personal injury.

Switch off the power supply in the event of a service or inspection.

If the power supply is not shut off, there is a risk of electric shocks and damage due to the rotating fan.

Do not run the unit with removed panels or protection.

Touching rotating equipment, hot surfaces or high voltage parts can cause personal injury due to entrapment, burns or electric shocks.

Cut the power before starting electrical work.

Failure to cut the power can cause electric shocks, damage and incorrect function of the equipment.

CARE

Carry out the electrical installation with care.

Do not connect the ground lead to the gas line, water line, lightning conductor or telephone line's ground lead. Incorrect grounding can cause unit faults such as electric shocks due to short-circuiting.

Use main switch with sufficient breaking capacity.

If the switch does not have sufficient breaking capacity, malfunctions and fire can occur.

Always use a fuse with the correct rating in the locations where fuses are to be used.

Connecting the unit with copper wire or other metal thread can cause unit breakdown and fire.

Cables must be routed so that they are not damaged by metal edges or trapped by panels.

Incorrect installation can cause electric shocks, heat generation and fire.

Do not install the unit in close proximity to locations where leakage of combustible gases can occur.

If leaking gases collect around the unit, fire may occur.

Do not install the unit where corrosive gas (for example nitrous fumes) or combustible gas or steam (for example thinner and petroleum gases) can build up or collect, or where volatile combustible substances are handled.

Corrosive gas can cause corrosion to the heat exchanger, breaks in plastic parts etc. and combustible gas or steam can cause fire.

Do not use the unit where water splashes may occur, for example in laundries.

The indoor section is not waterproof and electric shocks and fire can therefore occur.

Do not use the unit for specialist purposes such as for storing food, cooling precision instruments, freeze-conservation of animals, plants or art.

This can damage the items.

Do not install and use the system close to equipment that generates electromagnetic fields or high frequency harmonics.

Equipment such as inverters, standby sets, medical high frequency equipment and telecommunications equipment can affect the unit and cause malfunctions and breakdowns. The unit can also affect medical equipment and telecommunications equipment, so that it functions incorrectly or not at all.

Do not install the outdoor unit in the locations stated below.

- Locations where leakage of combustible gas can occur.
- Locations where carbon fibre, metal powder or other powder that can enter the air.
- Locations where substances that can affect the unit, for example, sulphide gas, chlorine, acid or alkaline substances can occur.
- Locations with direct exposure to oil mist or steam.
- Vehicles and ships.
- Locations where machines that generate high frequency harmonics are used.
- Locations where cosmetic or special sprays are often used.
- Locations that can be subjected to direct salty atmospheres. In this case, the outdoor unit must be protected against direct intakes of salty air.
- Locations where large amounts of snow occur.
- Locations where the system is exposed to chimney smoke.

If the bottom frame of the outdoor section is corroded, or in any other way damaged, due to long periods of operation, it must not be used.

Using an old and damaged frame can cause the unit to fall and cause personal injury.

If soldering near the unit, ensure that solder residue does not damage the drip tray.

If solder residue enters the unit during soldering, small holes can appear in the tray resulting in water leakage. To prevent damage, keep the indoor unit in its packing or cover it.

Do not allow the drainage pipe to exit into channels where poisonous gases, containing sulphides for example, can occur.

If the pipe exits into such a channel, any poisonous gases will flow into the room and seriously affect the user's health and safety.

Insulate the unit's connection pipes so that the ambient air moisture does not condense on them.

Insufficient insulation can cause condensation, which can lead to moisture damage on the roof, floor, furniture and valuable personal property.

Do not install the outdoor unit in a location where insects and small animals can inhabit.

Insects and small animals can enter the electronic parts and cause damage and fire. Instruct the user to keep the surrounding equipment clean.

Take care when carrying the unit by hand.

If the unit weighs more than 20 kg, it must be carried by two people. Wear safety gloves to minimise the risk of cuts.

Dispose of any packaging material correctly.

Any remaining packaging material can cause personal injury as it may contain nails and wood.

Do not touch any buttons with wet hands.

This can cause electric shocks.

Do not touch any refrigerant pipes with your hands when the system is in operation.

During operation the pipes become extremely hot or extremely cold, depending on the method of operation. This can cause burn injuries or frost injuries.

Do not shut off the power supply immediately after operation has started.

Wait at least 5 minutes, otherwise there is a risk of water leakage or breakdown.

Do not control the system with the main switch.

This can cause fire or water leakage. In addition, the fan can start unexpectedly, which can cause personal injury.

Serial number

You can find the service code and the serial number (PF3) on the right-hand side of METROAIR L.

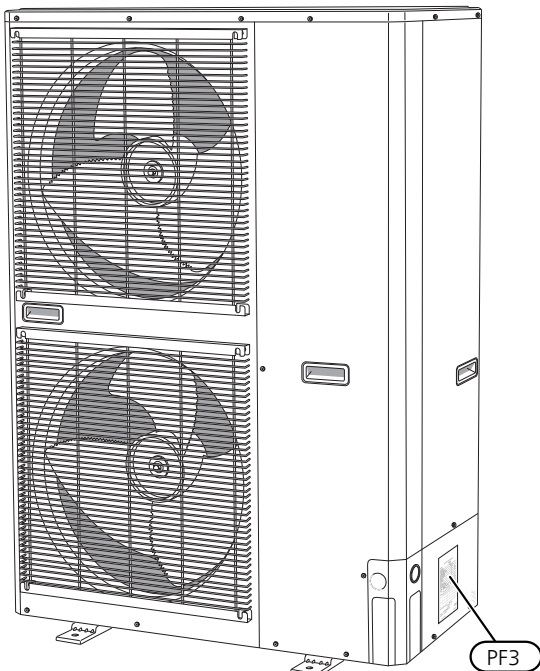
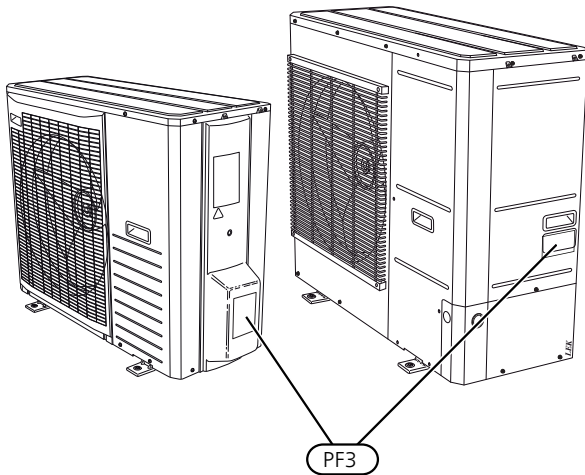
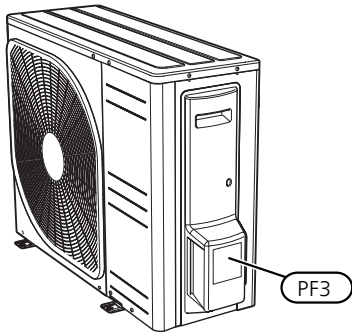

Caution

You need the product's service code and serial number for servicing and support.

Recovery



Leave the disposal of the packaging to the installer who installed the product or to special waste stations.

Do not dispose of used products with normal household waste. It must be disposed of at a special waste station or dealer who provides this type of service.

Improper disposal of the product by the user results in administrative penalties in accordance with current legislation.

Environmental information

This unit contains a fluorinated greenhouse gas that is covered by the Kyoto agreement.

The equipment contains R410A, a fluorinated greenhouse gas with a GWP value (Global Warming Potential) of 2088. Do not release R410A into the atmosphere.

Checklist: Checks before commissioning

<i>Refrigerant system</i>	<i>Notes</i>	<i>Checked</i>
Pipe length		<input type="checkbox"/>
Height difference		<input type="checkbox"/>
Pressurization test		<input type="checkbox"/>
Leak testing		<input type="checkbox"/>
End pressure vacuum		<input type="checkbox"/>
Pipe insulation		<input type="checkbox"/>

<i>Electrical installation</i>	<i>Notes</i>	<i>Checked</i>
Property's main fuse		<input type="checkbox"/>
Group fuse		<input type="checkbox"/>
Load monitor / current sensor (Connects to indoor module / control module.)		<input type="checkbox"/>
KVR 10		<input type="checkbox"/>
When installing METROAIR L6 / SHK 200S-6 / Hydrobox 6kW, check that the software version of the indoor module is at least v8320.		<input type="checkbox"/>

<i>Cooling</i>	<i>Notes</i>	<i>Checked</i>
Pipe system, condensation insulation		<input type="checkbox"/>
		<input type="checkbox"/>

2 Delivery and handling

Transport and storage

METROAIR L must be transported and stored vertically.



NOTE

Ensure that the heat pump cannot fall over during transport.

Assembly

- Place METROAIR L outdoors on a solid level base that can take the weight, preferably a concrete foundation. If concrete slabs are used they must rest on asphalt or shingle.
- The concrete foundation or slabs must be positioned so that the lower edge of the evaporator is at the level of the average local snow depth; however, a minimum of 300mm. See our stands and brackets on page 37.
- METROAIR L should not be positioned next to noise sensitive walls, for example, next to a bedroom.
- Also ensure that the placement does not inconvenience the neighbours.
- METROAIR L must not be placed so that recirculation of the outdoor air can occur. This causes lower output and impaired efficiency.
- The evaporator should be sheltered from direct wind, which negatively affects the defrosting function. Place METROAIR L protected from wind against the evaporator.
- Large amounts of condensation water, as well as melt water from defrosting, can be produced. Condensation water must be led off to a drain or similar (see page 10).
- Care must be exercised so that the heat pump is not scratched during installation.

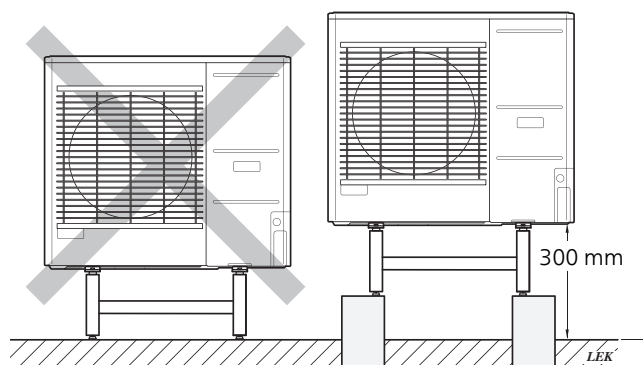

Do not place METROAIR L directly on the lawn or other non-solid surface.

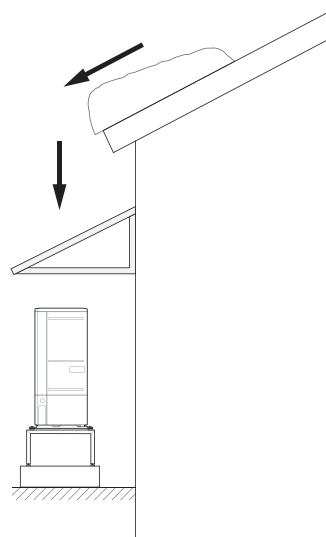

If there is a risk of snow slip from roof, a protective roof or cover must be erected to protect the heat pump, pipes and wiring.

LIFT FROM THE STREET TO THE SET UP LOCATION

If the base allows, the simplest thing is to use a pallet truck to move the METROAIR L to the set up location.



NOTE

The centre of gravity is offset to one side (see print on the packaging).

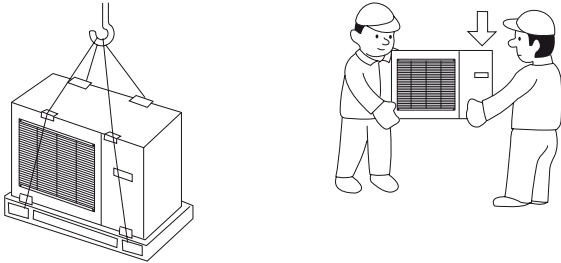

If METROAIR L needs to be transported across soft ground, such as a lawn, we recommend that a crane truck is used that can lift the unit to the installation location. When METROAIR L is lifted with a crane, the packaging must be undamaged and the load distributed with a boom, see the illustration above.

If a crane cannot be used METROAIR L can be transported using an extended sack truck. METROAIR L must be used on the side marked "heavy side" and two people are required to get the METROAIR L up.

LIFT FROM THE PALLET TO FINAL POSITIONING

Before lifting remove the packaging and the securing strap to the pallet.

Place lifting straps around each machine foot. Lifting from the pallet to the base requires four persons, one for each lifting strap.

It is not permitted to lift anything other than the machine feet.

SCRAPPING

When scrapping, the product is removed in reverse order. Lift by the bottom panel instead of a pallet!

CONDENSATION RUN OFF

Condensation runs out on to the ground below METROAIR L. To avoid damage to the house and heat pump, the condensation must be gathered and drained away.



NOTE

It is important to the heat pump function that condensation water is led away and that the drain for the condensation water run off is not positioned so that it can cause damage to the house.



NOTE

To ensure this function, the accessory KVR 10 should be used. (Not included)



NOTE

The electrical installation and wiring must be carried out under the supervision of an authorised electrician.



NOTE

Self regulating heating cables must not be connected.

- The condensation water (up to 50 litres / 24 hrs) must be routed away by a pipe to an appropriate drain, it is recommended that the shortest outdoor length possible is used.
- The section of the pipe that can be affected by frost must be heated by the heating cable to prevent freezing.
- Route the pipe downward from METROAIR L.
- The outlet of the condensation water pipe must be at a depth that is frost free or alternatively indoors (with reservation for local ordinances and regulations).
- Use a water trap for installations where air circulation may occur in the condensation water pipe.
- The insulation must be tight against the bottom of the condensation water trough.

Drain pan heater, control

The drain pan heater is supplied with power when one of the following conditions is met:

1. The compressor has been in operation for at least 30 minutes after last start.
2. The ambient temperature is lower than 1 °C.

Recommended alternative for leading off condensation water

Drain indoors

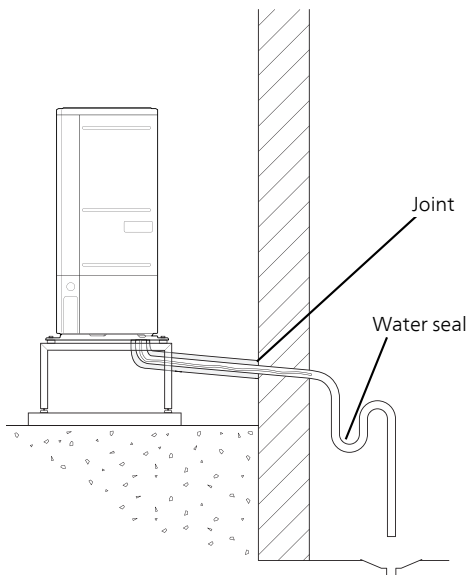

The condensation water is lead to an indoor drain (subject to local rules and regulations).

Route the pipe downward from the air/water heat pump.

The condensation water pipe must have a water seal to prevent air circulation in the pipe.

KVR 10 spliced as illustrated. Pipe routing inside house not included.

Stone caisson

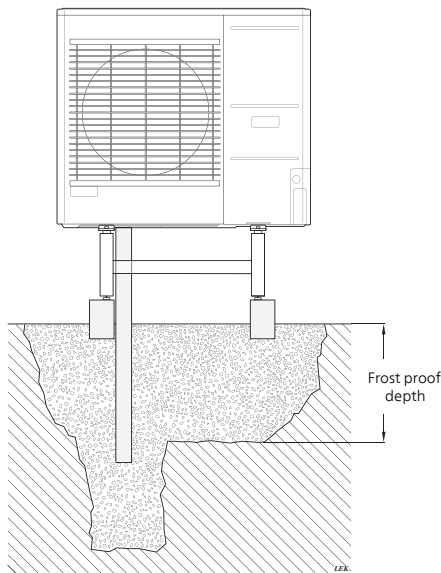

If the house has a cellar the stone caisson must be positioned so that condensation water does not affect the house. Otherwise the stone caisson can be positioned directly under the heat pump.

The outlet of the condensation water pipe must be at frost free depth.

Gutter drainage



NOTE

Bend the hose to create a water seal, see illustration.

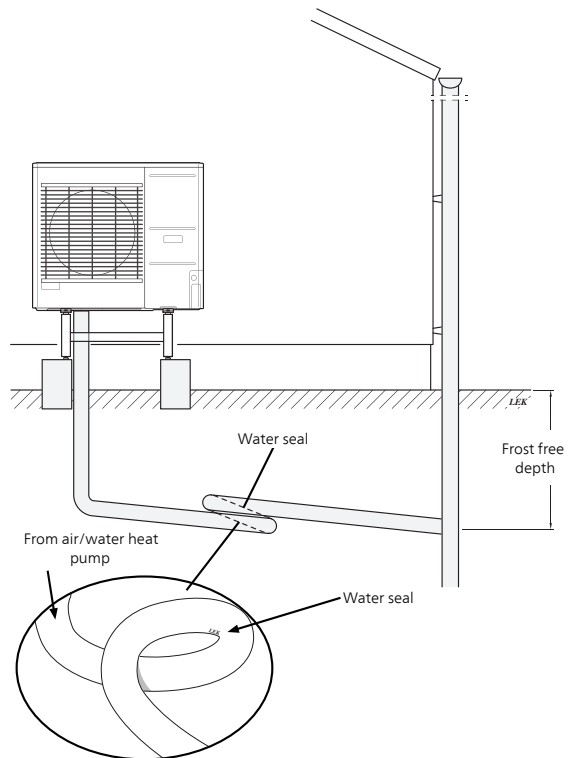

- The outlet of the condensation water pipe must be at frost free depth.
- Route the pipe downward from the air/water heat pump.
- The condensation water pipe must have a water seal to prevent air circulation in the pipe.
- The installation length can be adjusted by the size of the water seal.



Caution

If none of the recommended alternatives is used good lead off of condensation water must be assured.

INSTALLATION AREA

The recommended distance between METROAIR L and the house wall must be at least 15 cm. Clearance above METROAIR L should be at least 100 cm. However, free space in front must be 100 cm for future servicing.

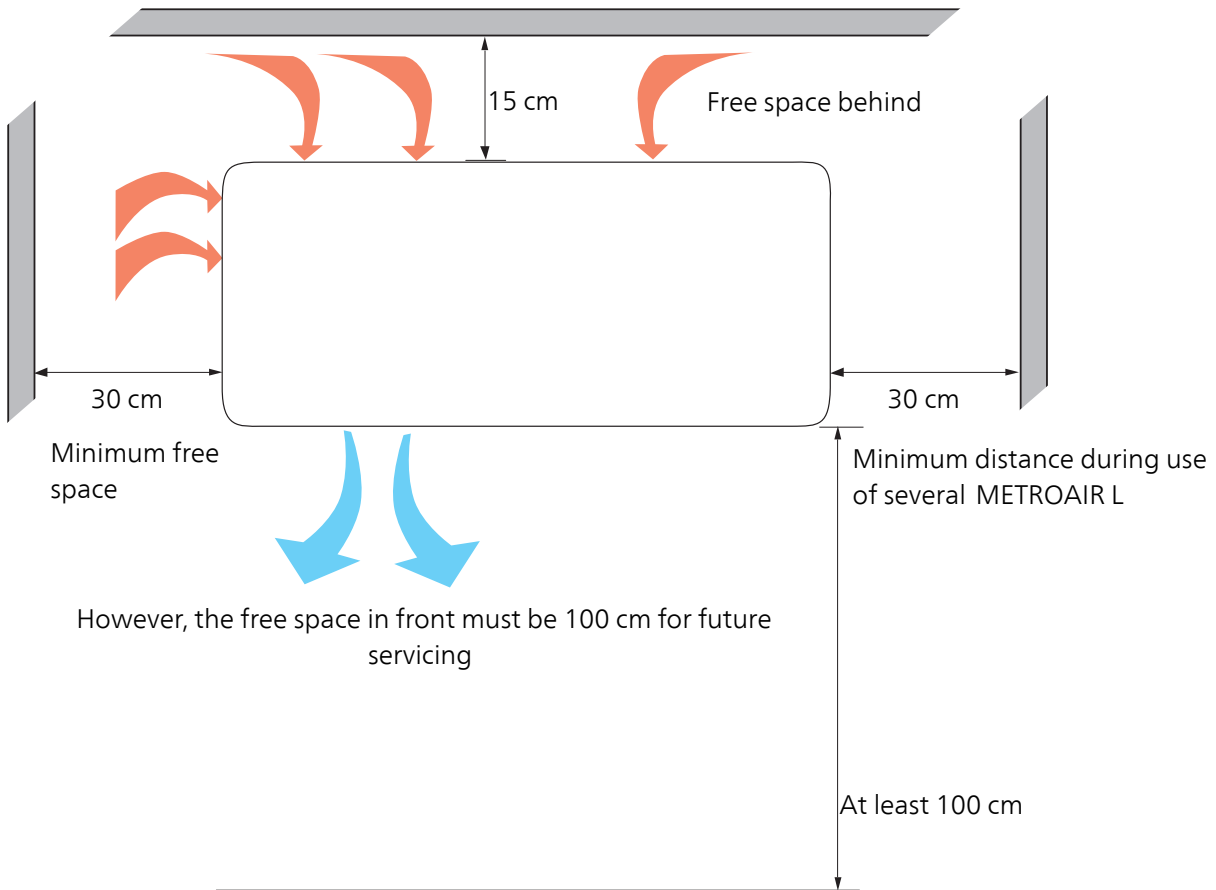

Removing the covers

METROAIR L6

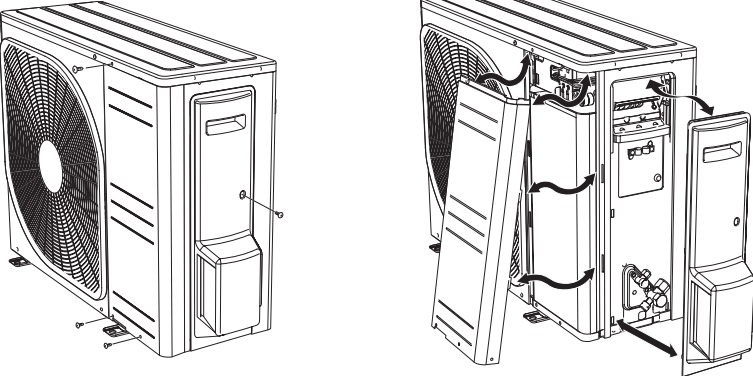

METROAIR L8

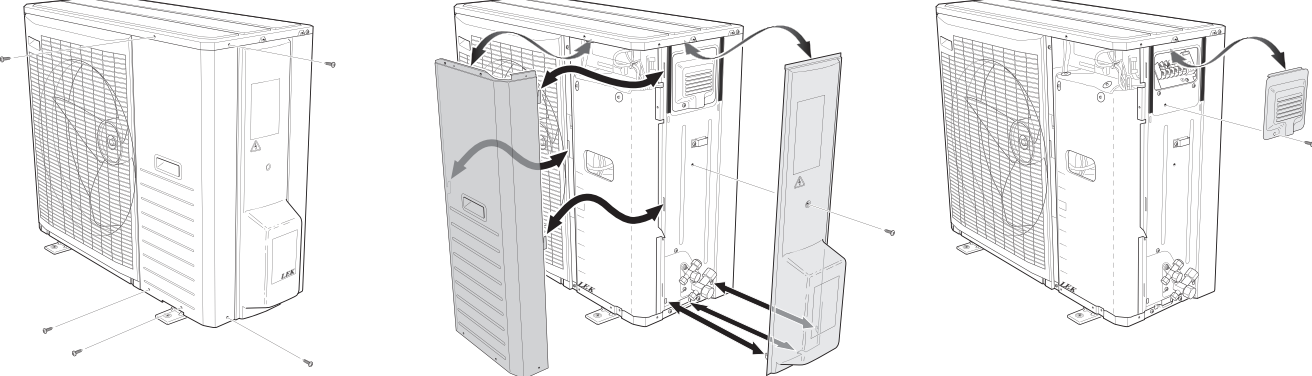

METROAIR L12

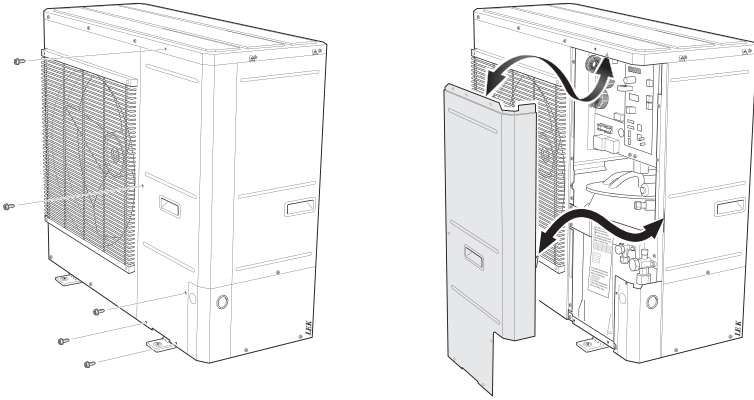

3 The heat pump design

Component locations METROAIR L6 (EZ101)

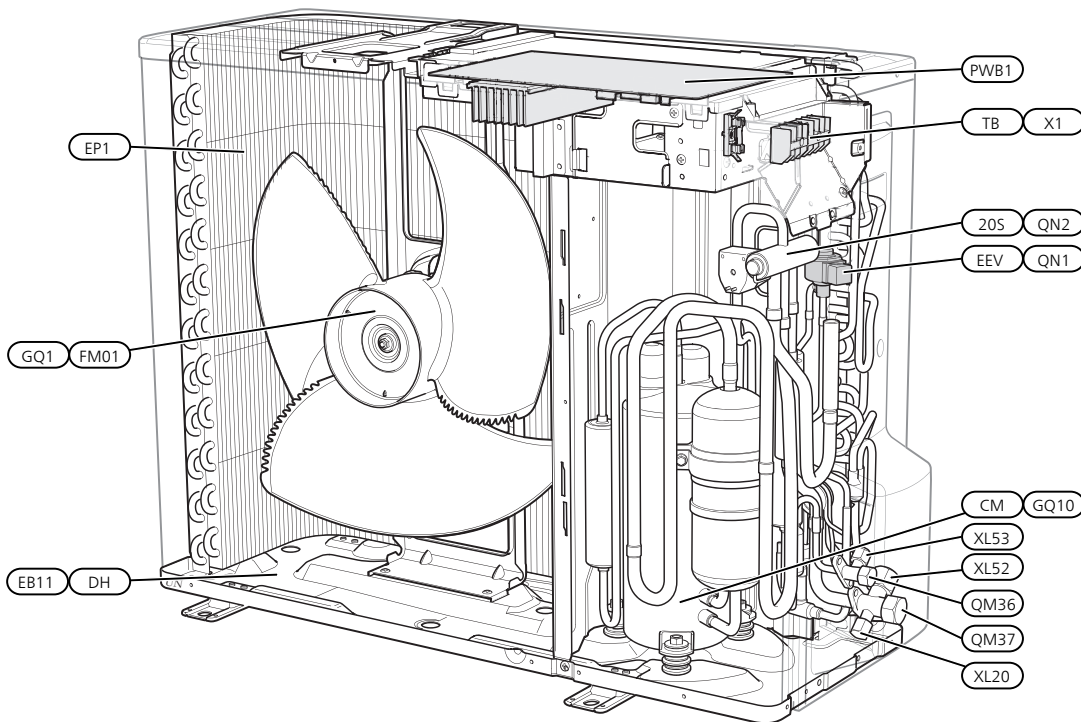

Component locations METROAIR L8 (EZ101)

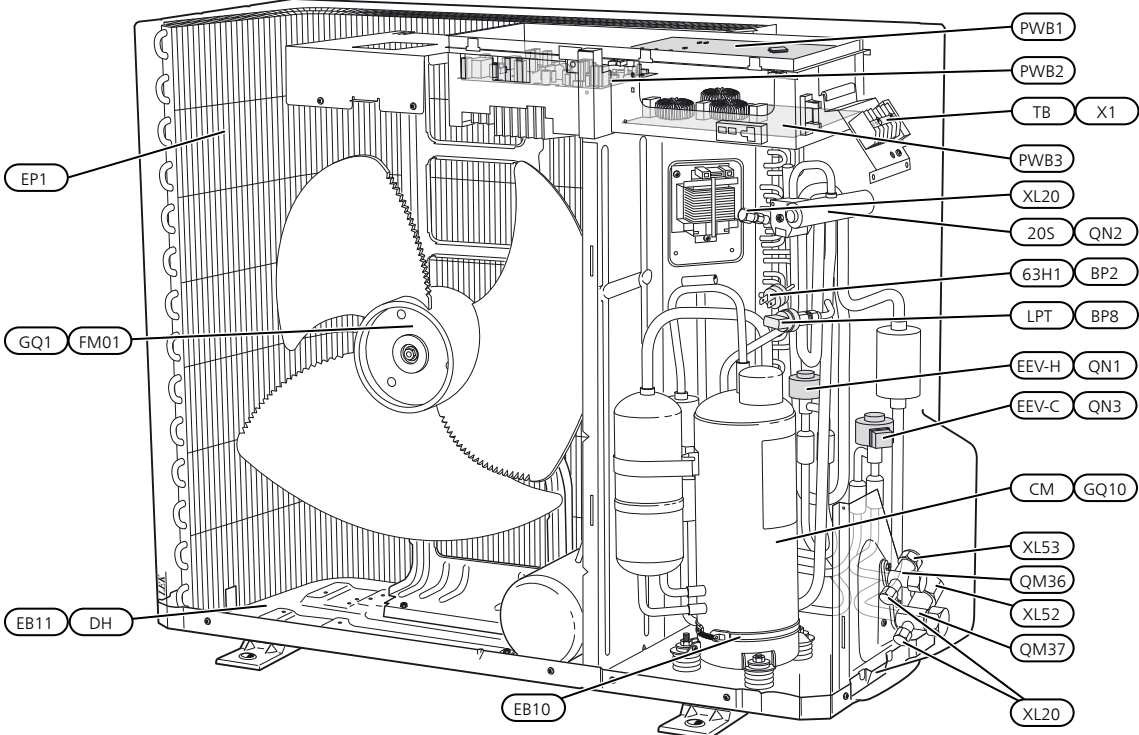

Component locations METROAIR L12 (EZ101)

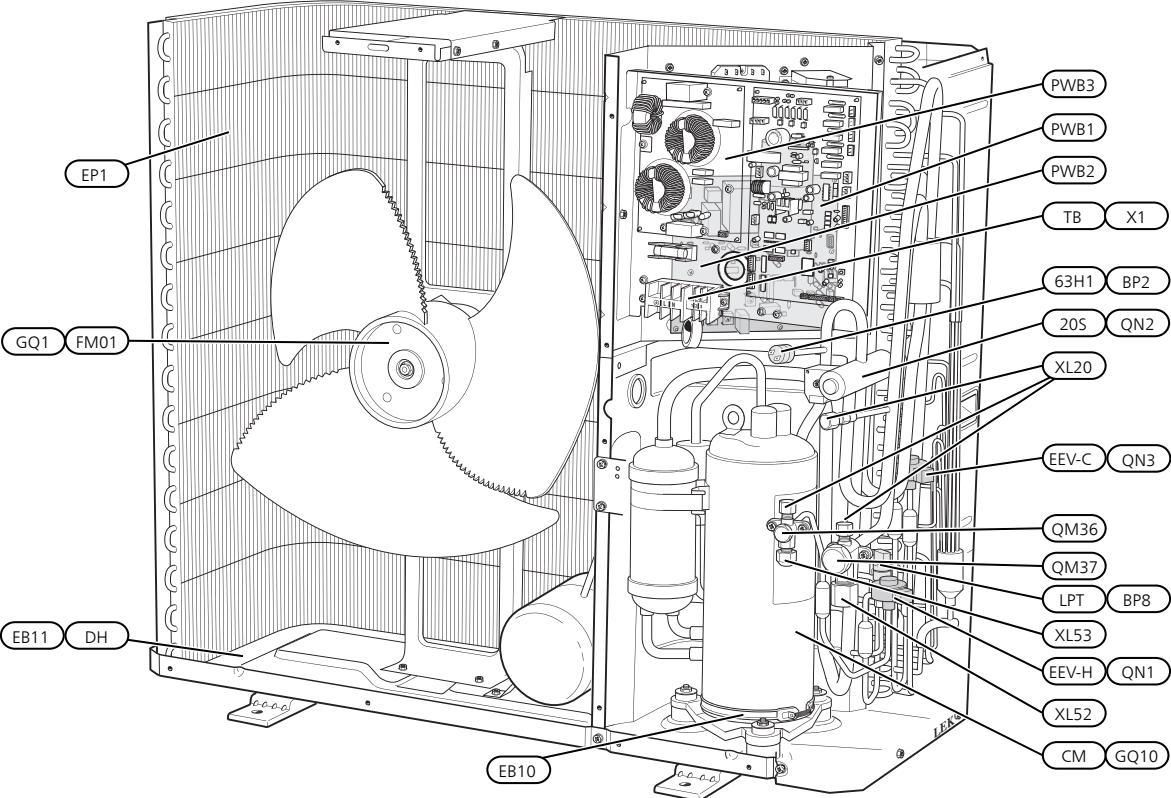

List of components

METROAIR L (EZ101)

PIPE CONNECTIONS

QM36	Service valve, liquid side
QM37	Service valve, gas side
XL20	Connection, service
XL52	Connection, gas line
XL53	Connection, liquid line

SENSORS ETC.

BP2 (63H1)	High pressure pressostat
BP8 (LPT)	Low pressure transmitter

ELECTRICAL COMPONENTS

EB11 (DH)	Drain pan heater
GQ1 (FM01)	Fan
GQ2 (FM02)	Fan
(PWB1)	Control board
(PWB2)	Inverter board
(PWB3)	Filter board
X1 (TB)	Terminal block, incoming supply and communication

COOLING COMPONENTS

EB10 (CH)	Compressor heater
EP1	Evaporator
GQ10 (CM)	Compressor
QN1 (EEV-H)	Expansion valve, heating
QN2(20S)	4-way valve
QN3 (EEV-C)	Expansion valve, cooling

MISCELLANEOUS

PF3	Serial number plate
-----	---------------------

Designations at component positions according to standard EN 81346-2.

Designations within brackets according to the supplier's standard.

Electrical panel

COMPONENT LOCATION METROAIR L
METROAIR L6

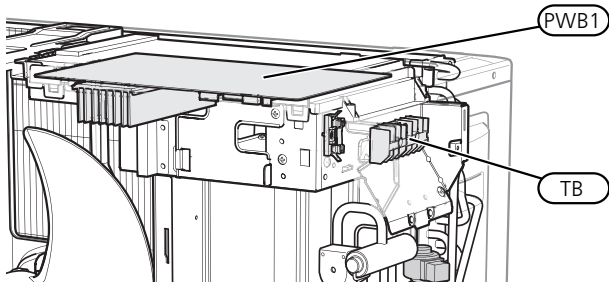

METROAIR L8

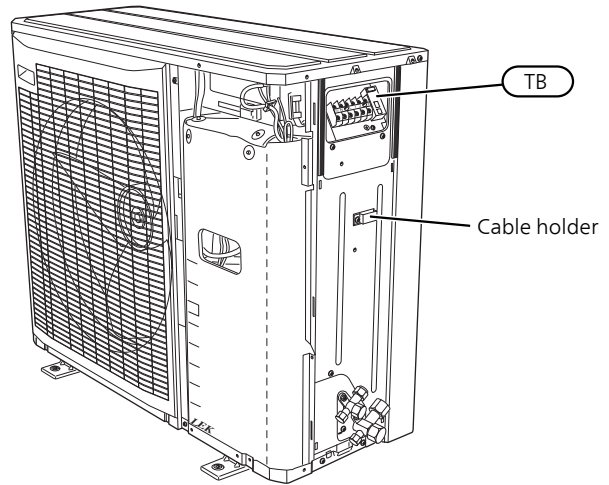
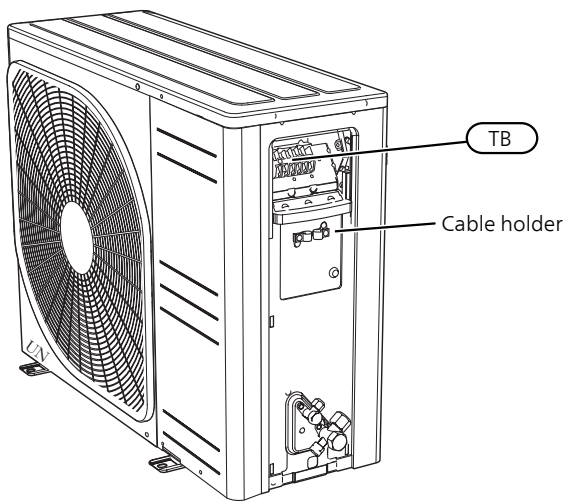
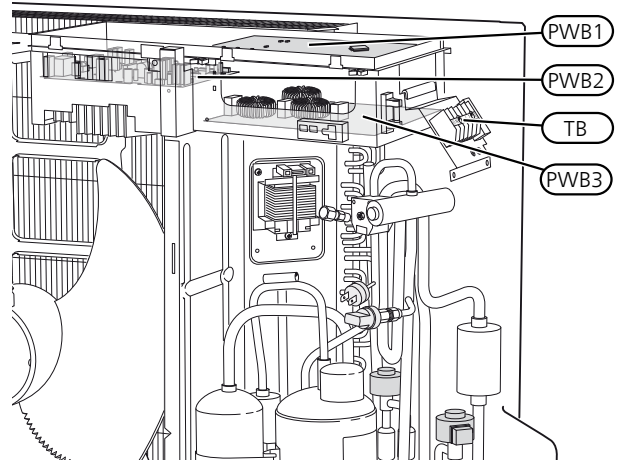

METROAIR L12

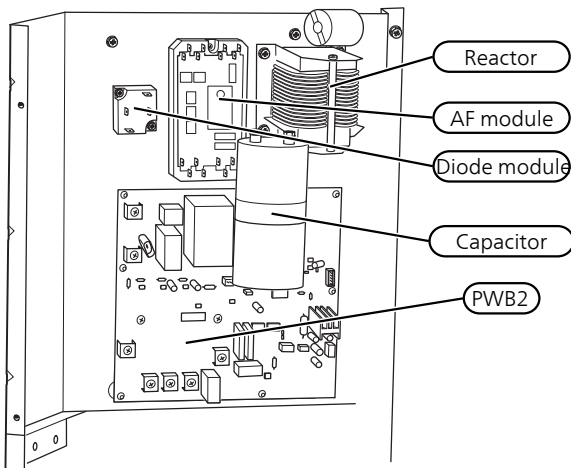
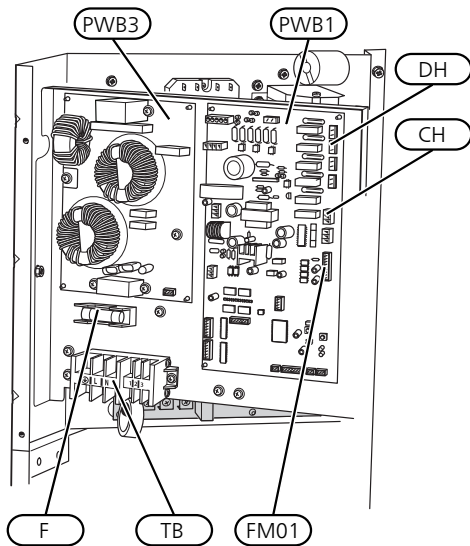

Electrical components METROAIR L

(CH)	Compressor heater
(DH)	Drain pan heater
F	Fuse
(FM01)	Fan motor
(PWB1)	Control board
(PWB2)	Inverter board
(PWB3)	Filter board
(TB)	Terminal block, incoming supply and communication

Designations at component positions according to standard EN 81346-2.
Designations within brackets according to the supplier's standard.

Sensor placement

POSITIONING THE TEMPERATURE SENSOR

Outdoor module METROAIR L6

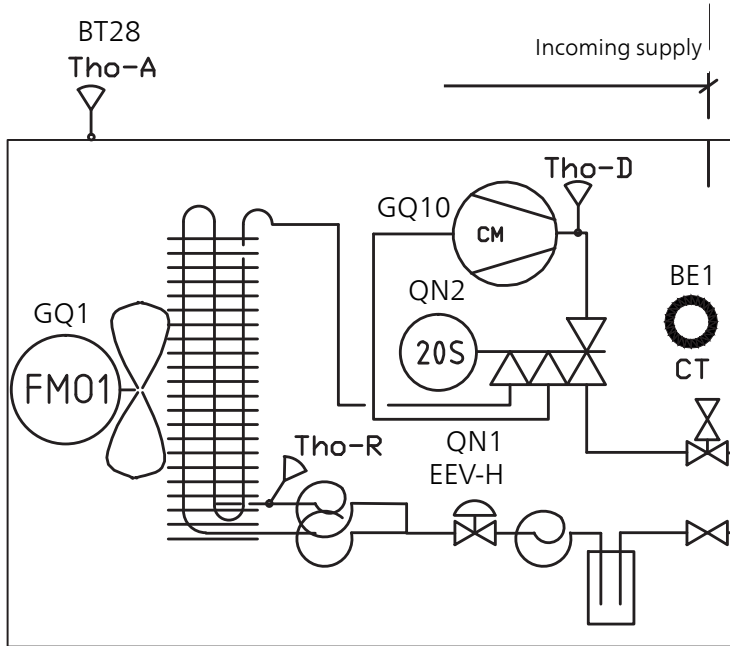

Outdoor module METROAIR L8-12

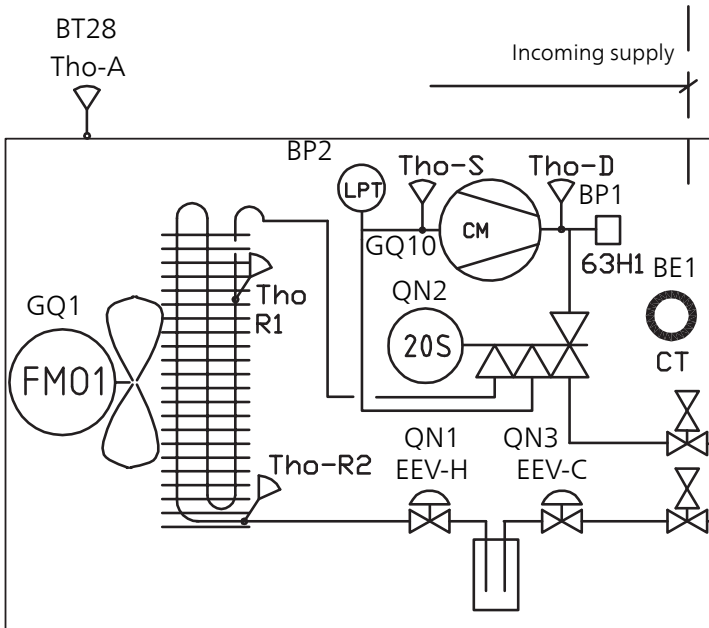

BE1 (CT)	Current sensor
BT28 (Tho-A)	Outdoor temperature
BP1 (63H1)	High pressure pressostat
BP2 (LPT)	Low pressure transmitter
GQ1 (FM01)	Fan
GQ2 (FM02)	Fan
GQ10 (CM)	Compressor
QN1 (EEV-H)	Expansion valve, heating
QN2 (20S)	4-way valve
QN3 (EEV-C)	Expansion valve, cooling
Tho-D	Hot gas sensor
Tho-R1	Evaporator sensor, out
Tho-R2	Evaporator sensor, in
Tho-S	Suction gas sensor

Designations at component positions according to standard EN 81346-2.

Designations within brackets according to the supplier's standard.

DATA FOR SENSOR IN METROAIR L6

Tho-D

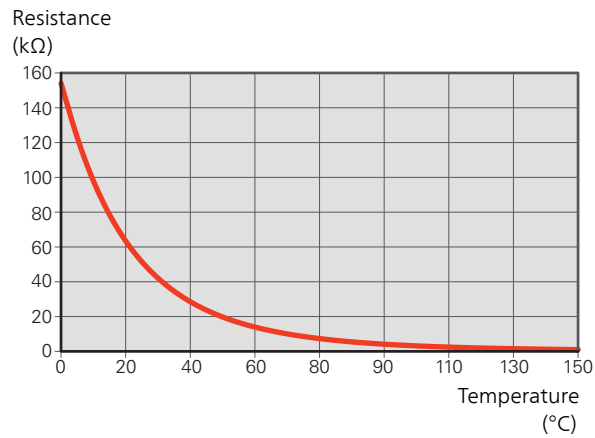

DATA FOR SENSOR IN METROAIR L8-12

Tho-D

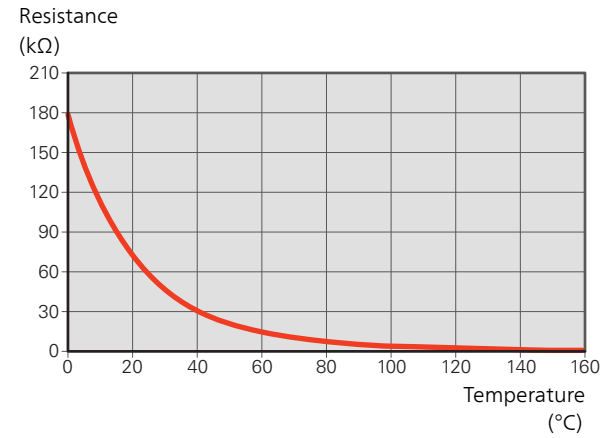

Tho-A, R

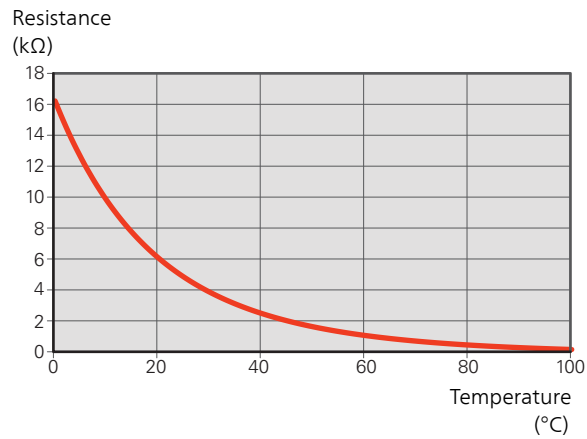

Tho-S, Tho-R1, Tho-R2

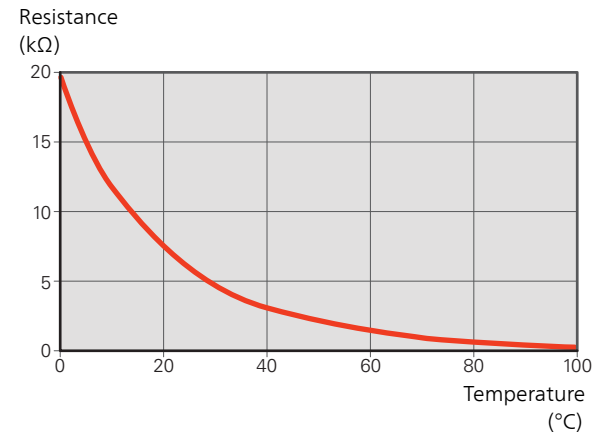

Tho-A (BT28)

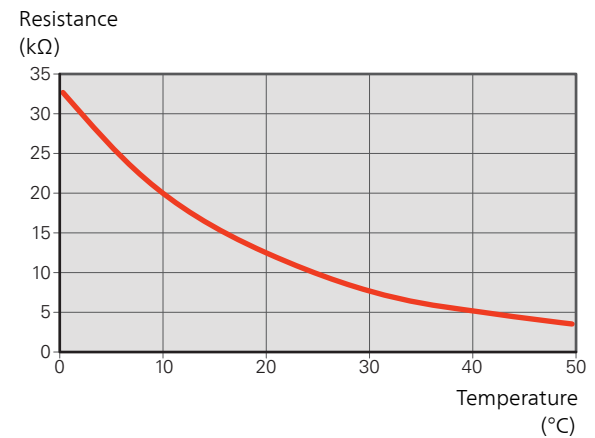

4 Pipe connections



NOTE

For information: See chapter “Pipe connections” in the Installer Manual for the indoor module.

5 Electrical connections

General

METROAIR L and indoor module does not include an omnipolar circuit breaker on the incoming power supply. Therefore, its supply cables must each be connected to their own circuit breaker with a breaking gap of at least 3 mm. Incoming supply must be 230V ~50Hz via electrical distribution board with fuses.

- Disconnect the indoor module and outdoor module METROAIR L before insulation testing the house wiring.
- For fuse ratings, see technical data, "Fuse protection".
- If the building is equipped with an earth-fault breaker, METROAIR L should be equipped with a separate one.
- Connection must not be carried out without the permission of the electricity supplier and under the supervision of a qualified electrician.
- Cables must be routed so that they are not damaged by metal edges or trapped by panels.
- METROAIR L is equipped with a single phase compressor. This means that one of the phases will be loaded with a number of amperes (A) during compressor operation. Check the maximum load in the table below.

<i>Outdoor module</i>	<i>Maximum current (A)</i>
METROAIR L6	15
METROAIR L8	16
METROAIR L12	16

- Maximum permitted phase loading can be restricted to a lower maximum current in the indoor module or control module.



NOTE

Electrical installation and any servicing must be carried out under the supervision of a qualified electrician. Disconnect the current with the circuit breaker before carrying out any servicing. Electrical installation and wiring must be carried out in accordance with the national stipulations in force.



NOTE

Check the connections, main voltage and phase voltage before starting the machine to prevent damage to the air/water heat pump's electronics.



NOTE

The live external control must be taken into consideration when connecting.



NOTE

If the supply cable is damaged, only authorised person may replace it to prevent any danger and damage.

Connections

! *NOTE*
To prevent interference, unscreened communication and/or sensor cables to external connections must not be laid closer than 20 cm from high voltage cables.

POWER CONNECTION METROAIR L

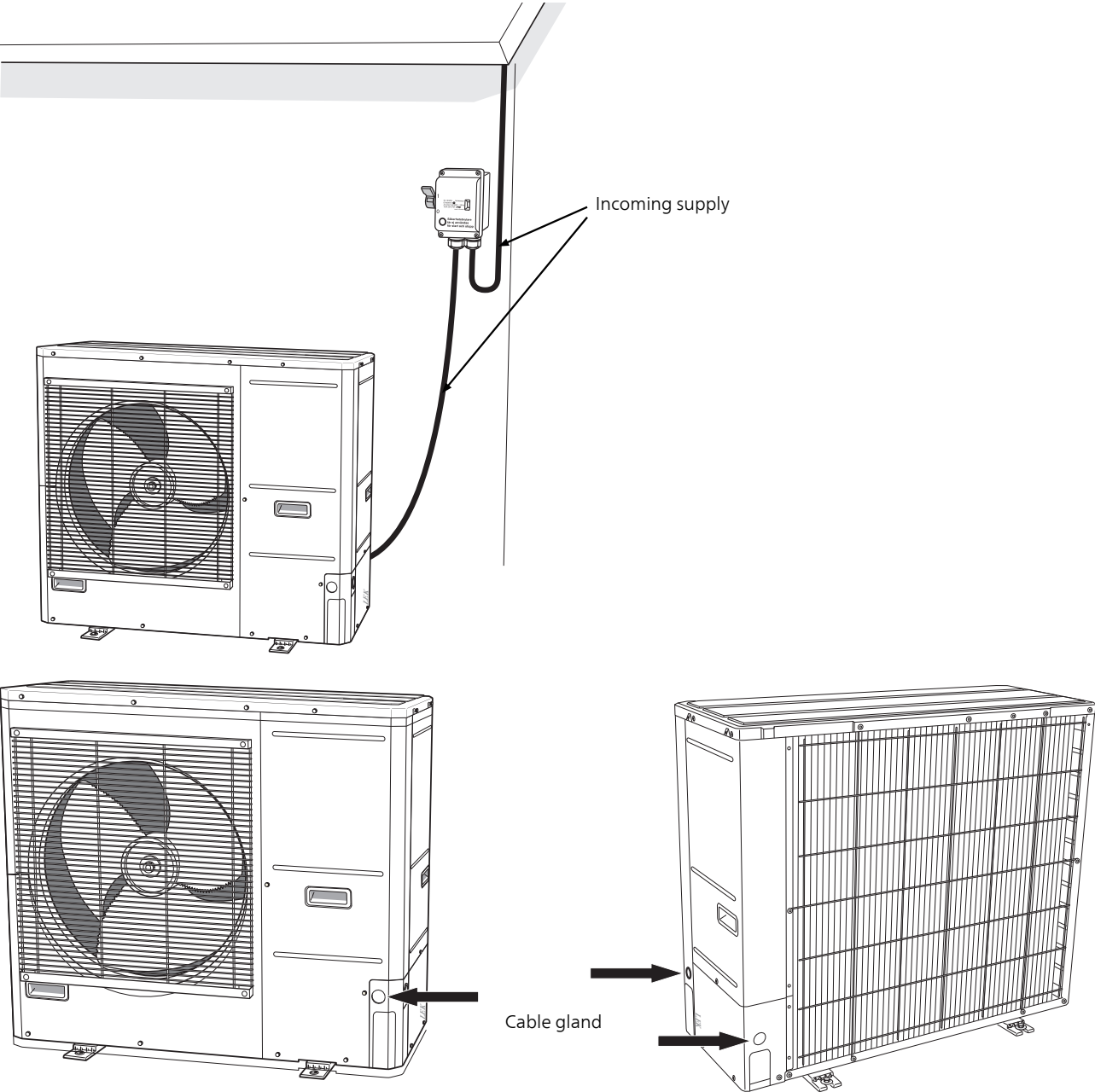

COMMUNICATION CONNECTION

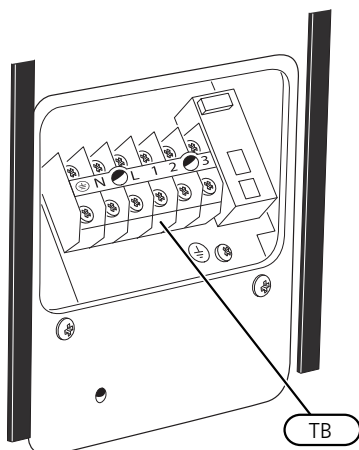

Communication is connected on terminal block TB. See also electrical wiring diagram on page 55.

You can find more information in the Installer Manual for the indoor module.

CONNECTING ACCESSORIES

Instructions for connecting accessories are in the installation instructions provided for the respective accessory.



NOTE

For more information: See chapter “Electrical connections” in the Installer Manual for the indoor module.

6 Commissioning and adjusting

Compressor heater

METROAIR L is equipped with a compressor heater (CH) that heats the compressor before start-up and when the compressor is cold. (Does not apply to METROAIR L6.)



NOTE

The compressor heater must have been connected for 6 – 8 hours before the first start, see the section “Start-up and inspection” in the Installer Manual for the indoor module or control module.



NOTE

For information: See chapter “Commissioning and adjustment” in the Installer Manual for the indoor module.

7 Control - Heat pump EB101



NOTE

For information: See chapter “Control – Heat pump EB101” in the Installer Manual for the indoor module.

8 Disturbances in comfort



NOTE

For more information: See chapter “Disturbances in comfort” in the Installer Manual for the indoor module.

9 Alarm list

<i>Alarm</i>	<i>Alarm text on the display</i>	<i>Description</i>	<i>May be due to</i>
162	High condenser out	Too high temperature out from the condenser. Self-resetting.	<ul style="list-style-type: none"> • Low flow during heating operation • Too high set temperatures
163	High condenser in	Too high temperature into the condenser. Self-resetting.	<ul style="list-style-type: none"> • Temperature generated by another heat source
183	Defrosting in progress	Not an alarm, but an operating status.	<ul style="list-style-type: none"> • Set when the heat pump runs the defrosting procedure
220	HP alarm	The high pressure switch (63H1) deployed 5 times within 60 minutes or for 60 minutes continuously.	<ul style="list-style-type: none"> • Insufficient air circulation or blocked heat exchanger • Open circuit or short circuit on input for high pressure switch (63H1) • Defective high pressure switch • Expansion valve not correctly connected • Service valve closed • Defective control board in METROAIR L • Low or no flow during heating operation • Defective circulation pump • Defective fuse, F(4A)
221	LP alarm	Too low a value on the low pressure sensor (LPT) 3 times within 60 minutes.	<ul style="list-style-type: none"> • Open circuit or short circuit on input for low pressure sensor • Defective low pressure sensor (LPT) • Defective control board in METROAIR L • Open circuit or short circuit on input for suction gas sensor (Tho-S) • Defective suction gas sensor (Tho-S)
223	OU Com. error	Communication between the control board and the communication board is interrupted. There must be 22 volt direct current (DC) at the switch CNW2 on the control board (PWB1).	<ul style="list-style-type: none"> • Any circuit breakers for METROAIR L off • Incorrect cable routing
224	Fan alarm	Deviations in the fan speed in AMS 10.	<ul style="list-style-type: none"> • The fan cannot rotate freely • Defective control board in METROAIR L • Defective fan motor • Control board in METROAIR L dirty • Fuse (F2) blown
230	Continuously high hot gas	Temperature deviation on the hot gas sensor (Tho-D) twice within 60 minutes or for 60 minutes continuously.	<ul style="list-style-type: none"> • Sensor does not work (see section "Communication connection") • Insufficient air circulation or blocked heat exchanger • If the fault persists during cooling, there may be an insufficient amount of refrigerant. • Defective control board in METROAIR L

<i>Alarm</i>	<i>Alarm text on the display</i>	<i>Description</i>	<i>May be due to</i>
254	Communication error	Communication fault with accessory board	<ul style="list-style-type: none"> • METROAIR L not powered • Fault in the communication cable.
261	High temperature in heat exchanger	Temperature deviation on the heat exchanger sensor (Tho-R1/R2) five times within 60 minutes or for 60 minutes continuously.	<ul style="list-style-type: none"> • Sensor does not work (see section "Disturbances in comfort") • Insufficient air circulation or blocked heat exchanger • Defective control board in METROAIR L • Too much refrigerant
262	Power transistor too hot	When IPM (Intelligent power module) displays FO-signal (Fault Output) five times during a 60-minute period.	<ul style="list-style-type: none"> • Can occur when 15V power supply to the inverter PCB is unstable.
263	Inverter error	Voltage from the inverter outside the parameters four times within 30 minutes.	<ul style="list-style-type: none"> • Incoming power supply interference • Service valve closed • Insufficient amount of refrigerant • Compressor fault • Defective circuit board for inverter in METROAIR L
264	Inverter error	Communication between circuit board for inverter and control board broken.	<ul style="list-style-type: none"> • Open circuit in connection between boards • Defective circuit board for inverter in METROAIR L • Defective control board in METROAIR L
265	Inverter error	Continuous deviation on power transistor for 15 minutes.	<ul style="list-style-type: none"> • Defective fan motor • Defective circuit board for inverter in METROAIR L
266	Insufficient refrigerant	Insufficient refrigerant is detected upon start-up in cooling mode.	<ul style="list-style-type: none"> • Service valve closed • Loose connection sensor (BT15, BT3) • Defective sensor (BT15, BT3) • Too little refrigerant
267	Inverter error	Failed start for compressor	<ul style="list-style-type: none"> • Defective circuit board for inverter in METROAIR L • Defective control board in METROAIR L • Compressor fault
268	Inverter error	Overcurrent, Inverter A/F module	<ul style="list-style-type: none"> • Sudden power failure
271	Cold outdoor air	Temperature of BT28 (Tho-A) below the set value that permits operation	<ul style="list-style-type: none"> • Cold weather conditions • Sensor fault
272	Hot outdoor air	Temperature of BT28 (Tho-A) above the value that permits operation	<ul style="list-style-type: none"> • Warm weather conditions • Sensor fault
277	Sensor fault Tho-R	Sensor fault, heat exchanger in METROAIR L (Tho-R).	<ul style="list-style-type: none"> • Open circuit or short circuit on sensor input • Sensor does not work (see section "Disturbances in comfort") • Defective control board in METROAIR L
278	Sensor fault Tho-A	Sensor fault, outdoor temperature sensor in METROAIR L BT28 (Tho-A).	<ul style="list-style-type: none"> • Open circuit or short circuit on sensor input • Sensor does not work (see section "Disturbances in comfort") • Defective control board in METROAIR L
279	Sensor fault Tho-D	Sensor fault, hot gas in METROAIR L (Tho-D)	<ul style="list-style-type: none"> • Open circuit or short circuit on sensor input • Sensor does not work (see section "Disturbances in comfort") • Defective control board in METROAIR L

<i>Alarm</i>	<i>Alarm text on the display</i>	<i>Description</i>	<i>May be due to</i>
280	Sensor fault Tho-S	Sensor fault, suction gas in METROAIR L (Tho-S).	<ul style="list-style-type: none"> • Open circuit or short circuit on sensor input • Sensor does not work (see section "Disturbances in comfort") • Defective control board in METROAIR L
281	Sensor fault LPT	Sensor fault, low pressure transmitter in METROAIR L .	<ul style="list-style-type: none"> • Open circuit or short circuit on sensor input • Sensor does not work (see section "Disturbances in comfort") • Defective control board in METROAIR L • Fault in the refrigerant circuit
294	Non-compatible outdoor air heat pump	Heat pump and indoor module do not work properly together due to technical parameters.	<ul style="list-style-type: none"> • Outdoor module and indoor module are not compatible.

10 Technical data

Dimensions

METROAIR L6

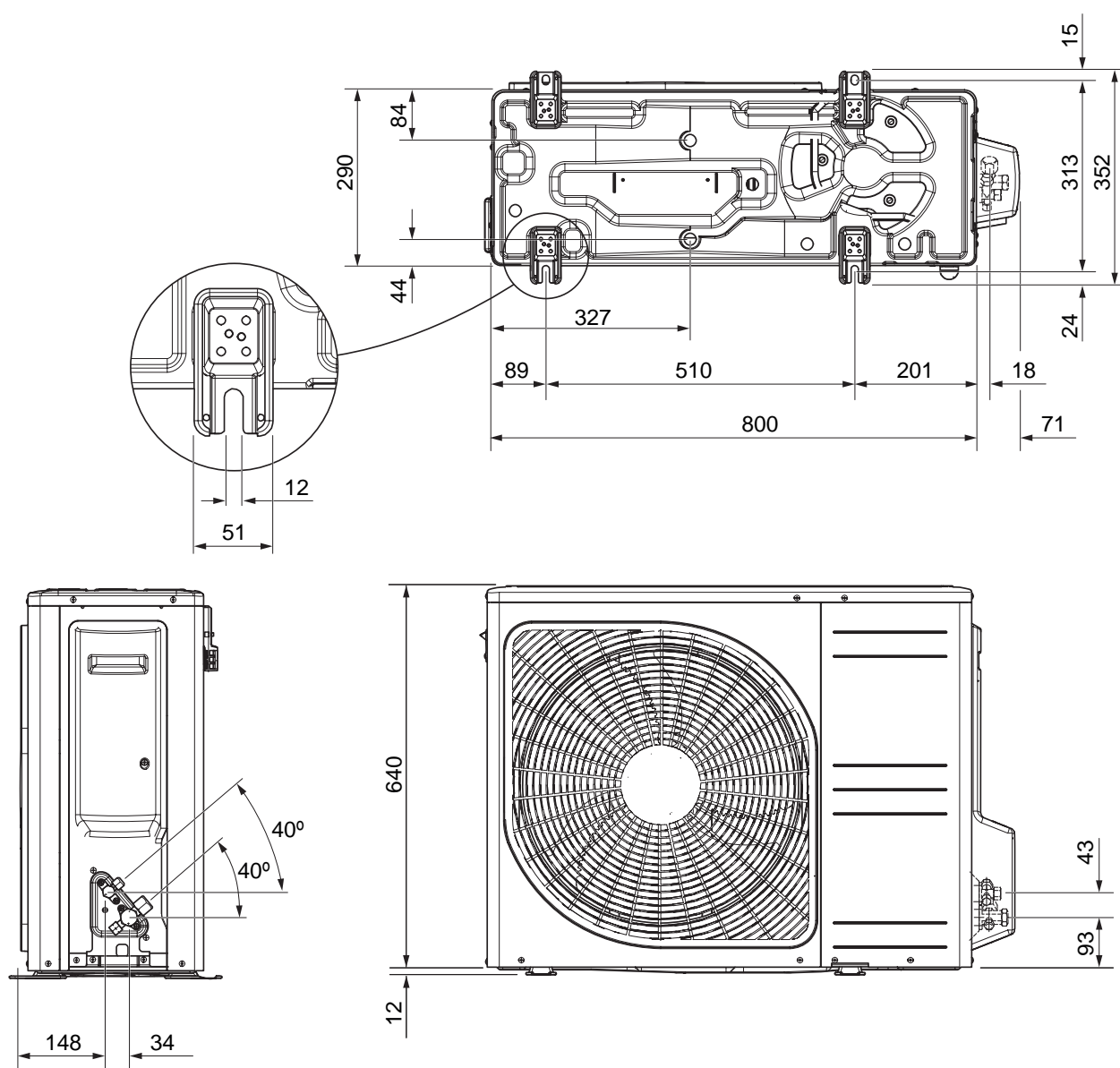

METROAIR L8

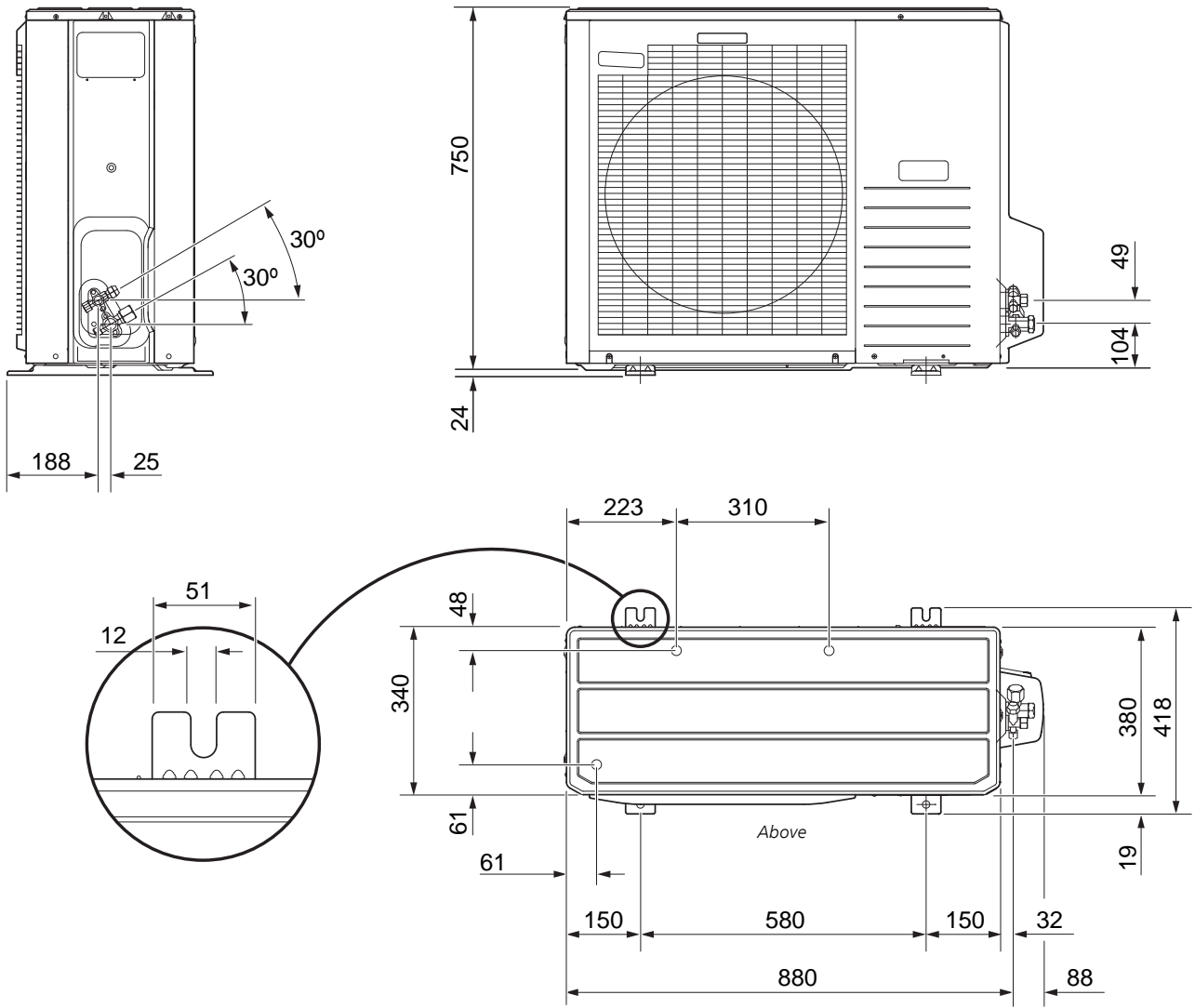

METROAIR L12

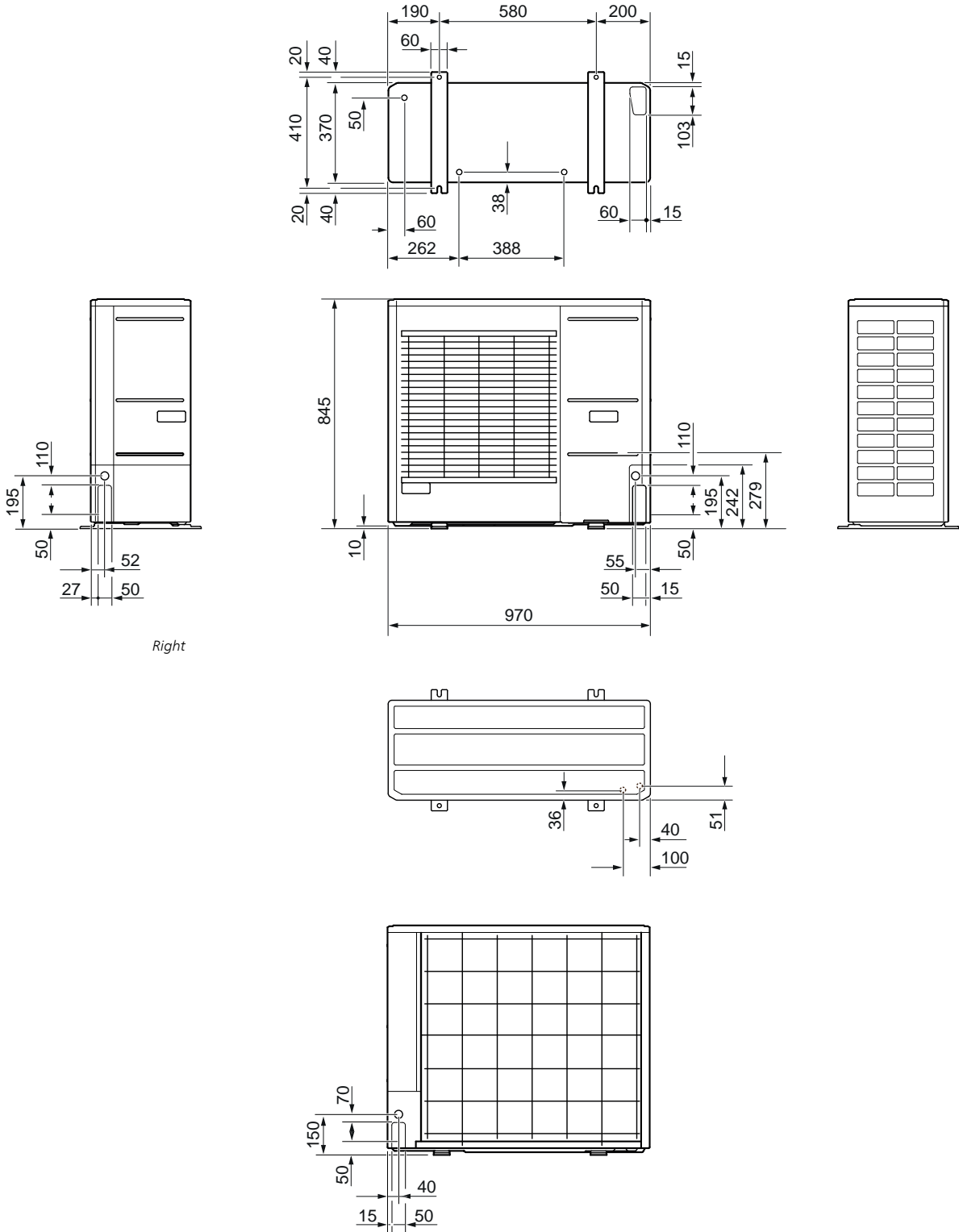

Right

Sound pressure levels

METROAIR L is usually placed next to a house wall, which gives a directed sound distribution that should be considered. Accordingly, you should always attempt

to find a placement on the side that faces the least sound sensitive neighbouring area.

The sound pressure levels are further affected by walls, bricks, differences in ground level, etc and should therefore only be seen as guide values.

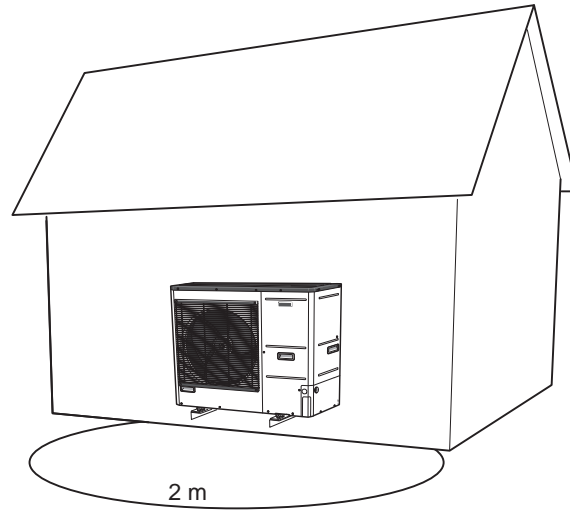

Noise		METROAIR L6	METROAIR L8	METROAIR L12
Sound power level, according to EN12102 at 7/35 °C (nominal)*	L _W (A)	51	55	58
Sound pressure level at 2 m free standing (nominal)*	dB(A)	37	41	44

* Free space.

Technical specifications



METROAIR L

Outdoor module		METROAIR L6	METROAIR L8	METROAIR L12
Output data according to EN 14511 $\Delta T5K$		Outdoor temp./ Supply temp.		
Heating Capacity / power input / COP (kW/kW/-) at nominal flow	7/35 °C (floor)	2.67/0.5/5.32	3.86/0.83/4.65	5.21/1.09/4.78
	2/35 °C (floor)	2.32/0.55/4.2	5.11/1.36/3.76	6.91/1.79/3.86
	-7/35 °C (floor)	4.60/1.79/2.57	6.60/2.46/2.68	9.00/3.27/2.75
	7/45 °C	2.28/0.63/3.62	3.70/1.00/3.70	5.00/1.31/3.82
	2/45 °C	1.93/0.67/2.88	5.03/1.70/2.96	6.80/2.24/3.04
Cooling Capacity / Power input / EER (kW/kW/-) at maximum flow	27/7 °C	5.87/1.65/3.56	7.52/2.37/3.17	9.87/3.16/3.13
	27/18 °C	7.98/1.77/4.52	11.20/3.20/3.50	11.70/3.32/3.52
	35/7 °C	4.86/1.86/2.61	7.10/2.65/2.68	9.45/3.41/2.77
	35/18 °C	7.03/2.03/3.45	9.19/2.98/3.08	11.20/3.58/3.12
Electrical data				
Rated voltage		230V 50 Hz, 230V 2AC 50Hz		
Max. current	A _{rms}	15	16	23
Recommended fuse rating	A _{rms}	16	16	25
Starting current	A _{rms}	5		
Max fan flow (heating, nominal)	m ³ /h	2,530	3,000	4,380
Fan rating	W	50	86	
Drain pan heater (integrated)	W	110	100	120
Defrosting	Reverse cycle			
Enclosure class	IP24			
Refrigerant circuit				
Type of refrigerant		R410A		
GWP refrigerant		2,088		
Compressor		Twin Rotary		
Refrigerant quantity	kg	1.5	2.55	2.90
CO ₂ equivalent	t	3.13	5.32	6.06
Cut-out value, pressure switch, high pressure	MPa (bar)	-	4.15 (41.5)	
Breaking value high pressure	MPa (bar)	4.5 (45)		
Cut-out value, pressure switch, low pressure (15 s)	MPa (bar)	-	0.079 MPa (0.79)	
Max. length, refrigerant pipe, one way	m	30*		
Max height difference, refrigerant pipe	m	7		
Dimensions, refrigerant pipe		Gas pipe: OD12.7 (1/2") Fluid pipe: OD6.35 (1/4")	Gas pipe: OD15.88 (5/8") Fluid pipe: OD9.52 (3/8")	
Pipe connections				
Pipe connection option		Right-hand side	Right-hand side	Right / bottom / reverse
Pipe connections		Flare		
Dimensions and weight				
Width	mm	800	880 (+67 valve protection)	970
Depth	mm	290	340 (+ 110 with foot rail)	370 (+ 80 with foot rail)
Height	mm	640	750	845
Weight	kg	46	60	74

*METROAIR L6: If the length of the refrigerant pipes exceeds 15 m, extra refrigerant must be added at a rate of 0.02 kg/m.

METROAIR L8-12: If the length of the refrigerant pipes exceeds 15 metres, extra refrigerant must be added at a rate of 0.06 kg/m.

SCOP & PDESIGNH

<i>SCOP & P_{designh} METROAIR L according to EN 14825</i>						
<i>Outdoor module / Indoor module</i>	<i>METROAIR L6/ SHK 200S-6</i>		<i>METROAIR L8/ SHK 200S</i>		<i>METROAIR L12/ SHK 200S</i>	
	<i>P_{designh}</i>	<i>SCOP</i>	<i>P_{designh}</i>	<i>SCOP</i>	<i>P_{designh}</i>	<i>SCOP</i>
SCOP 35 Average climate	4.8	4.8	8.2	4.38	11.5	4.43
SCOP 55 Average climate	5,3	3.46	7.0	3.25	10	3,38
SCOP 35 Cold climate	4,0	3,65	9	3,55	11,5	3,63
SCOP 55 Cold climate	5,6	2,97	10	2,78	13	2,85
SCOP 35 Warm climate	4,2	6,45	8	5,7	12	5,8
SCOP 55 Warm climate	4,76	4,58	8	4,58	12	4,7

ENERGY RATING, AVERAGE CLIMATE

<i>Model</i>		<i>METROAIR L6/ SHK 200S-6</i>	<i>METROAIR L8/ SHK 200S</i>	<i>METROAIR L12/ SHK 200S</i>
<i>Control module model</i>		<i>SMO</i>	<i>SMO</i>	<i>SMO</i>
<i>Temperature application</i>	<i>°C</i>	<i>35 / 55</i>	<i>35 / 55</i>	<i>35 / 55</i>
The product's room heating efficiency class ¹⁾		<i>A++ / A++</i>	<i>A++ / A++</i>	<i>A++ / A++</i>
Space heating efficiency class of the system ²⁾		<i>A+++ / A++</i>	<i>A+++ / A++</i>	<i>A+++ / A++</i>

¹Scale for the product's room heating efficiency class A++ to G.

²Scale for the system's room heating efficiency class A+++ to G.

The reported efficiency of the package also takes the controller into account. If an external supplementary boiler or solar heating is added to the package, the overall efficiency of the package should be recalculated.

Working area

Compressor operation – heating

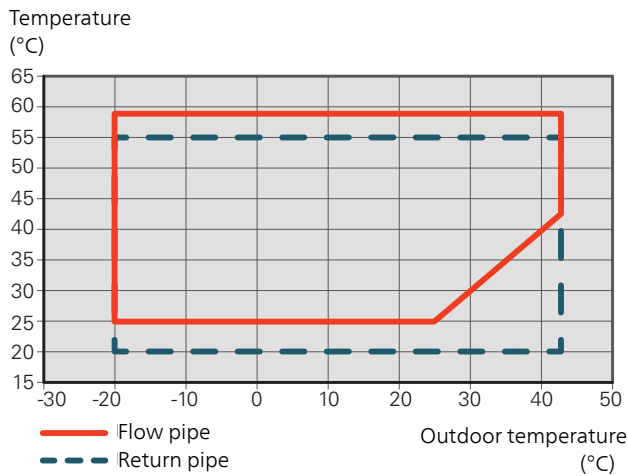

During shorter time it is allowed to have lower working temperatures on the water side, e.g. during start up.

Compressor operation – cooling

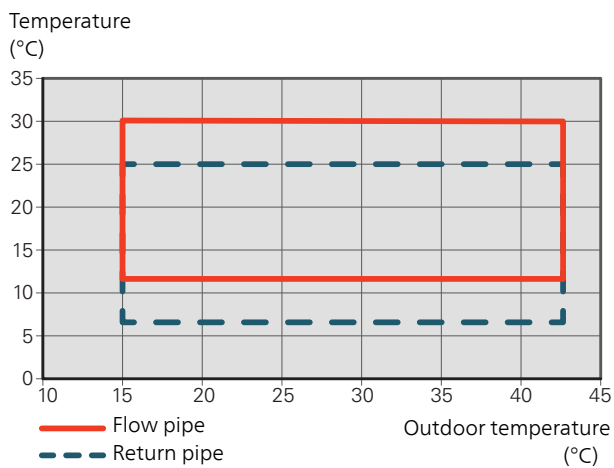

Capacity and COP

Capacity and COP at different supply temperatures. Maximum capacity including defrosting.

Max. specified power METROAIR L6

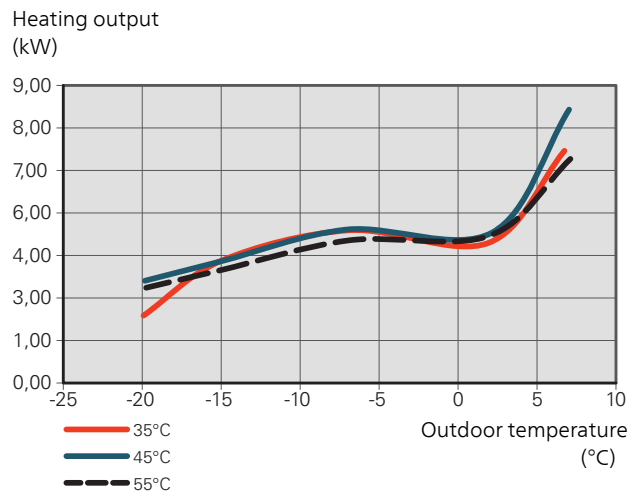

COP METROAIR L6

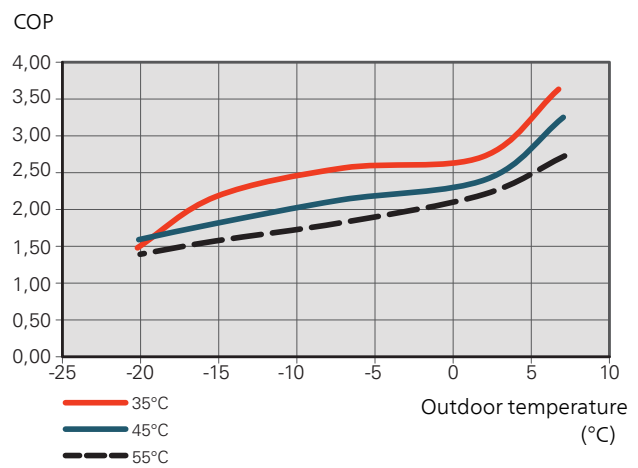

Max. specified power METROAIR L8

Heating output
(kW)

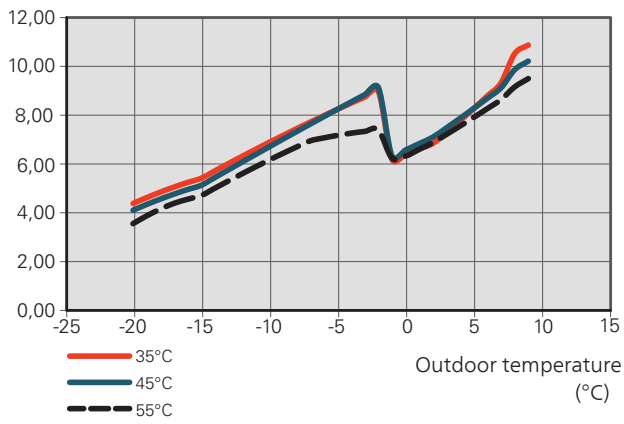

Max. specified power METROAIR L12

Heating output
(kW)

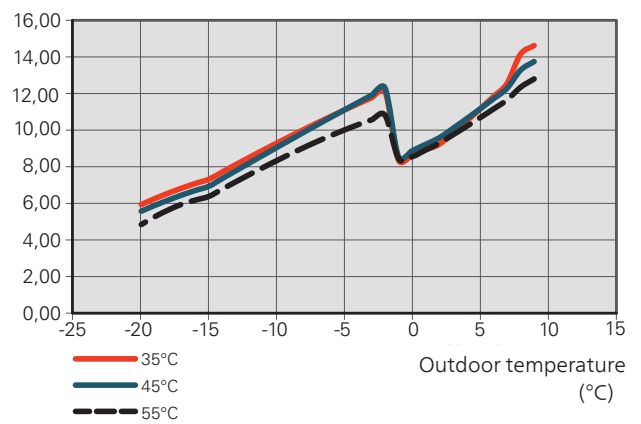

COP METROAIR L8

COP

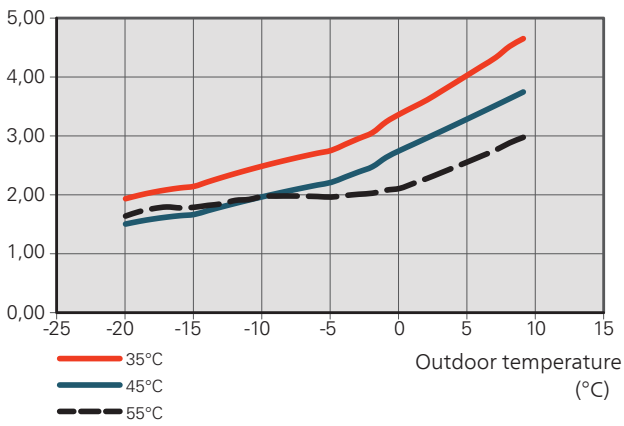

COP METROAIR L12

COP

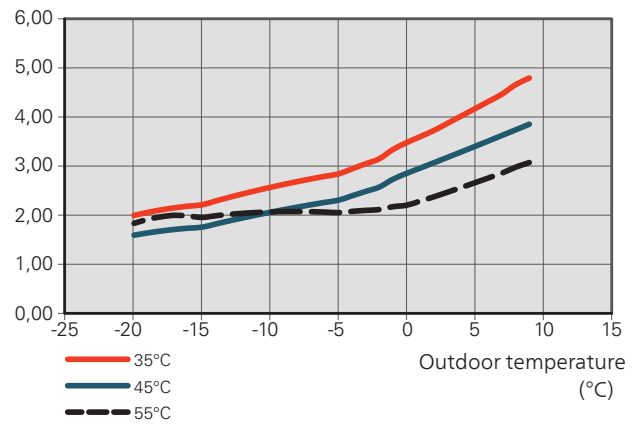

Output with lower fuse rating than recommended

Capacity METROAIR L12, fuse rating 16A

Heating output (kW)

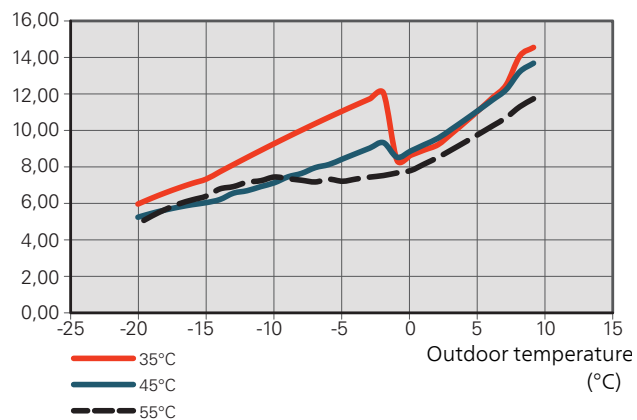

Capacity METROAIR L12, fuse rating 20A

Heating output (kW)

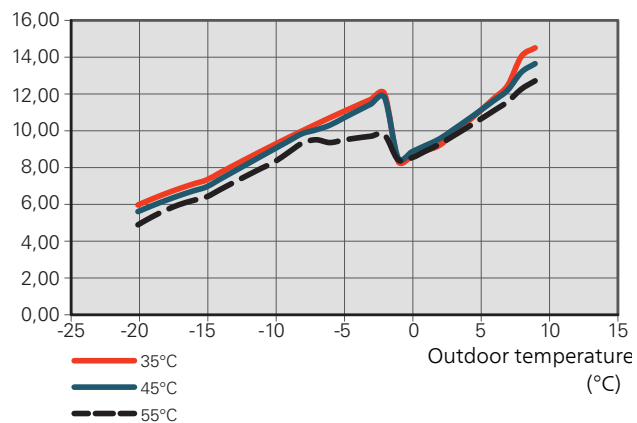

Energy labelling

INFORMATION SHEET

Supplier		METRO THERM		
Model		METROAIR L6 / SHK 2005-6	METROAIR L8 / SHK 2005	METROAIR L12 / SHK 2005
Temperature application	°C	35 / 55	35 / 55	35 / 55
Seasonal space heating energy efficiency class, average climate		A++ / A++	A++ / A++	A++ / A++
Rated heat output (P _{designh}), average climate	kW	5 / 5	8 / 7	12 / 10
Annual energy consumption space heating, average climate	kWh	2,089 / 3,248	3,882 / 4,447	5,382 / 6,136
Seasonal space heating energy efficiency, average climate	%	188 / 131	172 / 127	174 / 132
Sound power level L _{VVA} indoors	dB	35	35	35
Rated heat output (P _{designh}), cold climate	kW	4 / 6	9 / 10	12 / 13
Rated heat output (P _{designh}), warm climate	kW	4 / 5	8 / 8	12 / 12
Annual energy consumption space heating, cold climate	kWh	2,694 / 4,610	6,264 / 8,844	7,798 / 11,197
Annual energy consumption space heating, warm climate	kWh	872 / 1,398	1,879 / 2,333	2,769 / 3,419
Seasonal space heating energy efficiency, cold climate	%	143 / 116	139 / 108	142 / 111
Seasonal space heating energy efficiency, warm climate	%	252 / 179	225 / 180	229 / 185
Sound power level L _{VVA} outdoors	dB	51	55	58

DATA FOR ENERGY EFFICIENCY OF THE PACKAGE

Model		METROAIR L6 / SHK 2005-6	METROAIR L8 / SHK 2005	METROAIR L12 / SHK 2005
Control module model		SMO	SMO	SMO
Temperature application	°C	35 / 55	35 / 55	35 / 55
Controller, class		VI		
Controller, contribution to efficiency	%	4.0		
Seasonal space heating energy efficiency of the package, average climate	%	192 / 135	176 / 131	178 / 136
Seasonal space heating energy efficiency class of the package, average climate		A+++ / A++	A+++ / A++	A+++ / A++
Seasonal space heating energy efficiency of the package, cold climate	%	147 / 120	143 / 112	146 / 115
Seasonal space heating energy efficiency of the package, warm climate	%	256 / 183	229 / 184	233 / 189

The reported efficiency of the package also takes the controller into account. If an external supplementary boiler or solar heating is added to the package, the overall efficiency of the package should be recalculated.

TECHNICAL DOCUMENTATION

Model		METROAIR L6 / SHK 200S-6							
Type of heat pump		Air-water Exhaust-water Brine-water Water-water							
Low-temperature heat pump		Yes No							
Integrated immersion heater for additional heat		Yes No							
Heat pump combination heater		Yes No							
Climate		Average Cold Warm							
Temperature application		Average (55 °C) Low (35 °C)							
Applied standards		EN14511 / EN14825 / EN12102							
Rated heat output		Prated	5.3	kW	Seasonal space heating energy efficiency		η_s	131	%
Declared capacity for space heating at part load and at outdoor temperature T_j					Declared coefficient of performance for space heating at part load and at outdoor temperature T_j				
$T_j = -7\text{ °C}$	Pdh	4.7	kW	$T_j = -7\text{ °C}$	COPd	1.88	-		
$T_j = +2\text{ °C}$	Pdh	2.8	kW	$T_j = +2\text{ °C}$	COPd	3.26	-		
$T_j = +7\text{ °C}$	Pdh	1.8	kW	$T_j = +7\text{ °C}$	COPd	4.72	-		
$T_j = +12\text{ °C}$	Pdh	2.7	kW	$T_j = +12\text{ °C}$	COPd	6.47	-		
$T_j = \text{biv}$	Pdh	4.7	kW	$T_j = \text{biv}$	COPd	1.88	-		
$T_j = \text{TOL}$	Pdh	4.1	kW	$T_j = \text{TOL}$	COPd	1.77	-		
$T_j = -15\text{ °C}$ (if TOL < -20 °C)	Pdh		kW	$T_j = -15\text{ °C}$ (if TOL < -20 °C)	COPd		-		
Bivalent temperature		T_{biv}	-7	°C	Min. outdoor air temperature		TOL	-10	°C
Cycling interval capacity		P _{psych}		kW	Cycling interval efficiency		COP _{psych}		-
Degradation coefficient		Cdh	0.99	-	Max supply temperature		WTOL	58	°C
Power consumption in modes other than active mode					Additional heat				
Off mode		P _{OFF}	0.007	kW	Rated heat output		P _{sup}	1.2	kW
Thermostat-off mode		P _{TO}	0.012	kW					
Standby mode		P _{SB}	0.012	kW	Type of energy input		Electric		
Crankcase heater mode		P _{CK}	0	kW					
Other items									
Capacity control		Variable			Rated airflow (air-water)			2,526	m ³ /h
Sound power level, indoors/outdoors		L _{WA}	35 / 51	dB	Nominal heating medium flow				m ³ /h
Annual energy consumption		Q _{HE}	3,248	kWh	Brine flow brine-water or water-water heat pumps				m ³ /h
Contact information		METRO THERM A/S - Rundinsvej 55 - 3200 Helsingø - Denmark							

Model		METROAIR L8 / SHK 200S					
Type of heat pump	Air-water Exhaust-water Brine-water Water-water						
Low-temperature heat pump	Yes No						
Integrated immersion heater for additional heat	Yes No						
Heat pump combination heater	Yes No						
Climate	Average Cold Warm						
Temperature application	Average (55 °C) Low (35 °C)						
Applied standards	EN14825 / EN14511 / EN12102						
Rated heat output	Prated	7	kW	Seasonal space heating energy efficiency	η_s	127	%
Declared capacity for space heating at part load and at outdoor temperature T_j				Declared coefficient of performance for space heating at part load and at outdoor temperature T_j			
$T_j = -7\text{ °C}$	Pdh	6.3	kW	$T_j = -7\text{ °C}$	COPd	1.94	-
$T_j = +2\text{ °C}$	Pdh	3.9	kW	$T_j = +2\text{ °C}$	COPd	3.11	-
$T_j = +7\text{ °C}$	Pdh	2.6	kW	$T_j = +7\text{ °C}$	COPd	4.42	-
$T_j = +12\text{ °C}$	Pdh	3.7	kW	$T_j = +12\text{ °C}$	COPd	5.93	-
$T_j = \text{biv}$	Pdh	6.6	kW	$T_j = \text{biv}$	COPd	1.83	-
$T_j = \text{TOL}$	Pdh	5.9	kW	$T_j = \text{TOL}$	COPd	1.86	-
$T_j = -15\text{ °C}$ (if TOL < -20 °C)	Pdh		kW	$T_j = -15\text{ °C}$ (if TOL < -20 °C)	COPd		-
Bivalent temperature	T_{biv}	-9	°C	Min. outdoor air temperature	TOL	-10	°C
Cycling interval capacity	P _{cy}		kW	Cycling interval efficiency	COP _{cy}		-
Degradation coefficient	Cdh	0.97	-	Max supply temperature	WTOL	58	°C
Power consumption in modes other than active mode				Additional heat			
Off mode	P _{OFF}	0.002	kW	Rated heat output	P _{sup}	1.1	kW
Thermostat-off mode	P _{TO}	0.010	kW				
Standby mode	P _{SB}	0.015	kW	Type of energy input	Electric		
Crankcase heater mode	P _{CK}	0.030	kW				
Other items							
Capacity control	Variable			Rated airflow (air-water)		3,000	m ³ /h
Sound power level, indoors/outdoors	L _{WA}	35 / 55	dB	Nominal heating medium flow		0.60	m ³ /h
Annual energy consumption	Q _{HE}	4,447	kWh	Brine flow brine-water or water-water heat pumps			m ³ /h
Contact information	METRO THERM AVS - Rundinsvej 55 - 3200 Helsingø - Denmark						

Model		METROAIR L12 / SHK 200S					
Type of heat pump	Air-water Exhaust-water Brine-water Water-water						
Low-temperature heat pump	Yes No						
Integrated immersion heater for additional heat	Yes No						
Heat pump combination heater	Yes No						
Climate	Average Cold Warm						
Temperature application	Average (55 °C) Low (35 °C)						
Applied standards	EN14825 / EN14511 / EN12102						
Rated heat output	Prated	10	kW	Seasonal space heating energy efficiency	η_s	132	%
Declared capacity for space heating at part load and at outdoor temperature T_j				Declared coefficient of performance for space heating at part load and at outdoor temperature T_j			
$T_j = -7\text{ °C}$	Pdh	8.9	kW	$T_j = -7\text{ °C}$	COPd	1.99	-
$T_j = +2\text{ °C}$	Pdh	5.5	kW	$T_j = +2\text{ °C}$	COPd	3.22	-
$T_j = +7\text{ °C}$	Pdh	3.5	kW	$T_j = +7\text{ °C}$	COPd	4.61	-
$T_j = +12\text{ °C}$	Pdh	5.0	kW	$T_j = +12\text{ °C}$	COPd	6.25	-
$T_j = \text{biv}$	Pdh	9.2	kW	$T_j = \text{biv}$	COPd	1.90	-
$T_j = \text{TOL}$	Pdh	8.1	kW	$T_j = \text{TOL}$	COPd	1.92	-
$T_j = -15\text{ °C}$ (if TOL < -20 °C)	Pdh		kW	$T_j = -15\text{ °C}$ (if TOL < -20 °C)	COPd		-
Bivalent temperature	T_{biv}	-8	°C	Min. outdoor air temperature	TOL	-10	°C
Cycling interval capacity	P _{cy}		kW	Cycling interval efficiency	COP _{cy}		-
Degradation coefficient	Cdh	0.98	-	Max supply temperature	WTOL	58	°C
Power consumption in modes other than active mode				Additional heat			
Off mode	P _{OFF}	0.002	kW	Rated heat output	P _{sup}	1.9	kW
Thermostat-off mode	P _{TO}	0.014	kW				
Standby mode	P _{SB}	0.015	kW	Type of energy input	Electric		
Crankcase heater mode	P _{CK}	0.035	kW				
Other items							
Capacity control	Variable			Rated airflow (air-water)		4,380	m ³ /h
Sound power level, indoors/outdoors	L _{WA}	35 / 58	dB	Nominal heating medium flow		0.86	m ³ /h
Annual energy consumption	Q _{HE}	6,136	kWh	Brine flow brine-water or water-water heat pumps			m ³ /h
Contact information	METRO THERM AVS - Rundinsvej 55 - 3200 Helsingør - Denmark						

Electrical circuit diagram

METROAIR L6

POWER SOURCE
1 PHASE
220-240V 50Hz
220V 60Hz

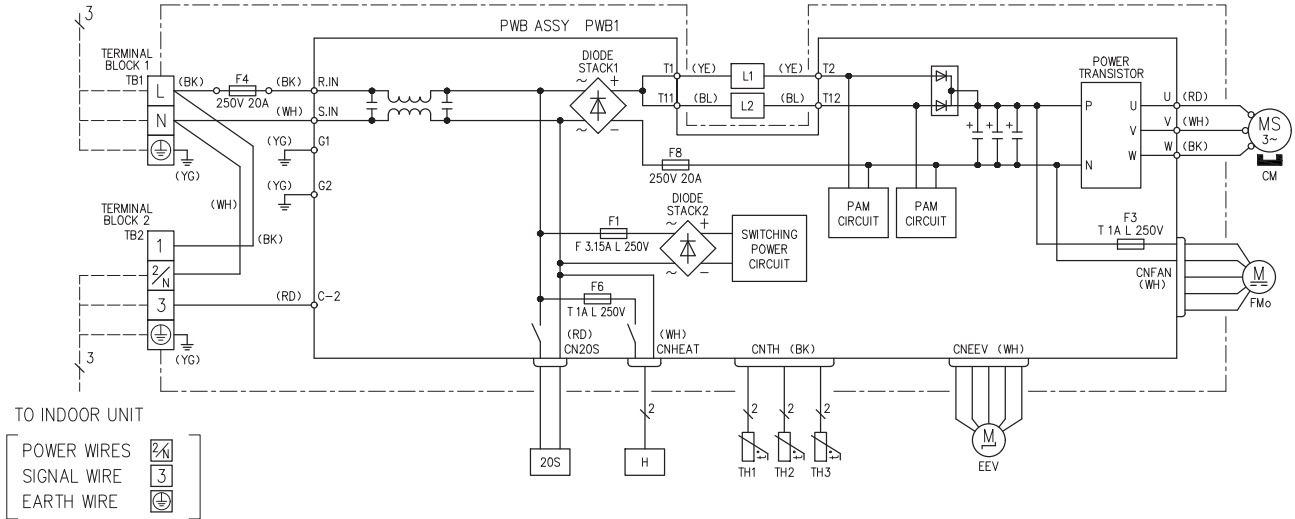

METROAIR L8

230V ~ 50Hz

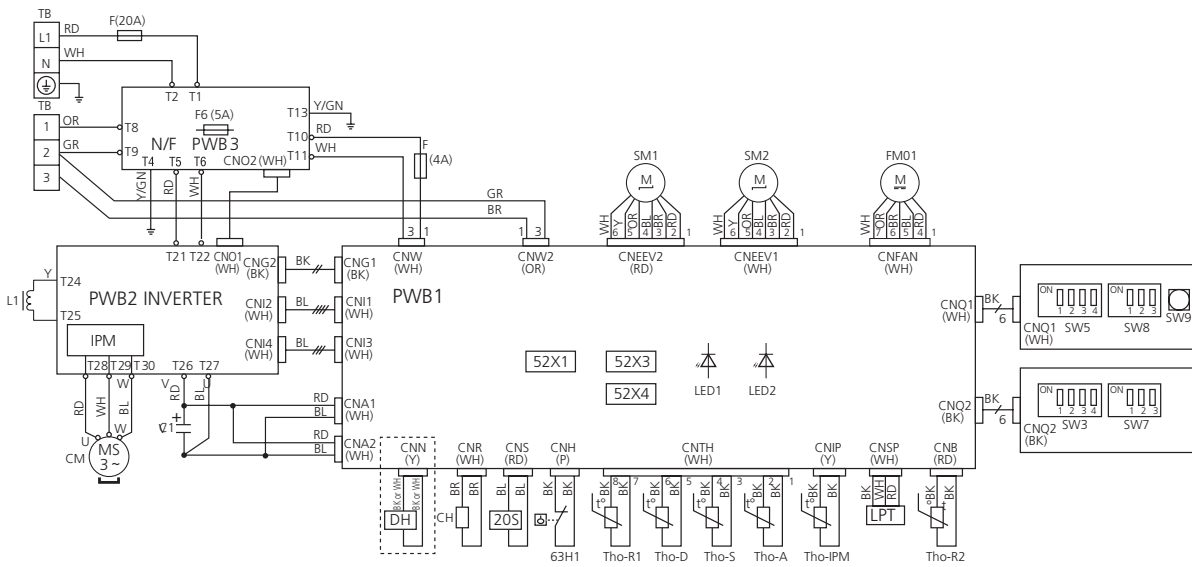

METROAIR L12

230V ~ 50Hz

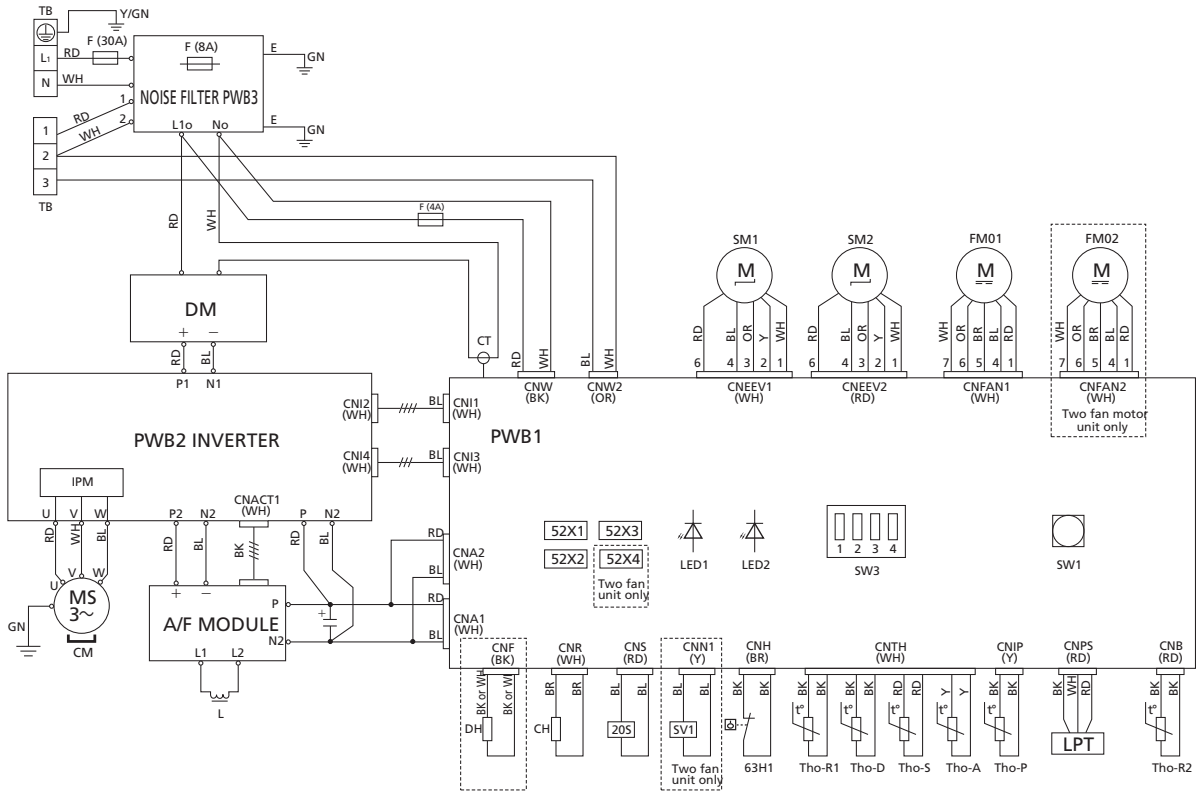

<i>Designation</i>	<i>Description</i>
20S	Solenoid for 4-way valve
52X1	Auxiliary relay (for CH)
52X2	Auxiliary relay (for DH)
52X3	Auxiliary relay (for 20S)
52X4	Auxiliary relay (for SV1)
63H1	High pressure pressostat
C1	Capacitor
CH	Compressor heater
CM	Compressor motor
CnA~Z	Terminal block
CT	Current sensor
DH	Drain pan heater
DM	Diode module
F	Fuse
FM01, FM02	Fan motor
IPM	Intelligent power module
L/L1	Induction coil
LED1	Indication lamp (red)
LED2	Indication lamp (green)
LPT	Low pressure transmitter
QN1 (EEV-H)	Expansion valve for heating
QN3 (EEV-C)	Expansion valve for cooling
SW1, 9	Pumpdown
SW3, 5, 7, 8	Local settings
TB	Terminal block
BT28 (Tho-A)	Temperature sensor, outdoor air
Tho-D	Temperature sensor, hot gas
Tho-R1	Temperature sensor, heat exchanger out
Tho-R2	Temperature sensor, heat exchanger, in
Tho-S	Temperature sensor, suction gas
Tho-P	Temperature sensor, IPM

Item register

A

Accessibility, electrical connection, 27
Accessories, 37
Alarm list, 34
Assembly, 9

C

Checklist: Checks before commissioning, 7
Commissioning and adjusting, 31
 Compressor heater, 31
Communication connection, 30
Component location, electrical panel, 20
Component location METROAIR L, 15
Compressor heater, 31
Connecting accessories, 30
Connections, 28
Control - Heat pump EB101, 32
Control modules, 8

D

Delivery and handling, 9
 Assembly, 9
 Installation area, 12
 Removing the covers, 13
 Transport and storage, 9
Dimensions, 38
Disturbances in comfort, 33

E

Electrical circuit diagram, 55
Electrical components, 27
Electrical connections, 26
 Accessibility, electrical connection, 27
 Communication connection, 30
 Connecting accessories, 30
 Connections, 28
 Electrical components, 27
 General, 26
 Power connection, 28
Energy labelling, 50
 Data for energy efficiency of the package, 50
 Information sheet, 50
 Technical documentation, 51
Energy rating, average climate, 45
Environmental information, 6

G

General, 26

I

Important information, 4
 Checklist: Checks before commissioning, 7
 Control modules, 8
 Environmental information, 6
 Indoor modules, 8
 Marking, 4
 Recovery, 6
 Safety information, 4
 Safety precautions, 4
 Serial number, 6
 Symbols, 4
 System solution, 4
Indoor modules, 8
Installation area, 12

L

List of components METROAIR L (EZ101), 19

M

Marking, 4

P

Pipe connections, 25
Power connection, 28

R

Recovery, 6
Removing the covers, 13

S

Safety information, 4
 Marking, 4
Symbols on METROAIR L, 4
Safety precautions, 4
Sensor placement, 22
Serial number, 6
Sound pressure levels, 42
Symbols, 4
Symbols on METROAIR L, 4
System solution, 4

T

Technical data, 38
 Dimensions, 38
 Electrical circuit diagram, 55
 Energy labelling, 50
 Energy rating, average climate, 45
 Sound pressure levels, 42

- Technical Data, 43
- Technical Data, 43
- The heat pump design, 15
 - Component location METROAIR L, 15
 - Component position electrical panel, 20
 - Electrical components METROAIR L, 21
 - List of components METROAIR L(EZ101), 19
- Transport and storage, 9
- Troubleshooting
 - Sensor placement, 22



METRO THERM A/S
RUNDINSVEJ 55
DK3200 HELSINGE
INFO@METROTHERM.DK
WWW.METROTHERM.DK