

Ground source heat pump NIBE F1226

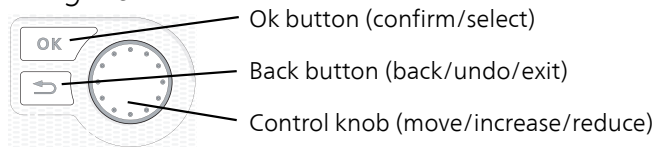

Quick guide

Navigation



A detailed explanation of the button functions can be found on page 32.

How to scroll through menus and make different settings is described on page 34.

Set the indoor climate

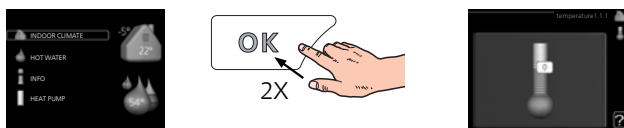

The mode for setting the indoor temperature is accessed by pressing the OK button twice, when in the start mode in the main menu.

Increase hot water volume



To temporarily increase the amount of hot water, first turn the control knob to mark menu 2 (water droplet) and then press the OK button twice.

Table of Contents

1	<i>Important information</i>	4	Start-up and inspection	28
	Safety information	4	Setting the heating curve	30
	Symbols	4		
	Marking	4	7 <i>Control - Introduction</i>	32
	Serial number	5	Display unit	32
	Recovery	5	Menu system	33
	Environmental information	5	8 <i>Control - Menus</i>	36
	Inspection of the installation	6	Menu 1 - INDOOR CLIMATE	36
2	<i>Delivery and handling</i>	7	Menu 2 - HOT WATER	36
	Transport	7	Menu 3 - INFO	36
	Assembly	7	Menu 4 - HEAT PUMP	37
	Supplied components	8	Menu 5 - SERVICE	38
	Removing the covers	8	9 <i>Service</i>	42
	Removing parts of the insulation	9	Service actions	42
3	<i>The heat pump design</i>	10	10 <i>Disturbances in comfort</i>	48
	General	10	Manage alarm	48
	Distribution boxes	12	Troubleshooting	48
	Cooling section (EP14)	13	11 <i>Accessories</i>	51
4	<i>Pipe connections</i>	15	12 <i>Technical data</i>	52
	General	15	Dimensions and setting-out coordinates	52
	Dimensions and pipe connections	16	Electrical data	53
	Brine side	17	Technical specifications	54
	Heating medium side	17	Energy labelling	56
	Cold and hot water	18	Electrical circuit diagram	60
	Docking alternatives	18	<i>Item register</i>	65
5	<i>Electrical connections</i>	20	<i>Contact information</i>	71
	General	20		
	Connections	22		
	Settings	23		
	Optional connections	25		
	Connecting accessories	26		
6	<i>Commissioning and adjusting</i>	27		
	Preparations	27		
	Filling and venting	27		

1 Important information

Safety information

This manual describes installation and service procedures for implementation by specialists.

The manual must be left with the customer.

This appliance can be used by children aged from 8 years and above and persons with reduced physical, sensory or mental capabilities or lack of experience and knowledge if they have been given supervision or instruction concerning use of the appliance in a safe way and understand the hazards involved. Children shall not play with the appliance. Cleaning and user maintenance shall not be made by children without supervision.

Rights to make any design or technical modifications are reserved.

©NIBE 2020.

Water may drip from the safety valve's overflow pipe. The entire length of the overflow water pipe must be routed to a suitable drain and be inclined to prevent water pockets, and must also be frost-proof. The overflow pipe must be at least the same size as the safety valve. The overflow pipe must be visible and its mouth must be open and not located close to electrical components.

F1226 must be installed via an isolator switch. The cable area has to be dimensioned based on the fuse rating used.

Symbols



NOTE

This symbol indicates danger to person or machine .



Caution

This symbol indicates important information about what you should consider when installing or servicing the installation.



TIP

This symbol indicates tips on how to facilitate using the product.

Marking

CE The CE mark is obligatory for most products sold in the EU, regardless of where they are made.

IPX1B Classification of enclosure of electro-technical equipment.



Danger to person or machine.



Read the User Manual.

Serial number

The serial number can be found at the bottom right of the front cover, in the info menu (menu 3.1) and on the type plate (PZ1).

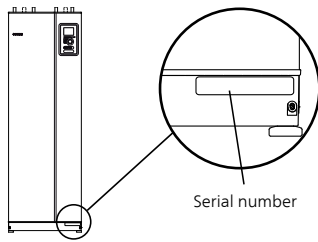

Caution

You need the product's ((14 digit) serial number for servicing and support.

Recovery



Leave the disposal of the packaging to the installer who installed the product or to special waste stations.

Do not dispose of used products with normal household waste. It must be disposed of at a special waste station or dealer who provides this type of service.

Improper disposal of the product by the user results in administrative penalties in accordance with current legislation.

Environmental information

F-GAS REGULATION (EU) NO. 517/2014

This unit contains a fluorinated greenhouse gas that is covered by the Kyoto agreement.

The equipment contains R407C, a fluorinated greenhouse gas with a GWP value (Global Warming Potential) of 1,774. Do not release R407C into the atmosphere.

Inspection of the installation

Current regulations require the heating installation to be inspected before it is commissioned. The inspection must be carried out by a suitably qualified person.

In addition, fill in the page for the installation data in the User Manual.

✓	Description	Notes	Signature	Date
	Brine (page 17)			
	System flushed			
	System vented			
	Antifreeze			
	Level/Expansion vessel			
	Particle filter			
	Safety valve			
	Shut off valves			
	Circulation pump setting			
	Heating medium (page 17)			
	System flushed			
	System vented			
	Expansion vessel			
	Particle filter			
	Safety valve			
	Shut off valves			
	Circulation pump setting			
	Electricity (page 20)			
	Connections			
	Main voltage			
	Phase voltage			
	Fuses heat pump			
	Fuses property			
	Outside sensor			
	Safety breaker			
	Earth circuit-breaker			
	Setting of emergency mode thermostat			

2 Delivery and handling

Transport

F1226 should be transported and stored vertically in a dry place. When being moved into a building, F1226 may be leant back 45°.

Ensure that F1226 has not been damaged during transport.



Caution

The product can be tail heavy.

Remove the outer panels in order to protect them when moving in confined spaces inside buildings.

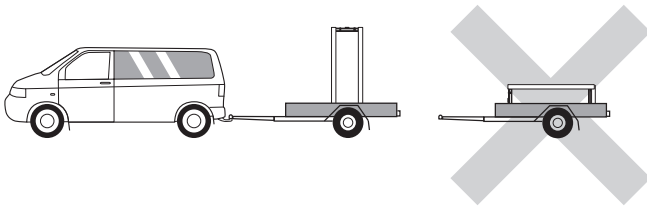

EXTRACTING THE COOLING MODULE

To simplify transport and service, the heat pump can be separated by pulling the cooling module out from the cabinet.

See page 44 for instructions about the separation.

Assembly

- Place F1226 on a solid foundation indoors that can take the heat pump's weight. Use the product's adjustable feet to obtain a horizontal and stable set-up.

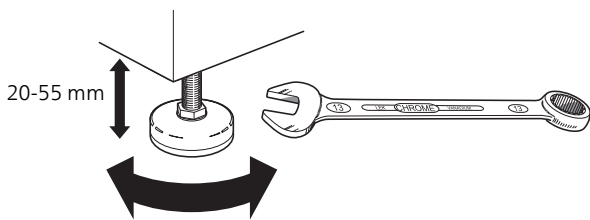

- Because water comes from F1226, the area where the heating pump is located must be equipped with floor drainage.

- Install with its back to an outside wall, ideally in a room where noise does not matter, in order to eliminate noise problems. If this is not possible, avoid placing it against a wall behind a bedroom or other room where noise may be a problem.

- Wherever the unit is located, walls to sound sensitive rooms should be fitted with sound insulation.

- Route pipes so they are not fixed to an internal wall that backs on to a bedroom or living room.

INSTALLATION AREA

Leave a free space of 800 mm in front of the product. Approx. 50 mm free space is required on each side, to remove the side panels (see image). The panels do not need to be removed during service. All service on F1226 can be carried out from the front. Leave space between the heat pump and the wall behind (and any routing of supply cables and pipes) to reduce the risk of any vibration being propagated.

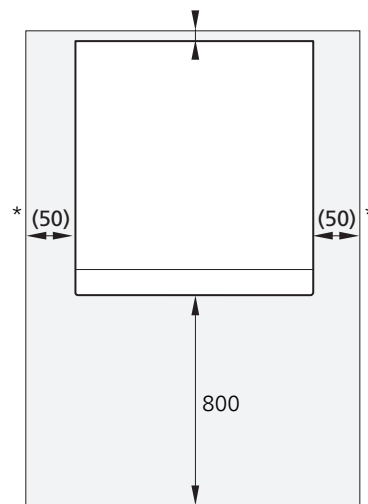

* A normal installation needs 300 – 400 mm (any side) for connection equipment, valves and electrical equipment.

Supplied components Removing the covers



Outside sensor



Safety valve
0.3 MPa (3 bar)



O-rings

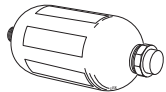

Level vessel



Particle filter

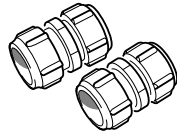

Compression ring
couplings

6-8 kW

2 x (ø28 x G25)

2 x (ø22 x G20)

12 kW

4 x (ø28 x G25)

LOCATION

The kit of supplied items is placed in packaging on top of the heat pump.

FRONT COVER

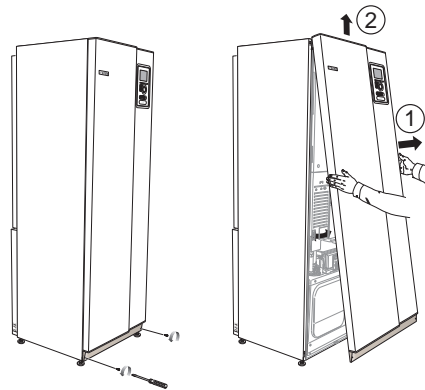

1. Remove the screws from the lower edge of the front panel.
2. Lift the panel out at the bottom edge and up.

SIDE COVERS

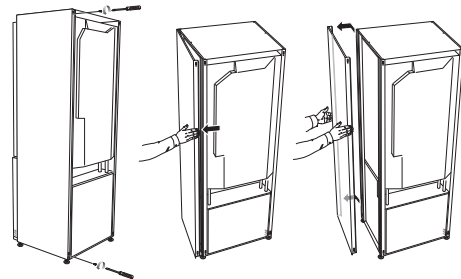

The side covers can be removed to facilitate the installation.

1. Remove the screws from the upper and lower edges.
2. Twist the cover slightly outward.
3. Move the hatch outwards and backwards.
4. Assembly takes place in the reverse order.

Removing parts of the insulation

Parts of the insulation can be removed to facilitate the installation.

INSULATION, TOP

1. Disconnect the cable from the motor and remove the motor from the shuttle valve as illustrated.

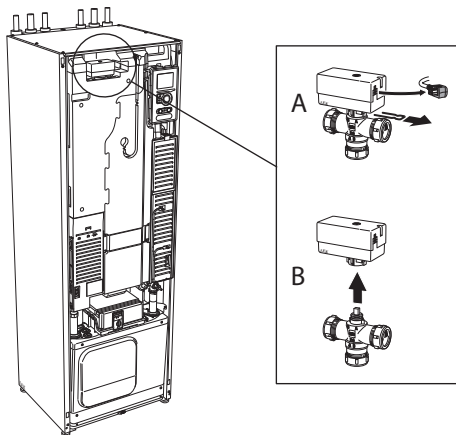

2. Grip the handle and pull straight out as illustrated.

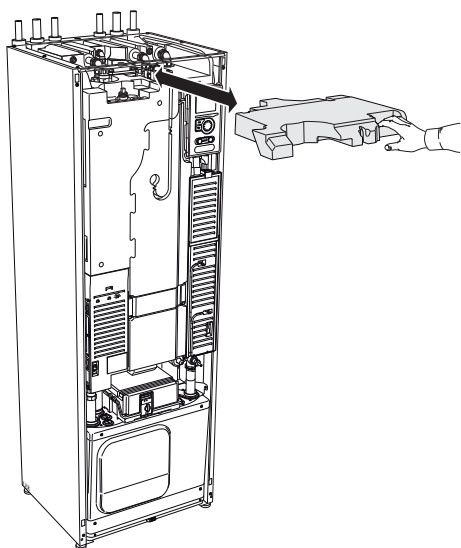

INSULATION, IMMERSION HEATER



NOTE

Electrical installation and service must be carried out under the supervision of a qualified electrician. Electrical installation and wiring must be carried out in accordance with the stipulations in force.

1. Remove the cover for the junction box according to the description on page 21.
2. Grip the handle and pull the insulation carefully towards you as illustrated.

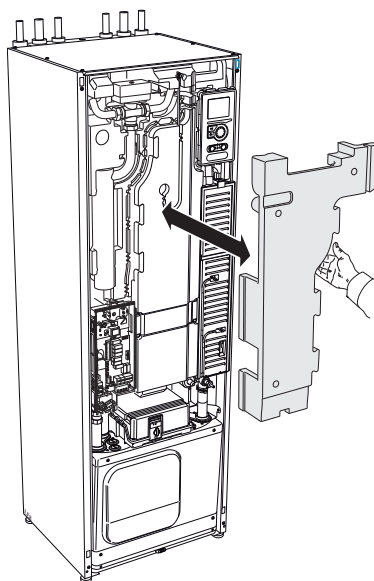

3 The heat pump design

General

VIEW FROM ABOVE

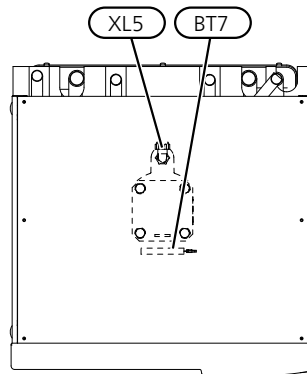
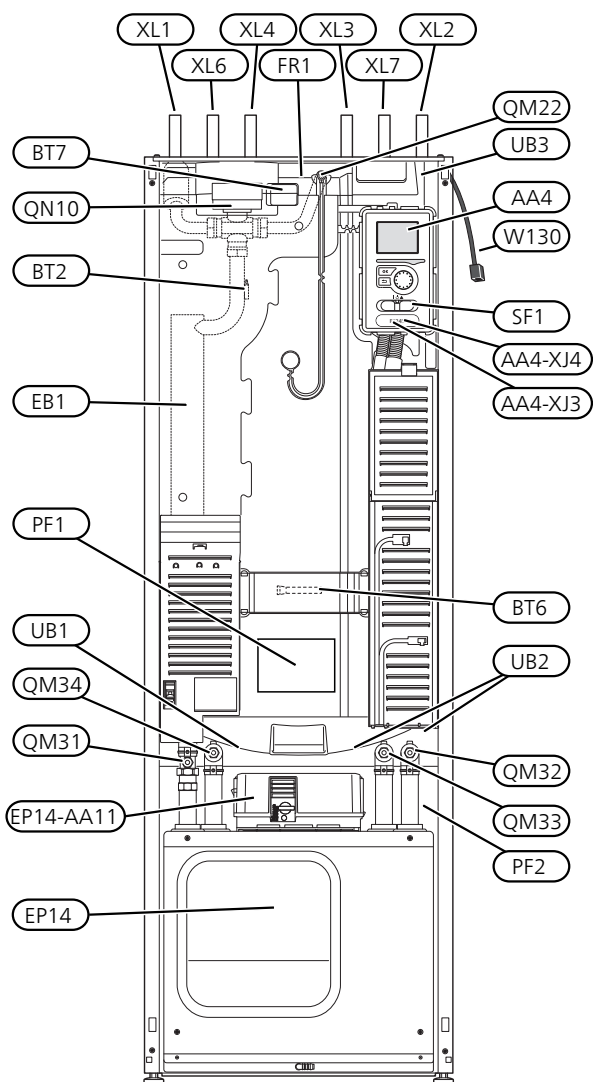

PIPE CONNECTIONS

XL1	Connection, heating medium flow
XL2	Connection, heating medium return
XL3	Connection, cold water
XL4	Connection, hot water
XL5	Connection, HWC*
XL6	Connection, brine in
XL7	Connection, brine out

* Only heat pumps with stainless steel vessel.

HVAC COMPONENTS

QM22	Venting, coil
QM31	Shut-off valve, heating medium flow
QM32	Shut off valve, heating medium return
QM33	Shut off valve, brine out
QM34	Shut-off valve, brine in
QN10	Shuttle valve, climate system/water heater

SENSORS ETC.

BT1	Outdoor temperature sensor*
BT2	Temperature sensors, heating medium flow
BT6	Temperature sensor, hot water charging
BT7	Temperature sensor, hot water top

* Not illustrated

ELECTRICAL COMPONENTS

AA4	Display unit
	AA4-XJ3 USB socket
	AA4-XJ4 Service outlet (No function)
AA11	Motor module
EB1	Immersion heater
SF1	Switch

MISCELLANEOUS

EP14	Cooling section
PF1	Rating plate
PF2	Type plate, cooling section
UB1	Cable gland, incoming electricity
UB2	Cable gland
UB3	Cable gland, rear side, sensor

Designations according to standard EN 81346-2.

Distribution boxes

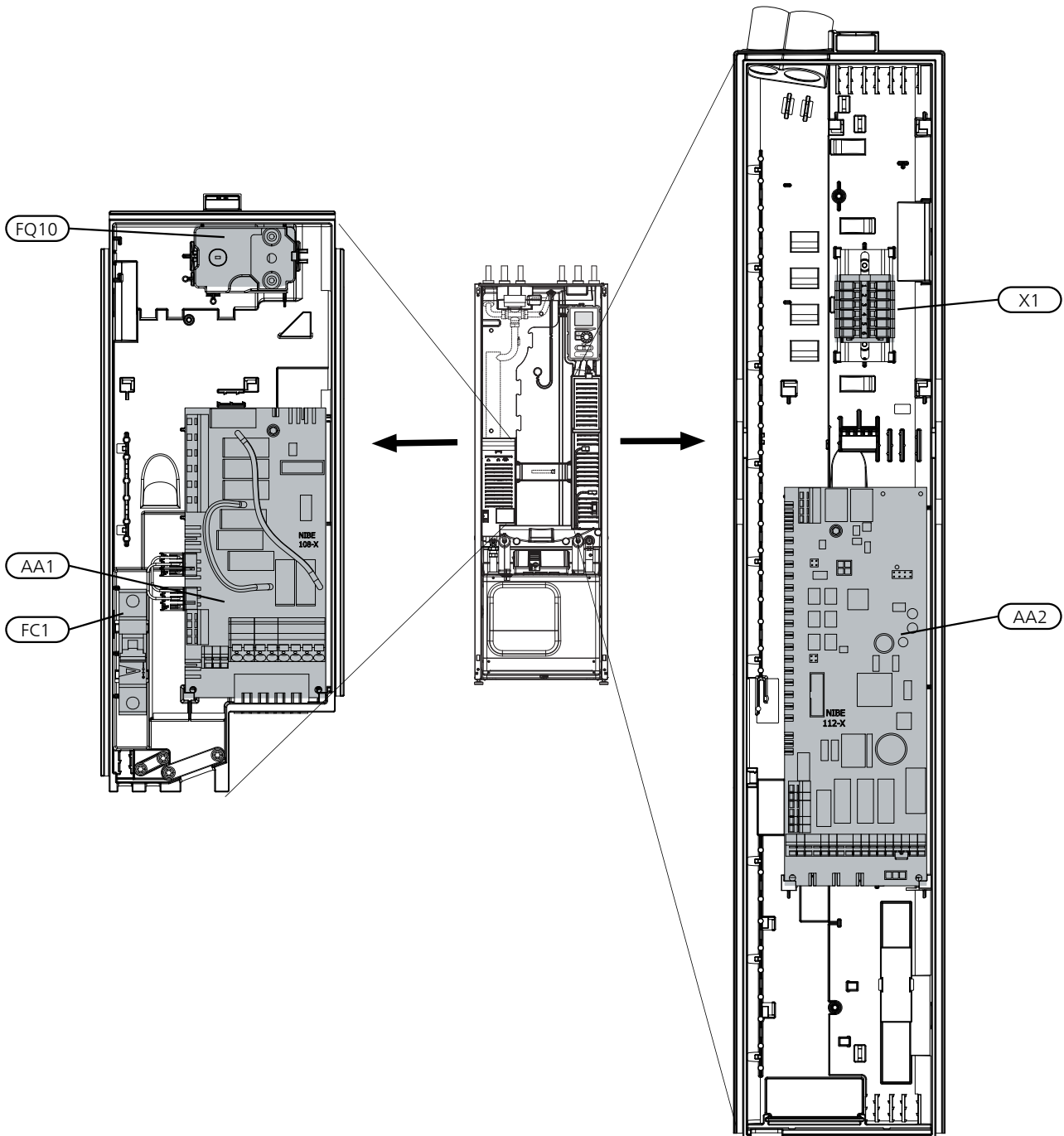

ELECTRICAL COMPONENTS

- AA1 Immersion heater card
- AA2 Base card
- FC1 Miniature circuit-breaker
- FQ10 Temperature limiter/Emergency mode thermostat
- X1 Terminal block

MOTOR MODULE (AA11)

3x400 V 6-8 kW

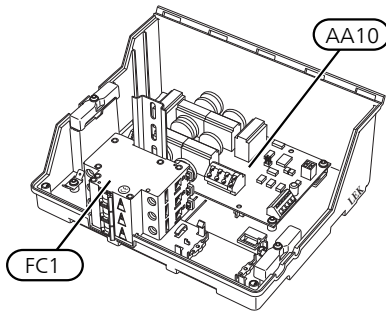

3x400V 12 kW

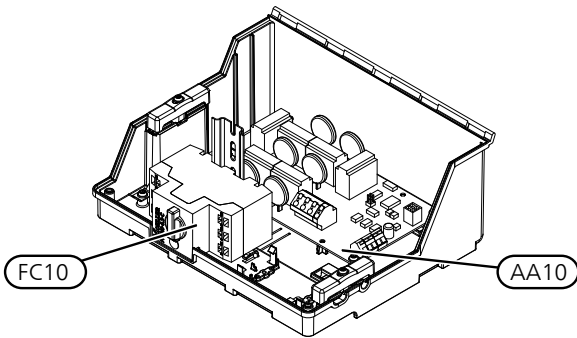

ELECTRICAL COMPONENTS

AA10 Soft-start card

FC1 Miniature circuit-breaker

FC10 Motor cut-out

Cooling section (EP14)

6 & 8 kW

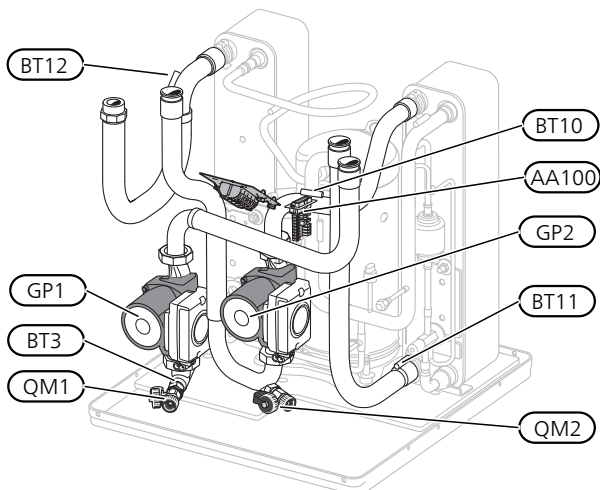

12 kW

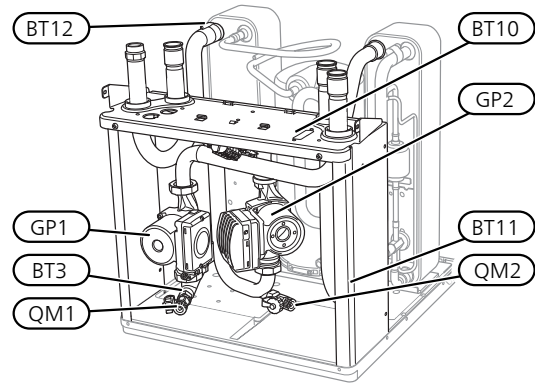

6 & 8 kW

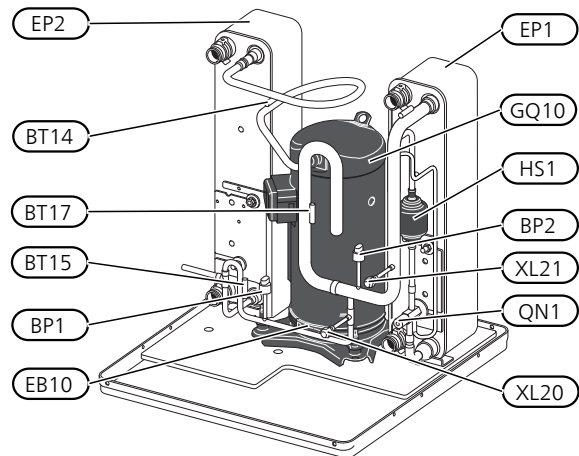

12 kW

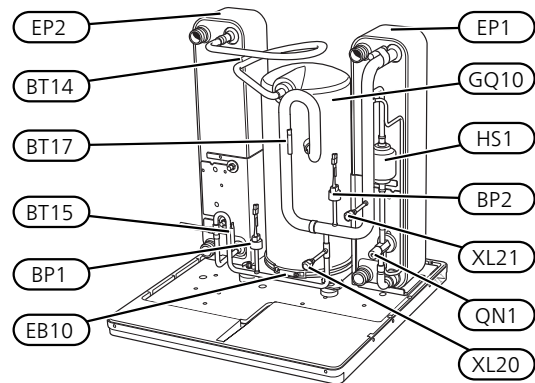

PIPE CONNECTIONS

XL20 Service connection, high pressure

XL21 Service connection, low pressure

HVAC COMPONENTS

GP1 Circulation pump

GP2 Brine pump

QM1 Drainage, climate system

QM2 Draining, brine side

SENSORS ETC.

BP1	High pressure pressostat
BP2	Low pressure pressostat
BT3	Temperature sensors, heating medium return
BT10	Temperature sensor, brine in
BT11	Temperature sensor, brine out
BT12	Temperature sensor, condenser supply line
BT14	Temperature sensor, hot gas
BT15	Temperature sensor, fluid pipe
BT17	Temperature sensor, suction gas

ELECTRICAL COMPONENTS

AA100	Joint card
EB10	Compressor heater

COOLING COMPONENTS

EP1	Evaporator
EP2	Condenser
GQ10	Compressor
HS1	Drying filter
QN1	Expansion valve

4 Pipe connections

General

Pipe installation must be carried out in accordance with current norms and directives. F1226 can operate with a return temperature of up to 56 °C and an outgoing temperature from the heat pump of 70 (63 °C with only the compressor).

F1226 is not equipped with external shut off valves; these must be installed to facilitate any future servicing.



Caution

Ensure that incoming water is clean. When using a private well, it may be necessary to supplement with an extra water filter.



Caution

Any high points in the climate system, must be equipped with air vents.



NOTE

The pipe systems need to be flushed out before the heat pump is connected so debris cannot damage component parts.



NOTE

Water may drip from the safety valve's overflow pipe. The entire length of the overflow water pipe must be routed to a suitable drain and be inclined to prevent water pockets, and must also be frost-proof. The overflow pipe must be at least the same size as the safety valve. The overflow pipe must be visible and its mouth must be open and not located close to electrical components.

SYMBOL KEY

Symbol	Meaning
	Venting valve
	Shut-off valve
	Non-return valve
	Circulation pump
	Expansion vessel
	Auxiliary relay
	Compressor
	Pressure gauge
	Level vessel
	Particle filter
	Safety valve
	Temperature sensor
	Trim valve
	Reversing valve/shunt
	Heat exchanger

SYSTEM DIAGRAM

F1226 consists of a heat pump, water heater, electrical module, circulation pumps and a control system. F1226 is connected to the brine and heating medium circuits.

In the heat pump evaporator, the brine (water mixed with anti-freeze, glycol or ethanol) releases its energy to the refrigerant, which is vaporised in order to be compressed in the compressor. The refrigerant, of which the temperature has now been raised, is passed to the condenser where it gives off its energy to the heating medium circuit and, if necessary, to the water heater. If there is a greater need for heating/hot water than the compressor can provide there is an integrated immersion heater.

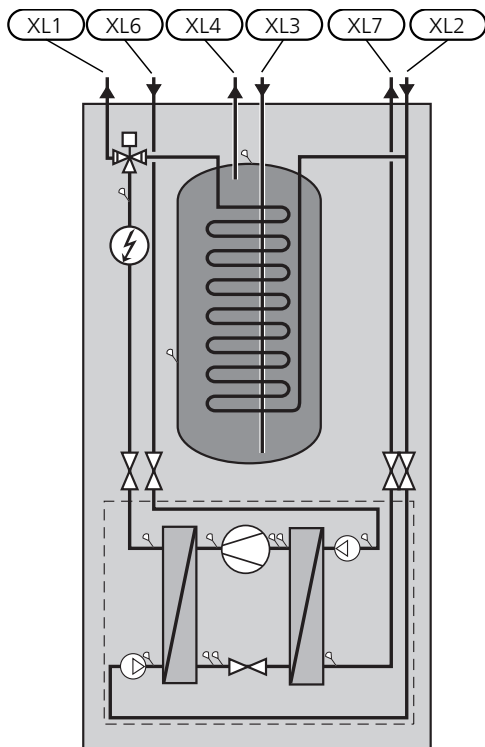

- XL1 Connection, heating medium flow
- XL2 Connection, heating medium return
- XL3 Connection, cold water
- XL4 Connection, hot water
- XL6 Connection, brine in
- XL7 Connection, brine out

Dimensions and pipe connections

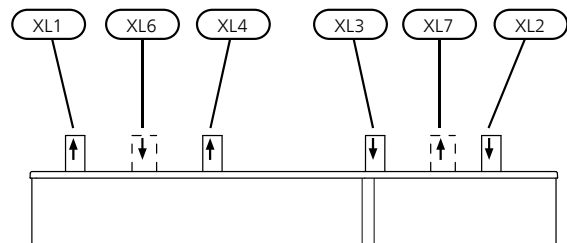
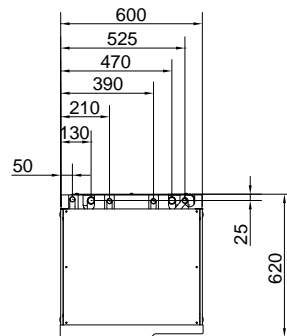
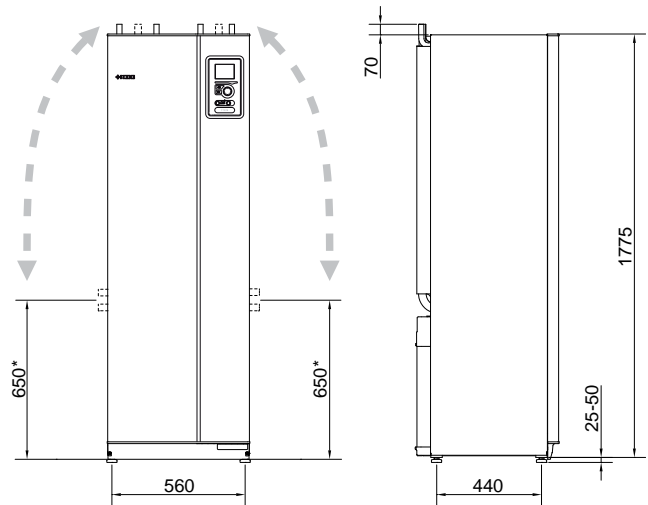

PIPE DIMENSIONS

Connection	(kW)	6-8	12
(XL6)/(XL7) Brine in/out ext Ø	(mm)	28	
(XL1)/(XL2) Heating medium flow/return ext Ø	(mm)	22	28
(XL3)/(XL4) Cold/hot water Ø	(mm)	22	

* Can be angled for side connection.

Brine side

COLLECTOR



Caution

The length of the collector hose varies depending on the rock/soil conditions, climate zone and on the climate system (radiators or under-floor heating) and the heating requirement of the building. Each installation must be sized individually.

Max. length per coil for the collector should not exceed 400 m.

In those cases where it is necessary to have several collectors, these should be connected in parallel with the possibility for adjusting the flow of the relevant coil.

For surface soil heat, the hose should be buried at a depth determined by local conditions and the distance between the hoses should be at least 1 metre.

For several bore holes, the distance between the holes must be determined according to local conditions.

Ensure the collector hose rises constantly towards the heat pump to avoid air pockets. If this is not possible, airvents should be used.

Because the temperature of the brine system can fall below 0 °C, it must be protected against freezing down to -15 °C. When making the volume calculation, use 1 litre of ready mixed brine per metre of collector hose (applies when using PEM-hose 40x2.4 PN 6.3) as a guide value.

SIDE CONNECTION

It is possible to angle the brine connections, for connection to the side instead of top connection.

To angle out a connection:

1. Disconnect the pipe at the top connection.
2. Angle the pipe in the desired direction.
3. If necessary, cut the pipe to the desired length.

CONNECTING THE BRINE SIDE

- Insulate all indoor brine pipes against condensation.
- The level vessel must be installed as the highest point in the brine system on the incoming pipe before the brine pump (Alt. 1).

If the level vessel cannot be placed at the highest point, an expansion vessel must be used (Alt. 2).



NOTE

Note that condensation may drip from the level vessel. Position the vessel so that this does not harm other equipment.

- Details of the antifreeze used must be shown on the level vessel.
- Install the enclosed safety valve below the level vessel as illustrated.
- Install shut off valves as close to the heat pump as possible.
- Fit the enclosed particle filter on the incoming brine.



TIP

If filling connection KB25/KB32 is used, the enclosed filterball does not need to be fitted.

In the case of connection to an open groundwater system, an intermediate frost-protected circuit must be provided, because of the risk of dirt and freezing in the evaporator. This requires an extra heat exchanger.

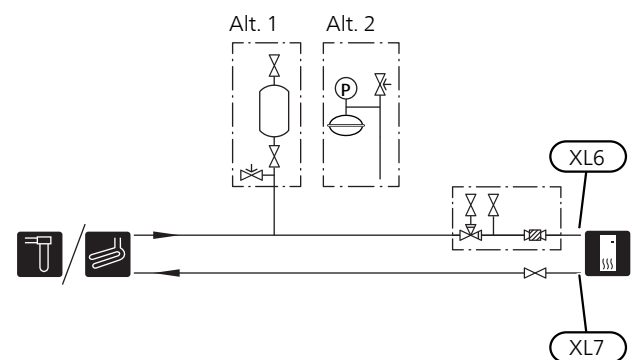

Heating medium side

CONNECTING THE CLIMATE SYSTEM

A climate system is a system that regulates indoor comfort with the help of the control system in F1226 and for example radiators, underfloor heating/cooling, fan convectors etc.

- Install all required safety devices, shut-off valves (as close to the heat pump as possible), and supplied particle filter.

- Fit safety valve on heating medium return as illustrated. Recommended opening pressure is 0.25 MPa (2.5 bar). For information about max opening pressure, see technical specifications.
- When connecting to a system with thermostats on all radiators (or underfloor heating coils), either a bypass valve must be fitted or some of the thermostats must be removed to ensure there is sufficient flow.

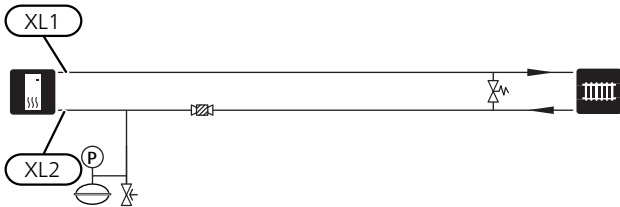

Cold and hot water

CONNECTING COLD AND HOT WATER

- Fit shut-off valve, non-return valve and safety valve as illustrated.
- The safety valve must have a maximum 1.0 MPa (10.0 bar) opening pressure and be installed on the incoming domestic water line as shown.
- A mixer valve must also be installed, if the factory setting for hot water is changed. National regulations must be observed.
- The setting for hot water is made in menu 5.1.1 (page 38).

!harBackventil

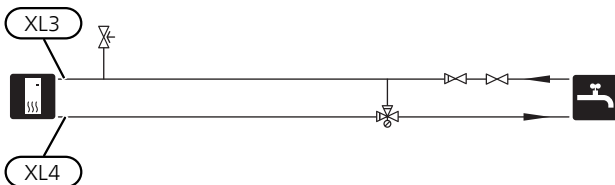

Docking alternatives

F1226 can be connected in several different ways, some of which are shown below.

Further option information is available at nibe.eu and in the respective assembly instructions for the accessories used. See page 51 for a list of the accessories that can be used with F1226.

BUFFER VESSEL

If the climate system volume is too small for the heat pump output, the radiator system can be supplemented with a buffer vessel, for example NIBE UKV.

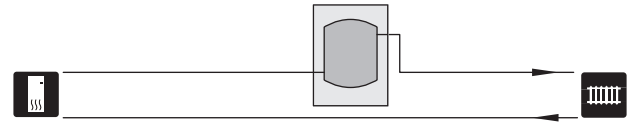

EXTRA HOT WATER HEATERS

The system should be supplemented with an extra water heater, if a large bath tub or other significant consumer of hot water is installed.

Water heater with immersion heater

If it is possible to use a water heater with an immersion heater, connect it as illustrated below.

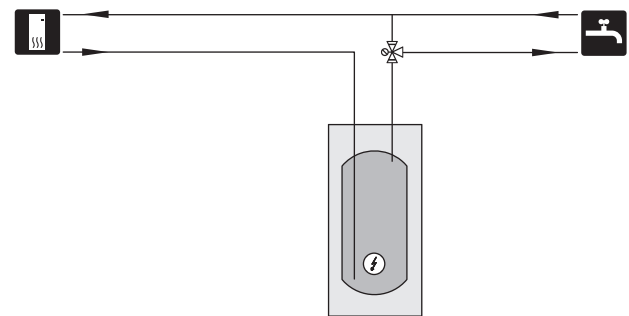

GROUND WATER SYSTEM

An intermediate heat exchanger is used to protect the heat pump's exchanger from dirt. The water is released into a buried filtration unit or a drilled well. This docking alternative requires the EXC 40 accessory.

If this docking alternative is used, "min. brine out" in menu 5.1.7 "br pmp al set." must be changed to a suitable value to prevent freezing of the heat exchanger.

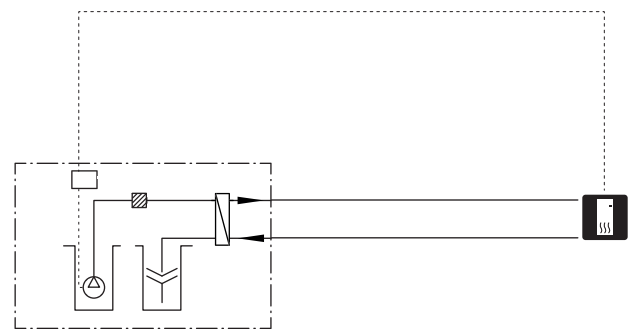

VENTILATION RECOVERY

The installation can be supplemented with the exhaust air module NIBE FLM to provide ventilation recovery.

- Pipes and other cold surfaces must be insulated with diffusion-proof material to prevent condensation.
- The brine system must be supplied with a pressure expansion vessel. If there is a level vessel this should be replaced.

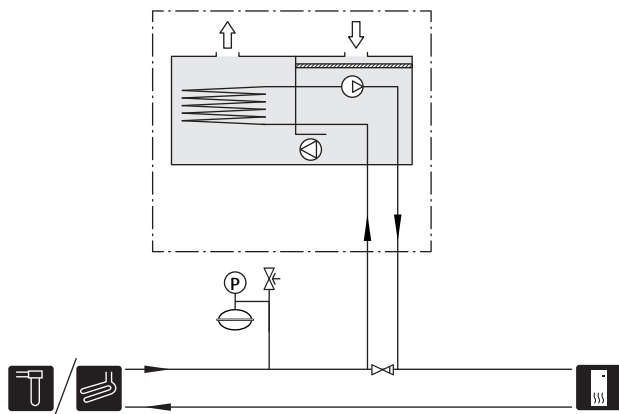

FREE COOLING

The installation can be supplemented with fan convectors, for example, in order to allow connections for free cooling.

- Pipes and other cold surfaces must be insulated with diffusion-proof material to prevent condensation.
- Where the cooling demand is high, fan convectors with drip trays and drain connection are needed.
- The brine system must be supplied with a pressure expansion vessel. If there is a level vessel this should be replaced.

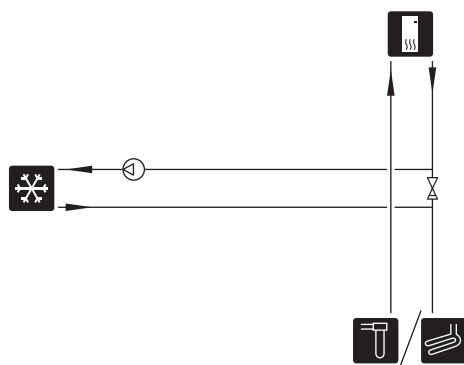

UNDERFLOOR HEATING SYSTEM

The external circulation pump is dimensioned for the under floor heating system's demand.

If the climate system volume is too small for the heat pump output, the underfloor heating system can be supplemented with a buffer vessel, for example NIBE UKV.

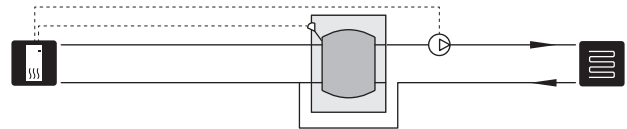

5 Electrical connections

General

All electrical equipment except for the outdoor temperature sensors has been connected at the factory.

- Disconnect the heat pump before insulation testing the house wiring.
- If the building is equipped with an earth-fault breaker, F1226 should be equipped with a separate one.
- If a miniature circuit breaker is used this should have at least motor characteristic "C". See page 53 for fuse size.
- Electrical wiring diagram for the heat pump, see page 60.
- Communication and sensor cables to external connections must not be laid close to high current cables.
- The minimum area of communication and sensor cables to external connections must be 0.5 mm² up to 50 m, for example EKKX or LiYY or equivalent.
- When cable routing in F1226, cable grommets (e.g. UB1-UB3, marked in image) must be used. In UB1-UB3 the cables are inserted through the heat pump from the back to the front.



NOTE

The switch (SF1) must not be moved to "I" or "⚠" until the boiler has been filled with water. Components in the product could be damaged.



NOTE

Electrical installation and service must be carried out under the supervision of a qualified electrician. Cut the current with the circuit breaker before carrying out any servicing. Electrical installation and wiring must be carried out in accordance with the stipulations in force.



NOTE

Check the connections, main voltage and phase voltage before the machine is started, to prevent damage to the heat pump electronics.

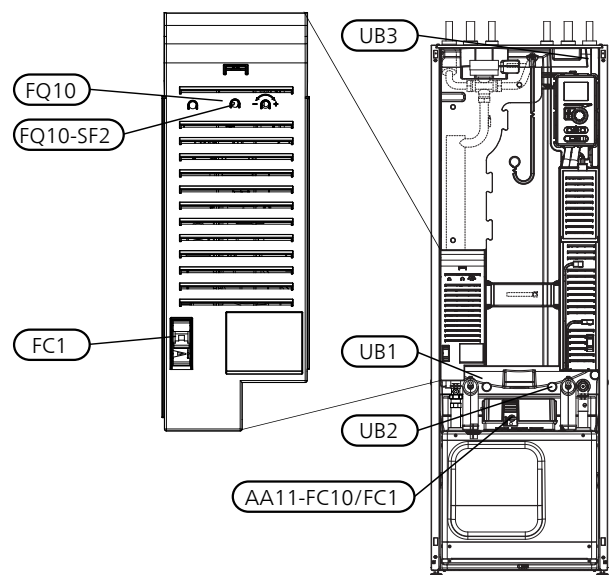

MINIATURE CIRCUIT-BREAKER

The heat pump operating circuit and some of its internal components are internally fused by a miniature circuit breaker (FC1).

TEMPERATURE LIMITER

The temperature limiter (FQ10) cuts the power to the electric additional heat if the temperature exceeds 89°C and is reset manually.

Resetting

The temperature limiter (FQ10) is accessed behind the front cover. Reset the temperature limiter by pressing the button (FQ10-SF2) using a small screwdriver.

MOTOR PROTECTION BREAKER /MINIATURE CIRCUIT BREAKER

Motor protection breaker (AA11-FC10) / miniature circuit breaker (AA11-FC1) cuts the power to the compressor if the current is too high. It is located behind the front cover and is reset manually.



Caution

Check the miniature circuit-breaker, temperature limiter and motor protection breaker. They may have tripped during transportation.

ACCESSIBILITY, ELECTRICAL CONNECTION

The plastic cap of the electrical boxes is opened using a screwdriver.



NOTE

The cover for the terminal block for soft inputs is opened without a tool.

Removing the cover, terminal block

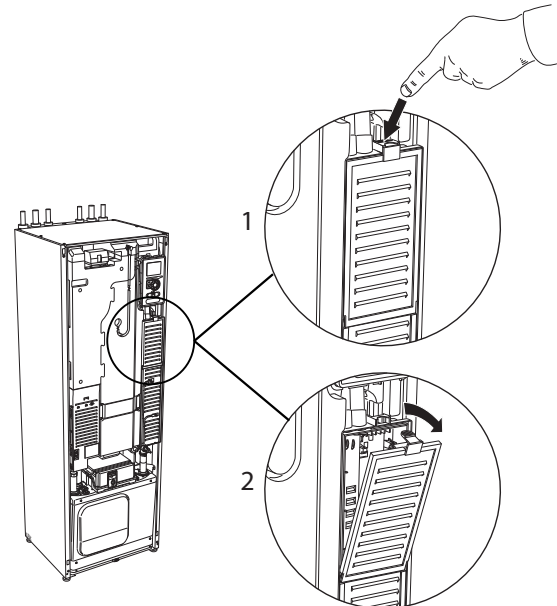

1. Push the catch down.
2. Angle out the cover and remove it.

Removing the cover, immersion heater circuit board

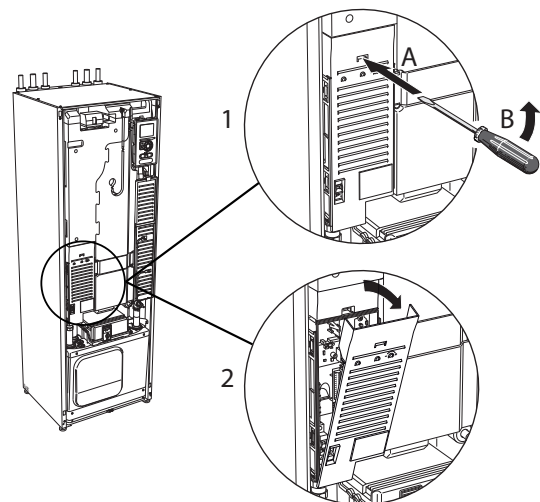

1. Insert the screwdriver (A) and pry the catch carefully downwards (B).
2. Angle out the cover and remove it.

Removing the cover, base board



Caution

To remove the cover for the base board, the cover for the terminal block for soft inputs must first be removed.

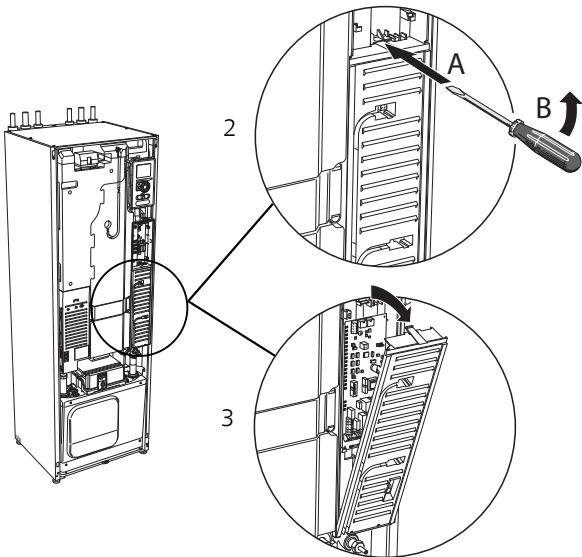
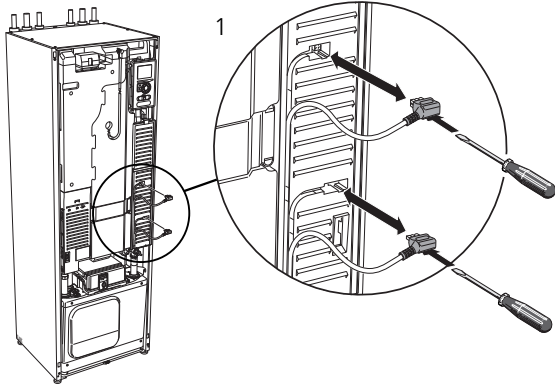

1. Disconnect the switches using a screwdriver.
2. Insert the screwdriver (A) and pry the catch carefully downwards (B).
3. Angle out the cover and remove it.

CABLE LOCK

Use a suitable tool to release/lock cables in the heat pump terminal blocks.

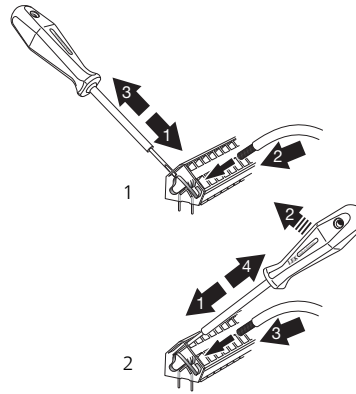

Connections



NOTE

To prevent interference, unshielded communication and/or sensor to external connections cables must not be laid closer than 20 cm to high voltage cable when cable routing.

POWER CONNECTION

F1226 must be installed with a disconnection option on the supply cable. Minimum cable area must be sized according to the fuse rating used. Enclosed cable for incoming supply electricity is connected to terminal block X1 on the immersion heater board (AA1). All installations must be carried out in accordance with current norms and directives.

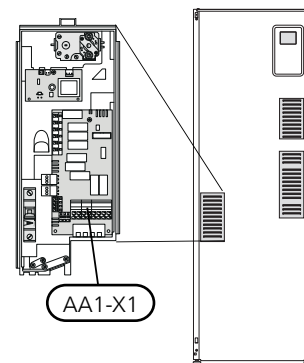

Connection 3x400V

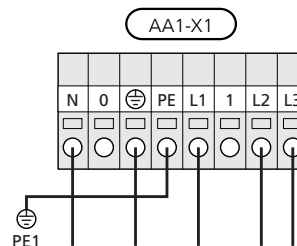



NOTE

F1226 contains scroll compressor, which means that it is important that electrical connections are made with the correct phase sequence. With the incorrect phase sequence, the compressor does not start and an alarm is displayed.

If a separate supply to the compressor and electric heater is wanted, see section "External blocking of functions" on page 26.

TARIFF CONTROL

If the voltage to the immersion heater and/or the compressor disappears during a certain period, there must also be blocking via the AUX-input, see "Connection options - Possible selection for AUX inputs" page. 26

CONNECTING EXTERNAL OPERATING VOLTAGE FOR THE CONTROL SYSTEM



NOTE

Mark up any junction boxes with warnings for external voltage.

If you wish to connect external operating voltage for the control system to F1226 on the immersion heater circuit board (AA1) the edge connector at AA1:X2 must be moved to AA1:X9 (as illustrated).

Operating voltage (1x230V ~ 50Hz) is connected to AA1:X11 (as illustrated).

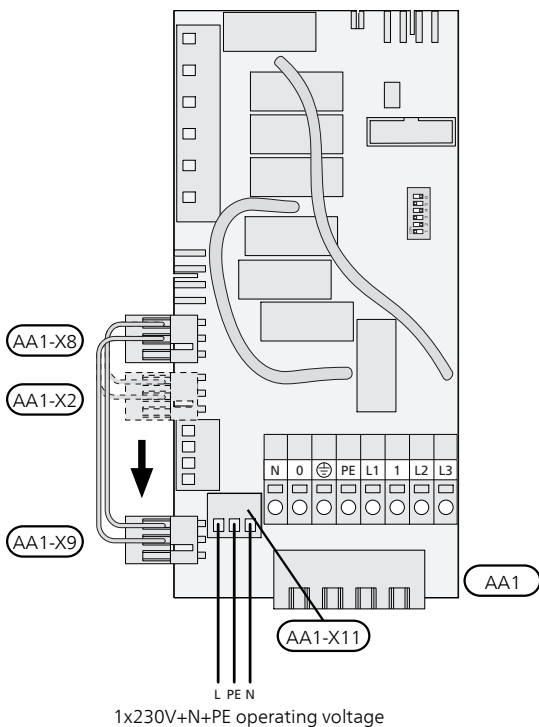

CONNECTING SENSORS

Connect the sensor(s) to terminal block X1 according to the instructions below.

Outside sensor

Install the outdoor temperature sensor (BT1) in the shade on a wall facing north or north-west, so it is unaffected by the morning sun for example.

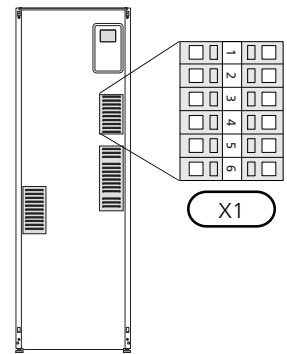

Connect the sensor to terminal block X1:1 and X1:2.

If a conduit is used it must be sealed to prevent condensation in the sensor capsule.

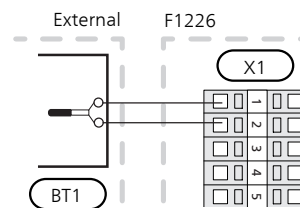

Settings

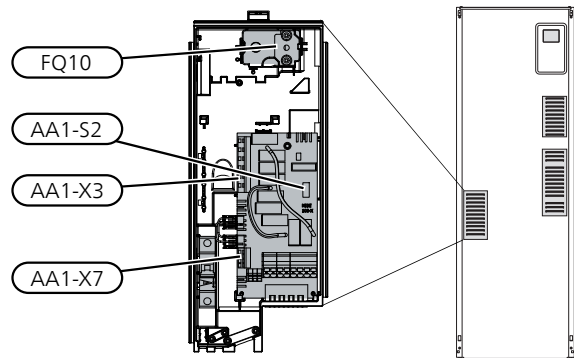

ELECTRICAL ADDITION - MAXIMUM OUTPUT

The electric additional heat may be restricted depending on the selected country.

On delivery, the immersion heater is connected for a maximum of 7 kW (switchable to 9 kW).

The immersion heater's output is split into seven steps (four steps if the immersion heater is switched to maximum 9 kW), according to the table below.

Setting max electrical output

Setting maximum output in the electric additional heat is done in menu 5.1.12.

The table displays the total phase current for the immersion heater at start up. If an immersion heater has already been started and is not used for its full capacity the values in the table can be changed because the control initially uses this immersion heater.

Switching to maximum electrical output

If more than the maximum output (7 kW) for the immersion heater connected on delivery is needed, the heat pump can be switched to maximum 9 kW.

Move the white cable from terminal block X7:23 to terminal block X3:13 (the seal on the terminal block must be broken) on the immersion heater card (AA1).

3x400V V (maximum electrical output, connected upon delivery 7 kW)

Max electrical addition (kW)	Max phase current L1(A)	Max phase current L2(A)	Max phase current L3(A)
0	–	–	–
1	–	–	4.3
2	–	8.7	–
3	–	8.7	4.3
4	–	8.7	8.7
5	–	8.7	13.0
6	8.7	8.7	8.7
7	8.7	8.7	13.0

3x400V (maximum electrical output, switched to 9 kW)

Max electrical addition (kW)	Max phase current L1(A)	Max phase current L2(A)	Max phase current L3(A)
0	–	–	–
2	–	8.7	–
4	–	8.7	8.7
6	8.7	8.7	8.7
9	8.7	15.6	15.6

EMERGENCY MODE

When the heat pump is set to emergency mode (SF1 is set to Δ) only the most necessary functions are activated.

- The compressor is off and heating is managed by the immersion heater.
- Hot water is not produced.



NOTE

The switch (SF1) must not be moved to "I" or " Δ " until F1226 has been filled with water. Components in the product can be damaged.

Power in emergency mode

The immersion heater's output in emergency mode is set with the dipswitch (S2) on the immersion heater circuit board (AA1) according to the table below. Factory setting is 6 kW.

When installing according to current building regulations (BBR) the immersion heater's power in emergency mode must be set to the maximum permitted electrical output.

3x400V (maximum electrical output, connected upon delivery 7 kW)

kW	1	2	3	4	5	6
1	off	off	off	off	off	on
2	off	off	on	off	off	off
3	off	off	on	off	off	on
4	off	off	on	off	on	off
5	on	off	on	off	off	on
6	on	off	on	off	on	off
7	on	off	on	off	on	on

3x400V (maximum electrical output, switched to 9 kW)

kW	1	2	3	4	5	6
2	off	off	off	off	on	off
4	off	off	on	off	on	off
6	on	off	on	off	on	off
9	on	off	on	on	on	on

3x400V

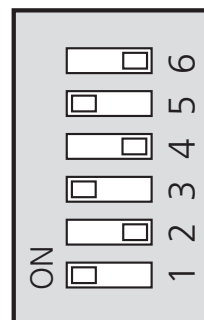

AA1-S2

The image shows the dip-switch (AA1-S2) in the factory setting.

Emergency mode thermostat

The supply temperature in emergency mode is set using a thermostat (FQ10). It can be set to 35 (pre-set, for example underfloor heating) or 45 °C (for example radiators).

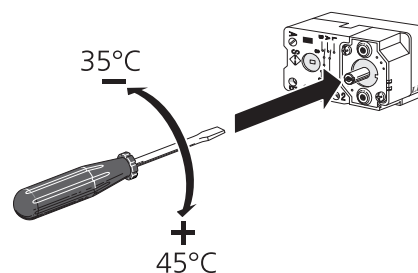

Optional connections

EXTERNAL CONNECTION OPTIONS

On the terminal block (X1), F1226 has software-controlled AUX inputs for connecting external switch function or sensor. This means that when an external switch function (the switch must be potential-free) or sensor is connected to one of two special connections, this function must be selected for the correct connection in menu 5.4.

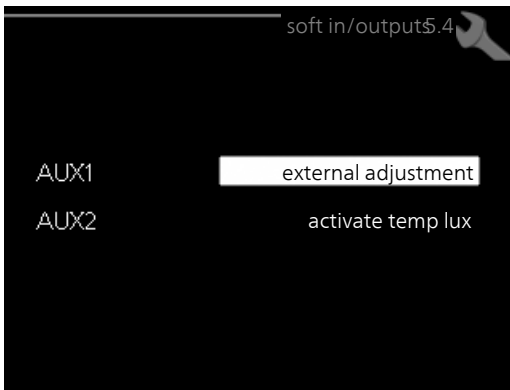

For certain functions, accessories may be required.

Selectable inputs

Selectable inputs on the input board for these functions are:

AUX1	X1:3-4
AUX2	X1:5-6

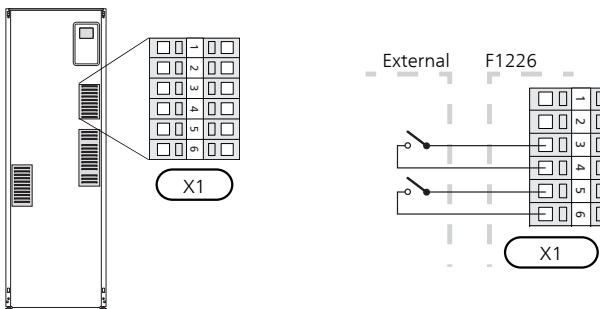

The example above uses the inputs AUX1 (X1:3-4) and AUX2 (X1:5-6) on terminal block (X1).



TIP

Some of the following functions can also be activated via menu settings.

POSSIBLE SELECTION FOR AUX INPUTS

Temperature sensor

Temperature sensor can be connected to F1226.

Available options are:

- room sensor (RTS 40)
- external supply line (BT25) (control of temperature to the heating system)

Monitor

Available options are:

- alarm from external units. The alarm is connected to the control, which means that the malfunction is presented as an information message in the display. Potential-free signal of type NO or NC.
- level (accessory NV10)/, pressure/flow monitor for the brine (NC).
- pressure switch for climate system (NC).

External activation of functions

An external switch function can be connected to F1226 to activate various functions. The function is activated during the time the switch is closed.

Possible functions that can be activated:

- forced control of brine pump
- hot water comfort mode "temporary lux"
- hot water comfort mode "economy"
- "external adjustment"

When the switch is closed, the temperature changes in °C (if the room sensor is connected and activated). If a room sensor is not connected or not activated, the desired change of "temperature" (heating curve offset) is set with the number of steps selected. The value is adjustable between -10 and +10. External adjustment of climate systems 2 to 8 requires accessories.

– climate system 1 to 8

The value for the change is set in menu 1.9.2, "external adjustment".

- activation of one of four fan speeds.
(Can be selected if ventilation accessory is activated.)
The following five options are available:
 - 1-4 is normally open (NO)
 - 1 is normally closed (NC)

The fan speed is activated during the time the switch is closed. Normal speed is resumed when the switch is opened again.

- +Adjust

Using +Adjust, the installation communicates with the underfloor heating's control centre* and adjusts the heating curve and calculated supply temperature according to the underfloor heating system's reconnection.

Activate the climate system you want +Adjust to affect by highlighting the function and pressing the OK button.

*Support for +Adjust required



Caution

This accessory may require a software update in your F1226. The version can be checked in the "Service info" menu 3.1. Visit nibeuplink.com and click on the "Software" tab to download the latest software to your installation.



Caution

In systems with both underfloor heating and radiators, NIBE ECS 40/41 should be used for optimum operation.

- SG ready



Caution

This function can only be used in mains networks that support the "SG Ready" standard. "SG Ready" requires two AUX inputs.

"SG Ready" is a smart form of tariff control where your electricity supplier can affect the indoor and hot water temperatures or simply block the additional heat and/or the compressor in the heat pump at certain times of the day (can be selected in menu 4.1.5 after the function is activated). Activate the function by connecting potential-free switch functions to two inputs selected in menu 5.4 (SG Ready A and SG Ready B).

Closed or open switch means one of the following:

– *Blocking (A: Closed, B: Open)*

"SG Ready" is active. The compressor in the heat pump and additional heat is blocked like the day's tariff blocking.

– *Normal mode (A: Open, B: Open)*

"SG Ready" is not active. No effect on the system.

– *Low price mode (A: Open, B: Closed)*

"SG Ready" is active. The system focuses on costs savings and can for example exploit a low tariff from the electricity supplier or over-capacity from any own power source (effect on the system can be adjusted in the menu 4.1.5).

– *Overcapacity mode (A: Closed, B: Closed)*

"SG Ready" is active. The system is permitted to run at full capacity at over capacity (very low price) with the electricity supplier (effect on the system is settable in menu 4.1.5).

(A = SG Ready A and B = SG Ready B)

External blocking of functions

An external switch function can be connected to F1226 for blocking various functions. The switch must be potential-free and a closed switch results in blocking.



NOTE

Blocking entails a risk of freezing.

Functions that can be blocked:

- heating (blocking of heating demand)
- hot water (hot water production). Any hot water circulation (HWC) remains in operation.
- compressor
- internally controlled additional heat
- tariff blocking (additional heat, compressor, heating and hot water are disconnected)

Connecting accessories

Instructions for connecting accessories are in the installation instructions provided for the respective accessory. See information at nibe.eu for the list of the accessories that can be used with F1226.

6 Commissioning and adjusting

Preparations

1. Check that the switch (SF1) is in position " ⏻".
2. Check for water in the hot water heater and climate system.



Caution

Check the miniature circuit-breaker and the motor protection breakers. They may have tripped during transportation.



NOTE

Do not start F1226 if there is a risk that the water in the system has frozen.

Filling and venting



Caution

Insufficient venting can damage internal components in F1226.

FILLING AND VENTING THE CLIMATE SYSTEM

Filling

1. Open the filling valve (external, not included in the product). Fill the coil in the hot water heater and the rest of the climate system with water.
2. Open the vent valve (QM22).
3. When the water that exits the vent valve (QM22) is not mixed with air, close the valve. After a while the pressure starts to rise.
4. Close the filling valve when the correct pressure is obtained.

Venting

1. Bleed the heat pump via a vent valve (QM22) and the rest of the climate system via their relevant vent valves.

2. Keep topping up and venting until all air has been removed and the pressure is correct.



NOTE

The pipe from the coil in the container must be drained of water before air can be released. This means that the system is not necessarily bled despite the flow of water when the vent valve (QM22) is opened.

FILLING THE HOT WATER HEATER

1. Open a hot water tap in the house.
2. Fill the hot water heater through the cold water connection (XL3).
3. When the water that comes out of the hot water tap is no longer mixed with air, the water heater is full and the tap can be closed.

FILLING AND VENTING THE BRINE SYSTEM

When filling the brine system, mix the water with anti-freeze in an open container. The mixture should be protected against freezing down to about -15°C. The brine is topped up by connecting a filling pump.

1. Check the brine system for leakage.
2. Connect the filling pump and return line on the brine system's filling connection (accessory).
3. If alternative 1 is used (level vessel), close the valve under the level vessel.
4. Close the reversing valve in the filling connection.
5. Open the valves on the filler connector.
6. Start the filling pump.
7. Fill until liquid enters the return pipe.
8. Close the valves on the filler connector.
9. Open the reversing valve in the filling connection.
10. If alternative 1 (level vessel) is used, open the valve under the level vessel (CM2).

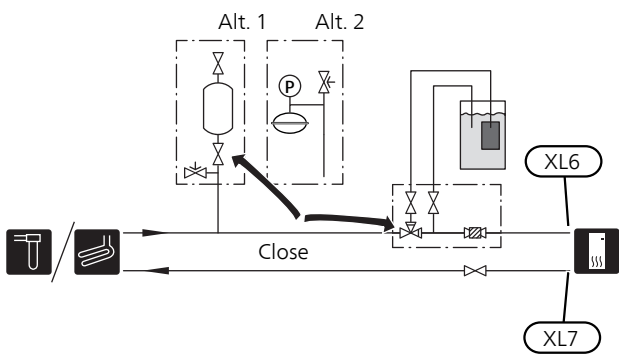

Start-up and inspection

START GUIDE



NOTE

There must be water in the climate system before the switch is set to "I".

1. Set switch (SF1) on F1226 to position "I".
2. Follow the instructions in the display's start guide. If the start guide does not start when you start the F1226, start it manually in menu 5.7.



TIP

See page 32 for a more in-depth introduction to the heat pump's control system (operation, menus etc.).

Commissioning

The first time the installation is started a start guide is started. The start guide instructions state what needs to be carried out at the first start together with a run through of the installation's basic settings.

The start guide ensures that the start-up is carried out correctly and, for this reason, cannot be skipped.



Caution

As long as the start guide is active, no function in the installation will start automatically.

The start guide will appear at each restart of the installation, until it is deselected on the last page.

Operation in the start guide

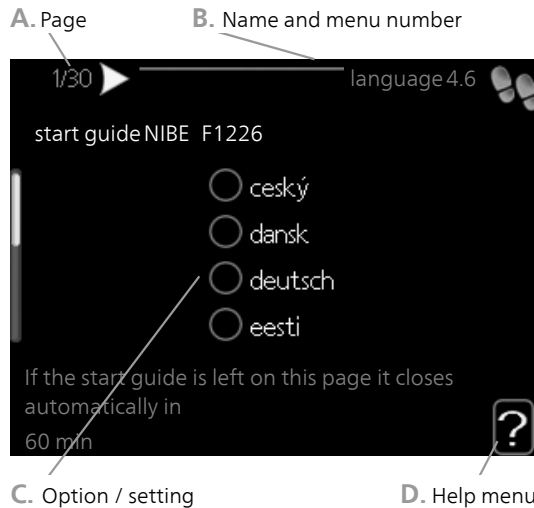

A. Page

Here you can see how far you have come in the start guide.

Scroll between the pages of the start guide as follows:

1. Turn the control knob until one of the arrows in the top left corner (at the page number) has been marked.
2. Press the OK button to skip between the pages in the start guide.

B. Name and menu number

Here, you can see which menu in the control system this page of the start guide is based on. The digits in brackets refer to the menu number in the control system.

If you want to read more about affected menus either consult the help menu or read the user manual.

C. Option / setting

Make settings for the system here.

POST ADJUSTMENT AND VENTING

Pump adjustment

Brine side, manual operation

To set the correct flow in the brine system the correct speed must be set for the brine pump.

Set the pump speed when the system has come into balance (ideally 5 minutes after compressor start).

Adjust the flow so the temperature difference between brine out (BT11) and brine in (BT10) is between 2 - 5 °C. Check these temperatures in menu 3.1 "service info" and adjust the brine pump's (GP2) speed until the temperature difference is obtained. A large difference indicates a low brine flow and a small difference indicates a high brine flow.

Read off what speed the brine pump should have from the diagrams below.

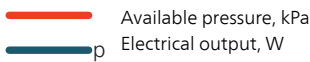

F1226 6 kW

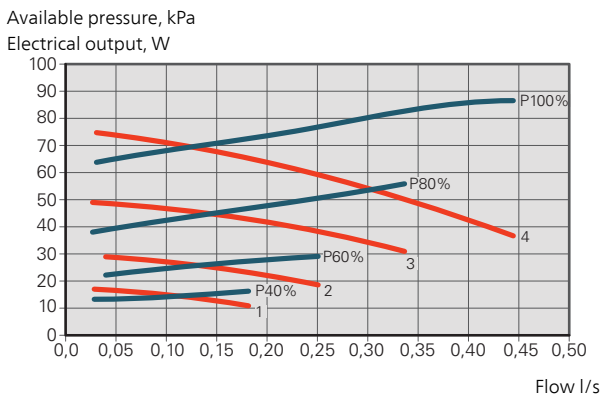

F1226 8 kW

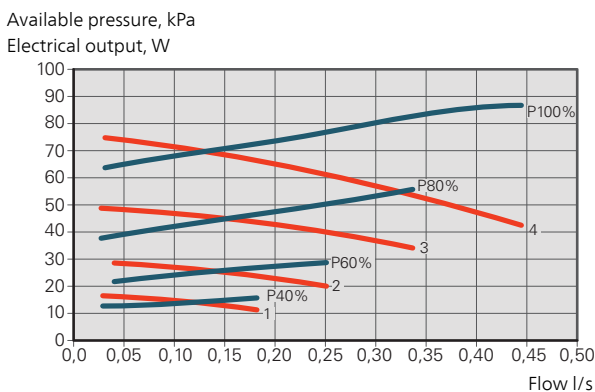

F1226 12 kW

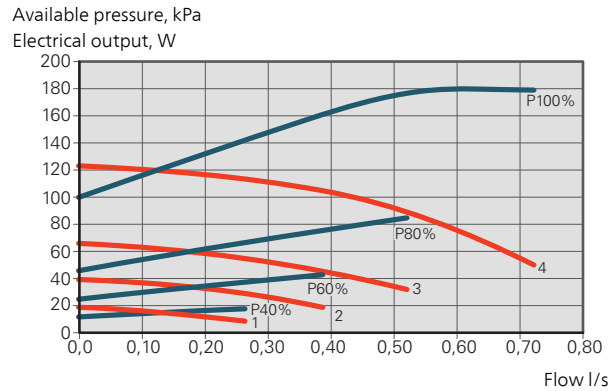

Heating medium side, manual operation

To set the correct flow in the climate system the correct speed must be set for the heating medium pump in the different operating conditions.

The flow must have a suitable temperature difference for the operating case (heating operation: 5 - 10 °C, hot water generation: 5 - 9 °C) between supply temperature sensor (BT2) and return line sensor (BT3). Check these temperatures in menu 3.1 "service info" and adjust the heating medium pump (GP1) speed until the temperature difference is attained. A high difference indicates a low heating medium flow and a low difference indicates a high heating medium flow.

Set the speed of the heating medium pump in menu 5.1.11.

Read off what speed the heating medium pump should be from the diagrams below.

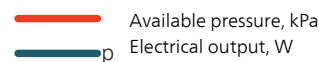

F1226 6 kW

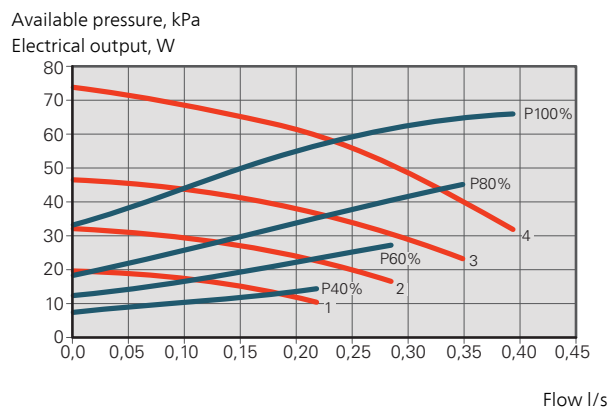

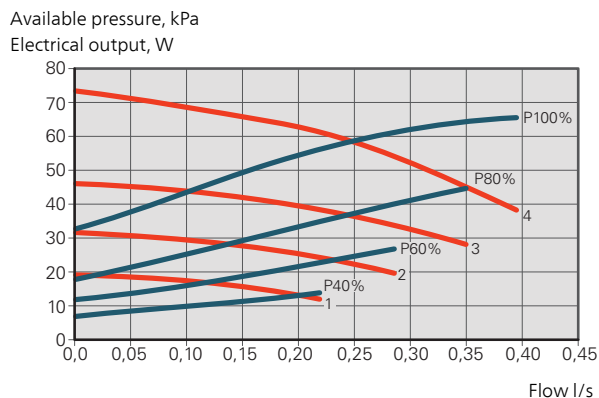

Readjusting, venting, heat medium side

Air is initially released from the hot water and venting may be necessary. If gurgling sounds can be heard from the heat pump or climate system, the entire system requires additional venting. Check the pressure in the pressure expansion vessel (CM1) with the pressure gauge (BP5). If the pressure drops, the system should be replenished.

Readjusting, venting, collector side

Level vessel

Check the fluid level in the level vessel (CM2). If the fluid level has dropped, top up the system.

1. Close the valve under the vessel.
2. Disconnect the connection on top of the vessel.
3. Fill with brine until approx 2/3 of the vessel is full.
4. Reconnect the connector at the top of the vessel.
5. Open the valve under the vessel.

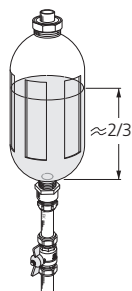

If the pressure in the system needs to be raised, this is done by closing the valve on the outgoing main line when the brine pump (GP2) is in operation and the level vessel (CM2) is open, so that liquid is drawn down from the vessel.

Expansion vessel

If a pressure expansion vessel (CM3) is used instead of a level vessel, the pressure level is checked with the pressure gauge (BP6). If the pressure drops, the system should be replenished.

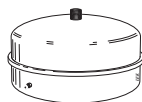

Setting the heating curve

In menu **Curve, heating** you can view the heating curve for your house. The task of the curve is to give an even indoor temperature, regardless of the outdoor temperature, and thereby energy-efficient operation. Based on this curve, the F1226 determines the temperature of the water to the climate system (the supply temperature) and thus the indoor temperature.

CURVE COEFFICIENT

The slope of the heating curve indicates how many degrees the supply temperature is to be increased/reduced when the outdoor temperature drops/increases. A steeper slope means a higher supply temperature at a certain outdoor temperature.

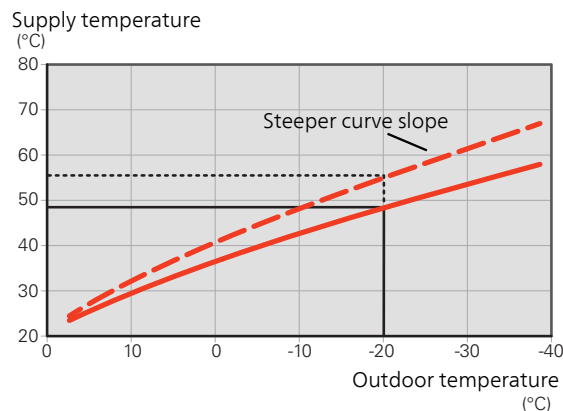

The optimum curve slope depends on the climate conditions in your location, whether the house has radiators, fan coils or underfloor heating and how well insulated the house is.

The heating curve is set when the heating installation is installed, but may need adjusting later. Normally, the curve will not need further adjustment.

CURVE OFFSET

An offset of the heating curve means that the supply temperature is changed by the same amount for all outdoor temperatures, e.g. a curve offset of +2 steps increases the supply temperature by 5 °C at all outdoor temperatures.

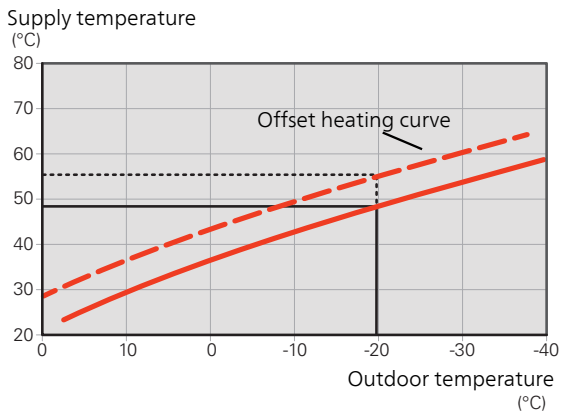

SUPPLY TEMPERATURE – MAXIMUM AND MINIMUM VALUES

Because the flow line temperature cannot be calculated higher than the set maximum value or lower than the set minimum value the heating curve flattens out at these temperatures.

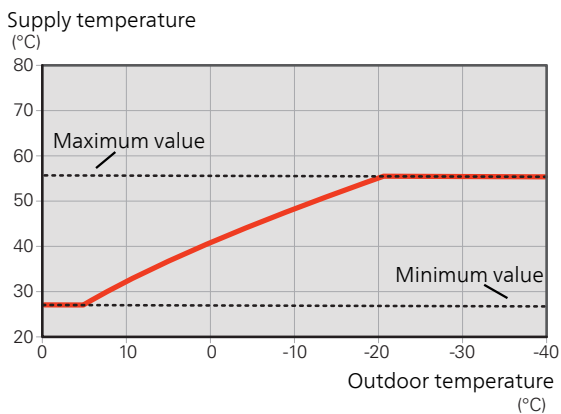

Caution

With underfloor heating systems, the maximum supply temperature is normally set between 35 and 45 °C.

Check the max floor temperature with your floor supplier.

ADJUSTMENT OF CURVE

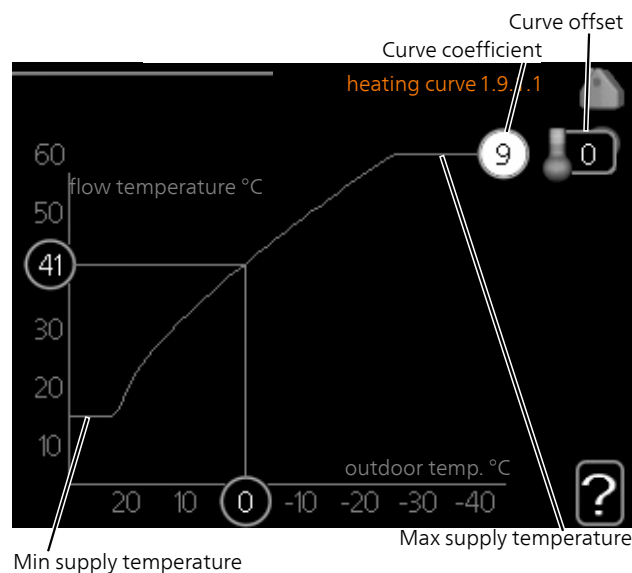

1. Select curve slope and curve offset.



Caution

If you need to adjust "min. flow line temp." and/or "max flow line temperature", you do this in other menus.

Settings for "min. flow line temp." in menu 1.9.3.

Settings for "max flow line temperature" in menu 5.1.2.



Caution

Curve 0 means that **own curve** is used.

Settings for **own curve** are made in menu 1.9.7.

TO READ OFF A HEATING CURVE

1. Turn the control knob so that the ring on the shaft with the outdoor temperature is marked.
2. Press the OK button.
3. Follow the grey line up to the curve and out to the left to read off the value for the supply temperature at the selected outdoor temperature.
4. You can now select to take read outs for different outdoor temperatures by turning the control knob to the right or left and read off the corresponding flow temperature.
5. Press the OK or Back button to exit read off mode.

7 Control - Introduction

Display unit

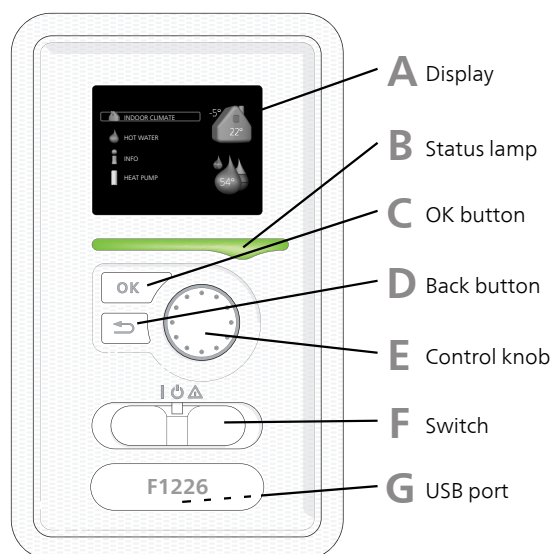

A DISPLAY

Instructions, settings and operational information are shown on the display. You can easily navigate between the different menus and options to set the comfort or obtain the information you require.

B STATUS LAMP

The status lamp indicates the status of the heat pump. It:

- lights green during normal operation.
- lights yellow in emergency mode.
- lights red in the event of a deployed alarm.

C OK BUTTON

The OK button is used to:

- confirm selections of sub menus/options/set values/page in the start guide.

D BACK BUTTON

The back button is used to:

- go back to the previous menu.
- change a setting that has not been confirmed.

E CONTROL KNOB

The control knob can be turned to the right or left. You can:

- scroll in menus and between options.
- increase and decrease the values.
- change page in multiple page instructions (for example help text and service info).

F SWITCH (SF1)

The switch assumes three positions:

- On (I)
- Standby (⏻)
- Emergency mode (⚠)

Emergency mode must only be used in the event of a fault on the heat pump. In this mode, the compressor switches off and the immersion heater engages. The heat pump display is not illuminated and the status lamp illuminates yellow.

G USB PORT

The USB port is hidden beneath the plastic badge with the product name on it.

The USB port is used to update the software.

Visit nibeuplink.com and click the "Software" tab to download the latest software for your installation.

Menu system

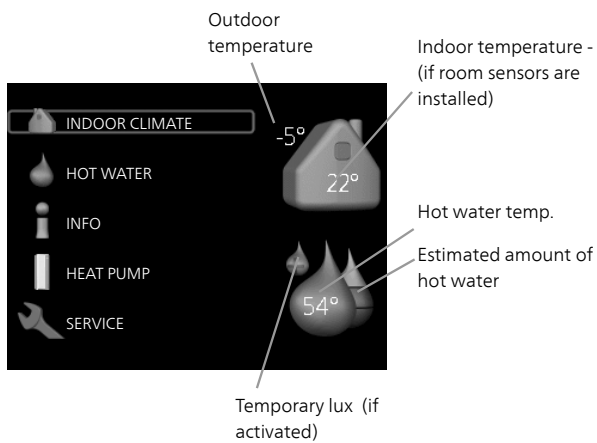

MENU 1 - INDOOR CLIMATE

Setting and scheduling the indoor climate. See information in the help menu or user manual.

MENU 2 - HOT WATER

Setting and scheduling hot water production. See information in the help menu or user manual.

MENU 3 - INFO

Display of temperature and other operating information and access to the alarm log. See information in the help menu or user manual.

MENU 4 - HEAT PUMP

Setting time, date, language, display, operating mode etc. See information in the help menu or user manual.

MENU 5 - SERVICE

Advanced settings. These settings are only intended for installers or service engineers. The menu is visible when the Back button is pressed for 7 seconds, when you are in the start menu. See page 38.

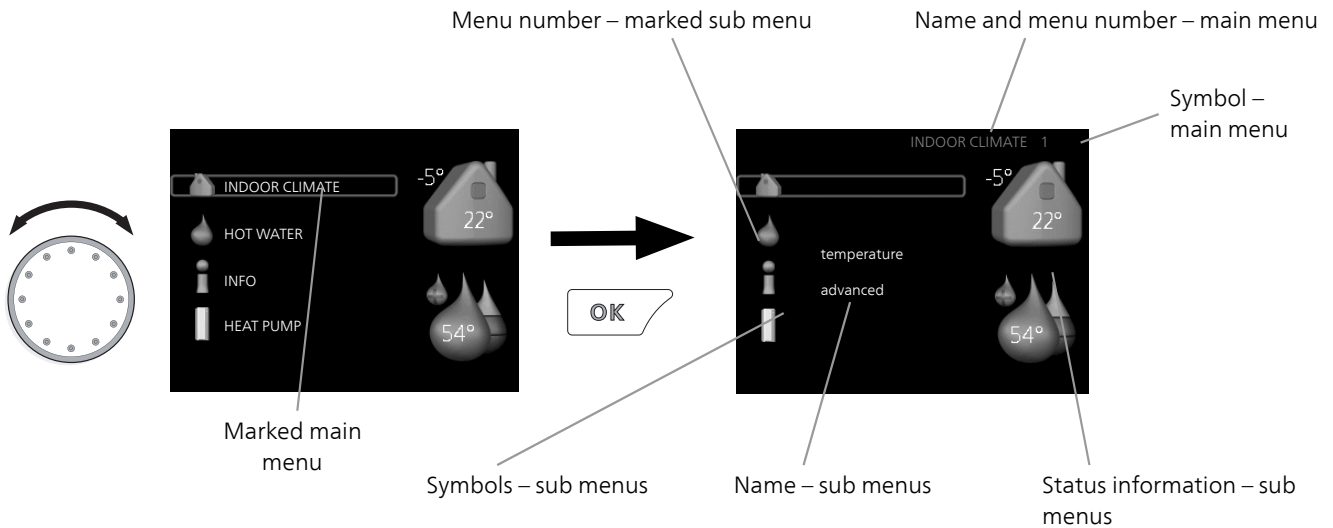

OPERATION

To move the cursor, turn the control knob to the left or the right. The marked position is brighter and/or has a light frame.



SELECTING MENU

To advance in the menu system select a main menu by marking it and then pressing the OK button. A new window then opens with sub menus.

Select one of the sub menus by marking it and then pressing the OK button.

SELECTING OPTIONS

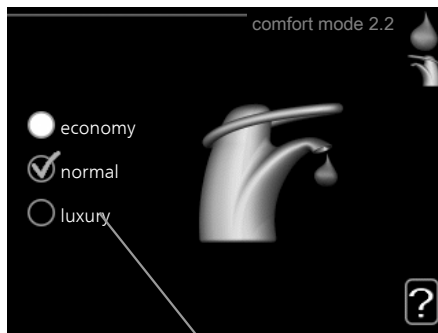



Alternative

In an options menu the current selected option is indicated by a green tick.



To select another option:

1. Mark the applicable option. One of the options is pre-selected (white). 
2. Press the OK button to confirm the selected option. The selected option has a green tick. 

SETTING A VALUE

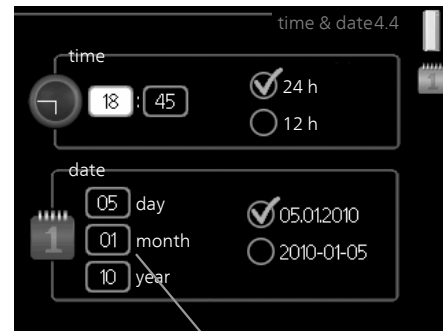

Values to be changed

To set a value:

1. Mark the value you want to set using the control knob. 01
2. Press the OK button. The background of the value becomes green, which means that you have accessed the setting mode. 01
3. Turn the control knob to the right to increase the value and to the left to reduce the value. 04
4. Press the OK button to confirm the value you have set. To change and return to the original value, press the Back button. 04

SCROLL THROUGH THE WINDOWS

A menu can consist of several windows. Turn the control knob to scroll between the windows.



Current menu window Number of windows in the menu

Scroll through the windows in the start guide



Arrows to scroll through window in start guide

1. Turn the control knob until one of the arrows in the top left corner (at the page number) has been marked.
2. Press the OK button to skip between the steps in the start guide.

HELP MENU



In many menus there is a symbol that indicates that extra help is available.

To access the help text:

1. Use the control knob to select the help symbol.
2. Press the OK button.

The help text often consists of several windows that you can scroll between using the control knob.

8 Control - Menus

Menu 1 - INDOOR CLIMATE

1 - INDOOR CLIMATE	1.1 - temperature		
	1.9 - advanced	1.9.1 - curve	1.9.1.1 - heating curve
		1.9.2 - external adjustment	
		1.9.3 - min. flow line temp.	
		1.9.4 - room sensor settings	
		1.9.7 - own curve	
		1.9.8 - point offset	

Menu 2 - HOT WATER

2 - HOT WATER	2.1 - temporary lux		
	2.2 - comfort mode		
	2.9 - advanced	2.9.1 - periodic increase	

Menu 3 - INFO

3 - INFO	3.1 - service info		
	3.2 - compressor info		
	3.3 - add. heat info		
	3.4 - alarm log		
	3.5 - indoor temp. log		

* Accessories are needed.

Menu 4 - HEAT PUMP

4 - HEAT PUMP	4.2 - op. mode
	4.4 - time & date
	4.6 - language
	4.9 - advanced
	4.9.1 - op. prioritisation
	4.9.2 - auto mode setting
	4.9.3 - degree minute setting
	4.9.4 - factory setting user

Menu 5 - SERVICE

OVERVIEW

5 - SERVICE	5.1 - operating settings	5.1.1 - hot water settings
		5.1.2 - max flow line temperature
		5.1.3 - max diff flow line temp.
		5.1.4 - alarm actions
		5.1.7 - br pmp al set.
		5.1.8 - operating mode brine pump
		5.1.9 - brine pump speed
		5.1.10 - op. mod heat med pump
		5.1.11 - pump speed heating medium
		5.1.12 - internal electrical addition
	5.2 - system settings	
	5.4 - soft in/outputs	
	5.5 - factory setting service	
	5.6 - forced control	
	5.7 - start guide	
	5.8 - quick start	
	5.10 - change log	
	5.12 - country	

Go to the main menu and hold the Back button in for 7 seconds to access the Service menu.

Sub-menus

Menu **SERVICE** has orange text and is intended for the advanced user. This menu has several sub-menus. Status information for the relevant menu can be found on the display to the right of the menus.

operating settings Operating settings for the heat pump.

system settings System settings for the heat pump, activating accessories etc.

soft in/outputs Setting software-controlled inputs and outputs on terminal block (X1).

soft in/outputs Setting software-controlled inputs and outputs on terminal block (X2).

factory setting service Total reset of all settings (including settings available to the user) to default values.

forced control Forced control of the different components in the heat pump.

start guide Manual start of the start guide which is run the first time the heat pump is started.

quick start Quick starting the compressor.



NOTE

Incorrect settings in the service menus can damage the heat pump.

MENU 5.1.1 - HOT WATER SETTINGS

start temp. economy / normal / lux

Setting range: 5 – 70 °C

Factory setting (°C):

Copper

	<i>economy</i>	<i>normal</i>	<i>luxury</i>
F1226-6	43	47	50
F1226-8	42	46	50
F1226-12	41	45	49

Stainless

	<i>economy</i>	<i>normal</i>	<i>luxury</i>
F1226-6	42	46	48
F1226-8	40	43	46
F1226-12	37	40	43

MENU 5.1 - OPERATING SETTINGS

Operating settings can be made for the heat pump in the sub menus.

stop temp. economy / normal / lux

Setting range: 5 – 70 °C

Factory setting (°C):

Copper

	<i>economy</i>	<i>normal</i>	<i>luxury</i>
F1226-6	47	51	54
F1226-8	46	50	54
F1226-12	45	49	53

Stainless

	<i>economy</i>	<i>normal</i>	<i>luxury</i>
F1226-6	46	50	52
F1226-8	44	47	50
F1226-12	41	44	47

stop temp. per. increase

Setting range: 55 – 70 °C

Factory setting: 55 °C

Here you set the start and stop temperature of the hot water for the different comfort options in menu 2.2 as well as the stop temperature for periodic increase in menu 2.9.1.

MENU 5.1.2 - MAX FLOW LINE TEMPERATURE

climate system

Setting range: 20-80 °C

Default value: 60 °C

Set the maximum supply temperature for the climate system here.



Caution

For underfloor heating systems, max flow line temperature should normally be set to between 35 and 45°C.

Check the max floor temperature with your floor supplier.

MENU 5.1.3 - MAX DIFF FLOW LINE TEMP.

max diff compressor

Setting range: 1 – 25 °C

Default value: 10 °C

max diff addition

Setting range: 1 – 24 °C

Default value: 7 °C

Here you set the maximum permitted difference between the calculated and actual supply temperature in the event of compressor or additional heat mode respectively. Max diff. additional heat can never exceed max diff. compressor

max diff compressor

If the current supply temperature *exceeds* the calculated supply by set value, the degree minute value is set to +2. The compressor in the heat pump stops if there is only a heating demand.

max diff addition

If "addition" is selected and activated in menu 4.2 and the current supply temperature *exceeds* the calculated temperature by the set value, the additional heat is forced to stop.

MENU 5.1.4 - ALARM ACTIONS

Select how you want the heat pump to alert you that there is an alarm in the display here.

The different alternatives are that the heat pump stops producing hot water (default setting) and/or reduces the room temperature.



Caution

If no alarm action is selected, it can result in higher energy consumption in the event of an alarm.

MENU 5.1.7 - BR PMP AL SET.

min. brine out

Setting range: -12 – 15 °C

Default value: -8 °C

max brine in

Setting range: 10 – 30 °C

Default value: 30 °C

min. brine out

Set the temperature at which the heat pump is to activate the alarm for low temperature in outgoing brine.

If "automatic reset" is selected, the alarm resets when the temperature has increased by 1 °C below the set value.

max brine in

Set the temperature at which the heat pump is to activate the alarm for high temperature in incoming brine.

MENU 5.1.8 - OPERATING MODE BRINE PUMP

op. mode

Setting range: intermittent, continuous, 10 days continuous

Default value: intermittent

Set the operating mode of the brine pump here.

intermittent: The brine pump starts approx. 20 seconds before and stops approx. 20 seconds after the compressor.

continuous: Continuous operation.

10 days continuous: Continuous operation for 10 days. The pump then shifts to intermittent operation.



TIP

You can use "10 days continuous" at start-up to obtain continuous circulation during a start-up time in order to make it easier to bleed the system.

MENU 5.1.9 - BRINE PUMP SPEED

Setting range: 0 - 100 %

Default values: 50 %

Set the speed of the brine pump here.

MENU 5.1.10 - OP. MOD HEAT MED PUMP

op. mode

Setting range: auto, intermittent, continuous

Default value: auto

Set the operating mode of the heating medium pump here.

auto: The heating medium pump runs according to the current operating mode for F1226.

intermittent: The heating medium pump starts approx. 20 seconds before, and stops at the same time as, the compressor.

continuous: Continuous operation.

MENU 5.1.11 - PUMP SPEED HEATING MEDIUM

Operating status

Setting range: 1 - 100 %

Factory setting: 70 %

speed in wait mode

Setting range: 1 - 100 %

Factory setting: 30 %

Set the speed at which the heat pump is to operate in the present operating mode.

"*heating*" means heating operating mode for the heating medium pump.

"*hot water*" means hot water operating mode for the heating medium pump.

"*speed in wait mode*" is the heat pump speed when neither compressor nor electric additional heat are active.

MENU 5.1.12 - INTERNAL ELECTRICAL ADDITION

max connected el. add.

Setting range: 7 / 9

Default value: 7

set max electrical add.

Setting range: 0 - 9 kW

Factory setting: 6 kW

Here you set the max. electrical output of the internal electrical addition in F1226 and the fuse size for the installation.

MENU 5.4 - SOFT IN/OUTPUTS

Here, you can select which input on the terminal block (X1) the external contact function (page 25) must be connected to.

Selectable inputs on terminal block AUX 1-2 (X1:3-6).

MENU 5.5 - FACTORY SETTING SERVICE

All settings can be reset (including settings available to the user) to default values here.



Caution

When resetting, the start guide is displayed the next time the heat pump is restarted.

MENU 5.6 - FORCED CONTROL

You can force control the different components in the heat pump and any connected accessories here.



NOTE

Forced control is only intended to be used for troubleshooting purposes. Using the function in any other way may cause damage to the components in your climate system.

MENU 5.7 - START GUIDE

When the heat pump is started for the first time the start guide starts automatically. Start it manually here.

See page 28 for more information about the start guide.

MENU 5.8 - QUICK START

It is possible to start the compressor from here.



Caution

There must be a heating or hot water demand to start the compressor.



NOTE

Do not quick start the compressor too many times over a short period of time, as this could damage the compressor and its surrounding equipment.

MENU 5.10 - CHANGE LOG

Read off any previous changes to the control system here.

The date, time, ID no. (unique to particular setting) and the new set value are shown for every change.



Caution

The change log is saved at restart and remains unchanged after factory setting.

5.12 - COUNTRY

Select here the country in which the product was installed. This allows access to country-specific settings in your product.

Language settings can be made regardless of this selection.



Caution

This option locks after 24 hours, after restarting the display or program updating.

9 Service

Service actions



NOTE

Servicing should only be carried out by persons with the necessary expertise.

When replacing components on F1226 only replacement parts from NIBE may be used.

EMERGENCY MODE



NOTE

The switch (SF1) must not be moved to "I" or "⚠" until F1226 has been filled with water. Component parts in the product can be damaged.

Emergency mode is used in event of operational interference and in conjunction with service. Hot water is not produced in emergency mode.

Emergency mode is activated by setting switch (SF1) in mode "⚠". This means that:

- The status lamp illuminates yellow.
- The display is not lit and the control computer is not connected.
- The temperature at the immersion heater is controlled by the thermostat (FQ10). It can be set either to 35 or 45 °C.
- The compressor and the brine system are off and only the heating medium pump and the electric additional heat are active. The additional heat power in emergency mode is set in the immersion heater board (AA1). See page 24 for instructions.

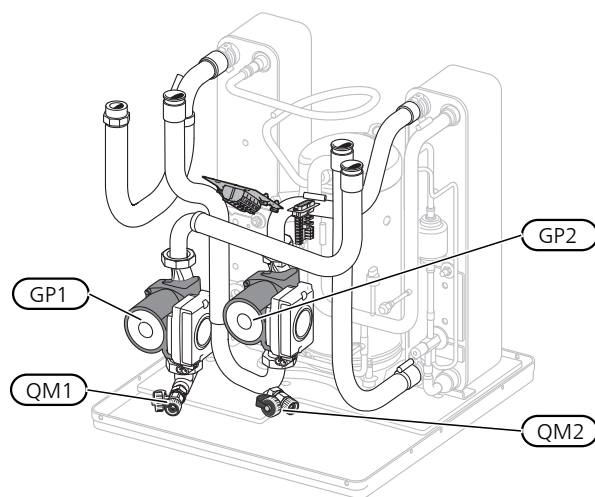

The image shows an example of what a cooling section could look like.

DRAINING THE HOT WATER HEATER

The siphon principle is used to empty the hot water heater. This can be done either via the drain valve on the incoming cold water pipe or by inserting a hose into the cold water connection.

DRAINING THE CLIMATE SYSTEM

In order to carry out service on the climate system, it may be easier to drain the system first. This can be done in different ways depending on what needs doing:



NOTE

There may be some hot water when draining the heating medium side/climate system. There is a risk of scalding.

Draining the heating medium side in the cooling module

If, for example, the heating medium pump requires replacing or the cooling module requires servicing, drain the heating medium side as follows:

1. Close the shut-off valves to heating medium side (QM31) and (QM32).
2. Connect a hose to the bleed valve (QM1) and open the valve. Some liquid will run out.

- Air must get into the system for the remaining liquid to run out. To let in air, slacken off the connection slightly at the shut-off valve (QM32) that joins the heat pump with the cooling module.

When the heating medium side is empty, the required service can be carried out and/or replacement of any components carried out.

Draining the heating medium system in the heat pump

If F1226 requires servicing, drain the heating medium side as follows:

- Close the shut-off valves outside the heat pump for the heating medium side (return and flow line).
- Connect a hose to the bleed valve (QM1) and open the valve. Some liquid will run out.
- Air must get into the system for the remaining liquid to run out. To let in air, slacken off the connection slightly at the shut-off valve that joins the heat pump with the cooling module (XL2).

When the heating medium side is empty, the required service can be carried out.

Draining the entire climate system

If the entire climate system requires draining, do this as follows:

- Connect a hose to the bleed valve (QM1) and open the valve. Some liquid will run out.
- Air must get into the system for the remaining liquid to run out. To allow air in, unscrew the bleed screw on the highest radiator in the house.

When the climate system is empty, the required service can be carried out.

EMPTYING THE BRINE SYSTEM

In order to service the brine system it may be easier to drain the system first. This can be done in different ways depending on what needs doing:

Draining the brine system in the cooling module

If, for example, the brine pump requires replacing or the cooling module requires servicing, drain the brine system by:

- Close the shut-off valves to brine system (QM33) and (QM34).
- Connect a hose to the drain valve (QM2), place the other opening of the hose in a container and open the valve. A small amount of brine will flow into the container.
- Air must get into the system in order for the remaining brine to run out. To let in air, slacken off the connection slightly at the shut-off valve (QM33) that joins the heat pump with the cooling module.

When the brine system is empty, the required service can be carried out.

Draining the brine system in the heat pump

If the heat pump requires servicing, drain the brine system by:

- Close the shut-off valve outside the heat pump for the brine system.
- Connect a hose to the drain valve (QM2), place the other opening of the hose in a container and open the valve. A small amount of brine will flow into the container.
- Air must get into the system for the remaining brine to run out. To let in air, slacken off the connection slightly at the shut-off valve that joins the brine side with the heat pump at connection (XL7).

When the brine system is empty, the required service can be carried out.

HELPING THE CIRCULATION PUMP TO START

- Turn off F1226 by setting the switch (SF1) to "⏻".
- Remove the front cover
- Remove the cover for the cooling module.
- Loosen the venting screw (QM5) with a screwdriver. Hold a cloth around the screwdriver blade as a small amount of water may run out.
- Insert a screwdriver and turn the pump motor around.
- Screw in the venting screw (QM5).
- Start F1226 by setting the switch (SF1) to "I" and check that the circulation pump is working.

It is usually easier to start the circulation pump with F1226 running, and with the switch (SF1) set to "I". If the circulation pump is helped to start while F1226 is running, be prepared for the screwdriver to jerk when the pump starts.

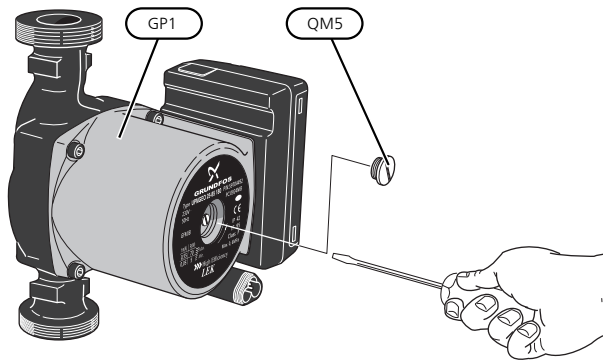

The image shows an example of what a circulation pump can look like.

TEMPERATURE SENSOR DATA

Temperature (°C)	Resistance (kOhm)	Voltage (VDC)
-40	351.0	3.256
-35	251.6	3.240
-30	182.5	3.218
-25	133.8	3.189
-20	99.22	3.150
-15	74.32	3.105
-10	56.20	3.047
-5	42.89	2.976
0	33.02	2.889
5	25.61	2.789
10	20.02	2.673
15	15.77	2.541
20	12.51	2.399
25	10.00	2.245
30	8.045	2.083
35	6.514	1.916
40	5.306	1.752
45	4.348	1.587
50	3.583	1.426
55	2.968	1.278
60	2.467	1.136
65	2.068	1.007
70	1.739	0.891
75	1.469	0.785
80	1.246	0.691
85	1.061	0.607
90	0.908	0.533
95	0.779	0.469
100	0.672	0.414

PULLING OUT THE COOLING MODULE

The cooling module can be pulled out for service and transport.



NOTE

Switch off the heat pump and cut the power with the safety switch.



Caution

Remove the front cover according to the description on page 8.

1. Close the shut-off valves (QM31), (QM32), (QM33) and (QM34).

Drain the compressor module according to the instructions on page 42

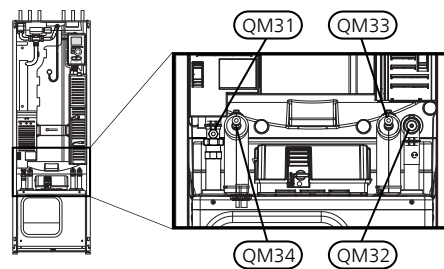

2. Pull off the lock catches.
3. Disconnect the pipe connection under the shut-off valve (QM31).

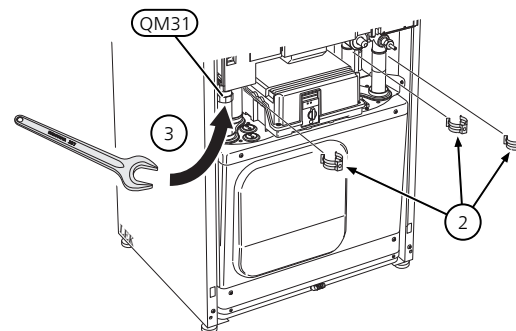

4. Remove the two screws.

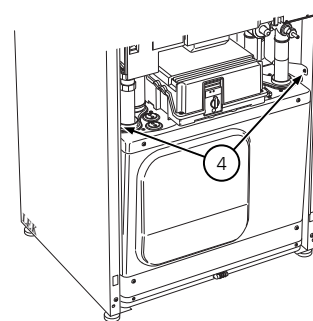

5. Remove the connections from the base card (AA2) using a screwdriver.

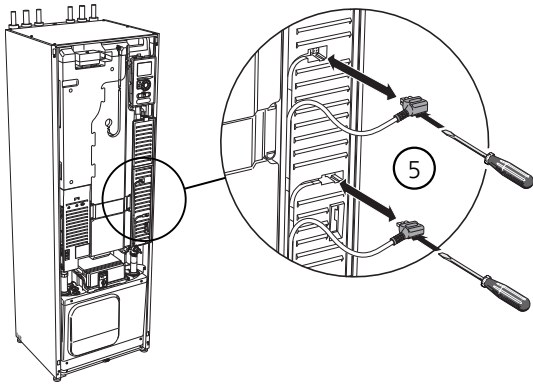

6. Disconnect the connectors (A) and (B) from the underside of the base card cabinet.
7. Disconnect the connector (C) from the electric addition PCB (AA1) using a screwdriver.
8. Disconnect the switch (D) from the joint board (AA100).
9. Carefully pull out the cooling module.

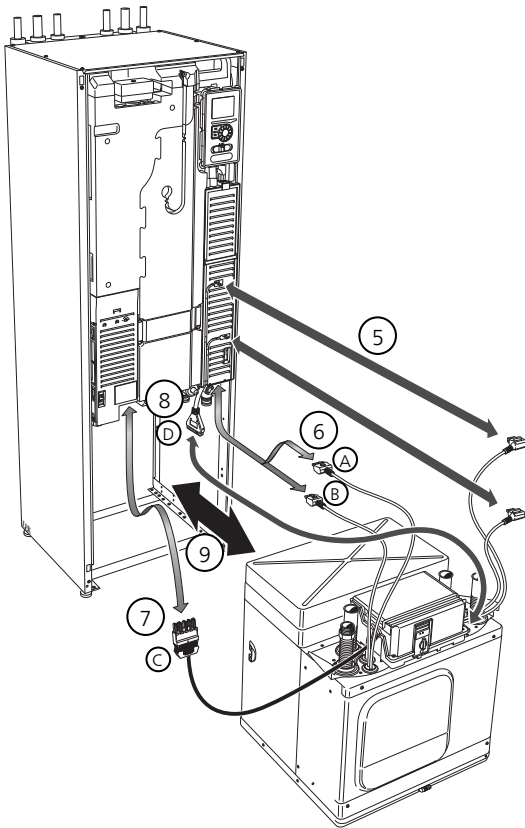

TIP

The cooling module is installed in reverse order.



NOTE

At reinstallation, the supplied O-rings must replace the existing ones at the connections to the heat pump (see image).

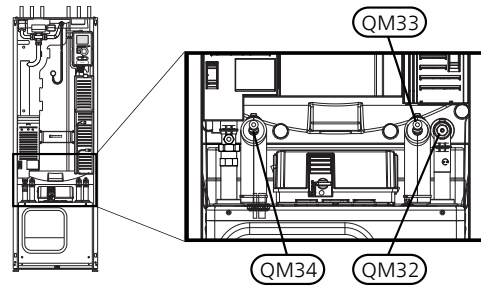

USB SERVICE OUTLET

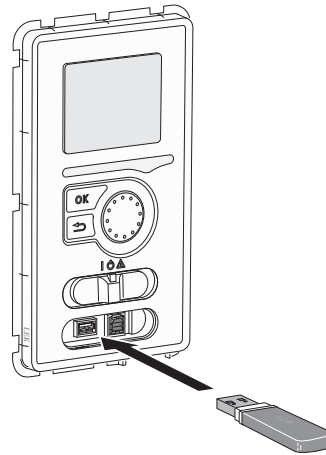

The display unit is equipped with a USB socket that can be used to update the software and save logged information in F1226.

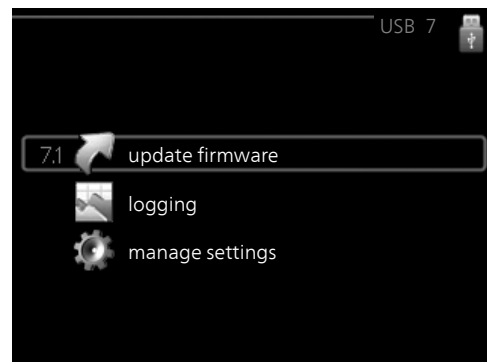
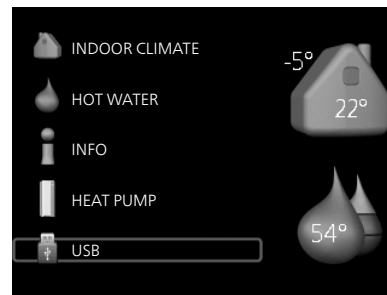

When a USB memory is connected, a new menu (menu 7) appears in the display.

Menu 7.1 - update firmware

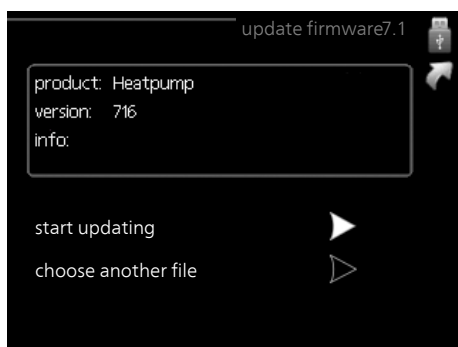

This allows you to update the software in F1226.



NOTE

For the following functions to work the USB memory must contain files with software for F1226 from NIBE.

The fact box at the top of the display shows information (always in English) of the most probable update that the update software has selected from the USB memory.

This information states the product for which the software is intended, the software version and general information about it. If you want a file other than the one selected, the correct file can be selected through "choose another file".

start updating

Select "start updating" if you want to start the update. You are asked whether you really want to update the software. Respond "yes" to continue or "no" to undo.

If you responded "yes" to the previous question the update starts and you can now follow the progress of the update on the display. When the update is complete F1226 restarts.



TIP

A software update does not reset the menu settings in F1226.



Caution

If the update is interrupted before it is complete (for example power cut etc.), the software can be reset to the previous version if the OK button is held in during start up until the green lamp starts to illuminate (takes about 10 seconds).

choose another file

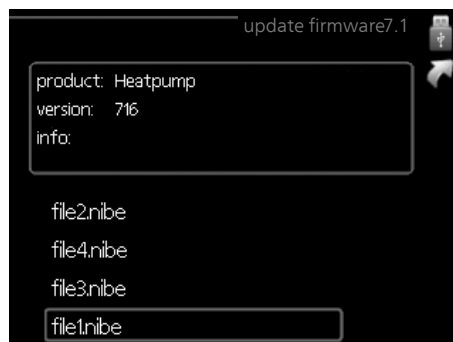

Select "choose another file" if you do not want to use the suggested software. When you scroll through the files, information about the marked software is shown in a fact box just as before. When you have selected a file with the OK button you will return to the previous page (menu 7.1) where you can choose to start the update.

Menu 7.2 - logging



Setting range: 1 s – 60 min

Factory setting range: 5 s

Here you can choose how current measurement values from F1226 should be saved onto a log file on the USB memory.

1. Set the desired interval between loggings.
2. Tick "activated".
3. The present values from F1226 are saved in a file in the USB memory at the set interval until "activated" is unticked.



Caution

Untick "activated" before removing the USB memory.

Menu 7.3 - manage settings

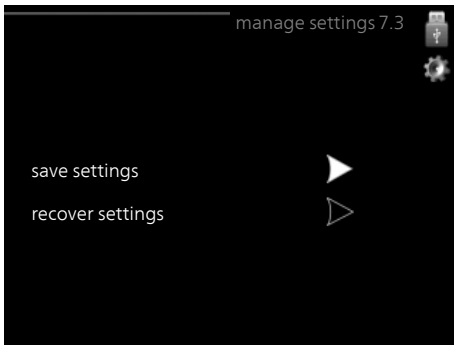

Here you can manage (save as or retrieve from) all the menu settings (user and service menus) in F1226 with a USB memory.

Via "save settings" you save the menu settings to the USB memory in order to restore them later or to copy the settings to another F1226.



Caution

When you save the menu settings to the USB memory you replace any previously saved settings on the USB memory.

Via "recover settings" you reset all menu settings from the USB memory.



Caution

Reset of the menu settings from the USB memory cannot be undone.

10 Disturbances in comfort

In most cases, F1226 notes a malfunction (a malfunction can lead to disruption in comfort) and indicates this with alarms, and instructions for action, in the display.

INFO MENU

All the heat pump measurement values are gathered under menu 3.1 in the heat pump menu system. Looking through the values in this menu can often simplify finding the source of the fault. See help menu or user manual for more information about menu 3.1.

Manage alarm

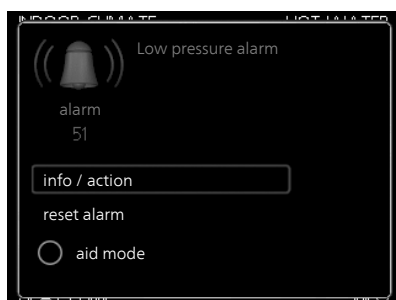

In the event of an alarm, some kind of malfunction has occurred, which is indicated by the status lamp changing from green continuously to red continuously. In addition, an alarm bell appears in the information window.

ALARM

In the event of an alarm with a red status lamp a malfunction has occurred that the heat pump cannot remedy itself. In the display, by turning the control knob and pressing the OK button, you can see the type of alarm it is and reset it. You can also choose to set the heat pump to aid mode.

info / action Here you can read what the alarm means and receive tips on what you can do to correct the problem that caused the alarm.

reset alarm In many cases, it is sufficient to select "reset alarm" for the product to revert to normal operation. If a green light comes on after selecting "reset alarm", the alarm has been remedied. If the red light is still on, and a menu called "alarm" is visible in the display, the problem causing the alarm still remains.

aid mode "aid mode" is a type of emergency mode. This means that the heat pump produces heat and/or hot water even though there is some kind of problem. This could mean that the heat pump's compressor is not running. In this case, the immersion heater produces heat and/or hot water.



Caution

To select aid mode an alarm action must be selected in the menu 5.1.4.



Caution

Selecting "aid mode" is not the same as correcting the problem that caused the alarm. The status lamp will therefore continue to be red.

Troubleshooting

If the operational interference is not shown in the display the following tips can be used:

BASIC ACTIONS

Start by checking the following items:

- The switch's (SF1) position.
- Group and main fuses of the accommodation.
- The property's earth circuit breaker.
- Miniature circuit breaker for F1226 (FC1).

LOW HOT WATER TEMPERATURE OR NO HOT WATER

- Mixing valve (if there is one installed) set too low.
 - Adjust the mixer valve.
- F1226 in incorrect operating mode.
 - Enter menu 4.2. If mode "auto" is selected, select a higher value on "stop additional heat" in menu 4.9.2.
 - If mode "manual" is selected, select "addition".
- Large hot water consumption.

- Wait until the hot water has heated up. Temporarily increased hot water capacity (temporary lux) can be activated in menu 2.1.
- Too low hot water setting.
 - Enter menu 2.2 and select a higher comfort mode.
- Too low or no operating prioritisation of hot water.
 - Enter menu 4.9.1 and increase the time for when hot water is to be prioritised. Note that, if the time for hot water is increased, the time for heating production is reduced, which can give lower/uneven room temperatures.

LOW ROOM TEMPERATURE

- Closed thermostats in several rooms.
 - Set the thermostats to max, in as many rooms as possible. Adjust the room temperature via menu 1.1, instead of choking the thermostats.
 - See the "Saving tips" section in the User manual for more detailed information about how to best set the thermostats.
- Too low set value on the automatic heating control.
 - Enter menu 1.1 "temperature" and adjust the offset heating curve up. If the room temperature is only low in cold weather the curve slope in menu 1.9.1 "heating curve" needs adjusting up.
- F1226 in incorrect operating mode.
 - Enter menu 4.2. If mode "auto" is selected, select a higher value on "stop heating" in menu 4.9.2.
 - If mode "manual" is selected, select "heating". If this is not enough, select "addition".
- Too low or no operating prioritisation of heat.
 - Enter menu 4.9.1 and increase the time for when heating is to be prioritised. Note that if the time for heating is increased the time for hot water production is reduced, which can give smaller amounts of hot water.
- External switch for changing room temperature activated.
 - Check any external switches.
- Air in the climate system.
 - Vent the climate system (see page 27).
- Closed valves to the climate system.
 - Open the valves.

HIGH ROOM TEMPERATURE

- Too high set value on the automatic heating control.

- Enter menu 1.1 (temperature) and reduce the offset heating curve. If the room temperature is only high in cold weather the curve slope in menu 1.9.1 "heating curve" needs adjusting down.

- External switch for changing room temperature activated.
 - Check any external switches.

UNEVEN ROOM TEMPERATURE.

- Incorrectly set heating curve.
 - Fine-tune the heating curve in menu 1.9.1
- Too high set value on "dT at DOT"..
 - Enter menu 5.1.14 (flow set. climate system) and reduce the value of "dT at DOT".
- Uneven flow over the radiators.
 - Adjust the flow distribution between the radiators.

LOW SYSTEM PRESSURE

- Not enough water in the climate system.
 - Top up the water in the climate system (see page 27).

COMPRESSOR DOES NOT START

- There is no heating requirement.
 - F1226 does not call on heating or hot water.
- Compressor blocked due to the temperature conditions.
 - Wait until the temperature is within the product's working range.
- Minimum time between compressor starts has not been reached.
 - Wait for at least 30 minutes and then check if the compressor has started.
- Alarm tripped.
 - Follow the display instructions.
- "Additional heat only" is selected.
 - Switch to "Auto" or "Manual" in menu 4.1 "Operating mode".

WHINING NOISE IN THE RADIATORS

- Closed thermostats in the rooms and incorrectly set heating curve.
 - Set the thermostats to max. in as many rooms as possible. Adjust the heating curve via menu 1.1, instead of choking the thermostats.

- Circulation pump speed set too high.
 - Enter menu 5.1.11 (pump speed heating medium) and reduce the speed of the circulation pump.
- Uneven flow over the radiators.
 - Adjust the flow distribution between the radiators.

GURGLING SOUND

This part of the troubleshooting chapter only applies if the NIBE FLM accessory is installed.

- Not enough water in the water seal.
 - Refill the water seal with water.
- Choked water seal.
 - Check and adjust the condensation water hose.

11 Accessories

Not all accessories are available on all markets.

AUXILIARY RELAY HR 10

Auxiliary relay HR 10 is used to control external 1 to 3 phase loads such as oil burners, immersion heaters and pumps.

Part no 067 309

BASE EXTENSION EF 45

This accessory is used to create a larger connection area under F1226.

Part no. 067 152

BUFFER VESSEL UKV

UKV is an accumulator tank that is suitable for connection to a heat pump or another external heat source, and can have several different applications. It can also be used during external control of the heating system.

UKV 100

Part no. 088 207

UKV 200

Part no. 080 300

EXHAUST AIR MODULE NIBE FLM

NIBE FLM is an exhaust air module designed to combine recovery of mechanical exhaust air with ground source heating.

NIBE FLM

Part no. 067 011

Bracket BAU 40

Part no. 067 666

EXTRA RELAY CARD EXC 40

Extra relay board required if ground water pump and/or hot water circulation pump is to be connected to F1226.

The extra relay card is installed inside the heat pump.

Part no. 067 072

FILLING VALVE KIT KB 25

Valve kit for filling brine in the collector hose. Includes particle filter and insulation.

KB 25 (max. 12 kW)

Part no 089 368

LEVEL MONITOR NV 10

Level monitor for extended checks of the brine level.

Part no. 089 315

LOAD MONITOR EBV 200

EBV 200 is a two-stage electronic load monitor used to disconnect output that exceeds the output set on the load monitor.

Part no. 418 346

ROOM SENSORRTS 40

This accessory is used to obtain a more even indoor temperature.

Part no. 067 065

12 Technical data

Dimensions and setting-out coordinates

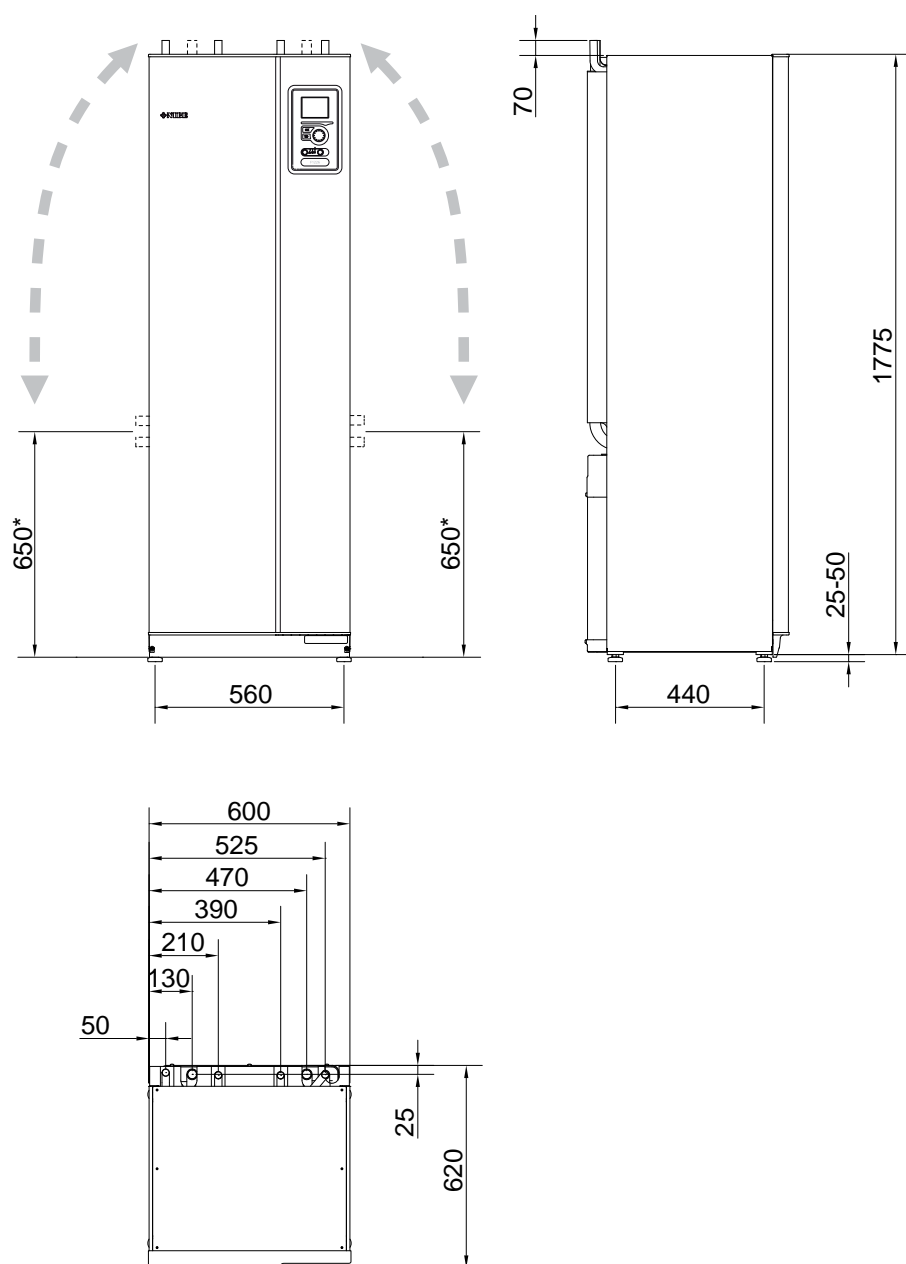

* This dimension applies at 90° angle on the brine pipes (side connection). The dimension can vary approx. ±100 mm vertically as the brine pipes consist in part of flexible pipes.

Electrical data

3X400 V

F1226-6		
Rated voltage		400V 3N ~ 50Hz
Starting current	A_{rms}	13
Max operating current including 0 kW immersion heater (Recommended fuse rating).	A_{rms}	5.3(16)
Max operating current including 1 – 2 kW immersion heater (Recommended fuse rating).	A_{rms}	13(16)
Max operating current including 3 – 4 kW immersion heater (Recommended fuse rating).	A_{rms}	13(16)
Max operating current including 5 – 6 kW immersion heater (Recommended fuse rating).	A_{rms}	17(20)
Max operating current including 7 kW immersion heater, connected on delivery (Recommended fuse rating).	A_{rms}	17(20)
Max operating current including 9 kW immersion heater, requires reconnection (Recommended fuse rating).	A_{rms}	20(20)
Additional power	kW	1/2/3/4/5/6/7 (switchable to 2/4/6/9)
Output, Brine pump	W	5 – 87
Output, Heating medium pump	W	4 – 70
Enclosure class		IPX1B
Equipment Compliant with IEC 61000-3-12		
For Connection Design Purposes, Compliant with IEC 61000-3-3 technical requirements		

F1226-8		
Rated voltage		400V 3N ~ 50Hz
Starting current	A_{rms}	16
Max operating current including 0 kW immersion heater (Recommended fuse rating).	A_{rms}	6.4(16)
Max operating current including 1 – 2 kW immersion heater (Recommended fuse rating).	A_{rms}	14(16)
Max operating current including 3 – 4 kW immersion heater (Recommended fuse rating).	A_{rms}	14(16)
Max operating current including 5 – 6 kW immersion heater (Recommended fuse rating).	A_{rms}	18(20)
Max operating current including 7 kW immersion heater, connected on delivery (Recommended fuse rating).	A_{rms}	18(20)
Max operating current including 9 kW immersion heater, requires reconnection (Recommended fuse rating).	A_{rms}	21(25)
Additional power	kW	1/2/3/4/5/6/7 (switchable to 2/4/6/9)
Output, Brine pump	W	5 – 87
Output, Heating medium pump	W	4 – 70
Enclosure class		IPX1B
Equipment Compliant with IEC 61000-3-12		
For Connection Design Purposes, Compliant with IEC 61000-3-3 technical requirements		

F1226-12		
Rated voltage		400V 3N ~ 50Hz
Starting current	A_{rms}	29
Max operating current including 0 kW immersion heater (Recommended fuse rating).	A_{rms}	9(16)
Max operating current including 1 – 2 kW immersion heater (Recommended fuse rating).	A_{rms}	18(20)
Max operating current including 3 – 4 kW immersion heater (Recommended fuse rating).	A_{rms}	18(20)
Max operating current including 5 – 6 kW immersion heater (Recommended fuse rating).	A_{rms}	18(20)
Max operating current including 7 kW immersion heater, connected on delivery (Recommended fuse rating).	A_{rms}	23(25)
Max operating current including 9 kW immersion heater, requires reconnection (Recommended fuse rating).	A_{rms}	24(25)
Additional power	kW	1/2/3/4/5/6/7 (switchable to 2/4/6/9)
Output, Brine pump	W	3 – 180
Output, Heating medium pump	W	4 – 70
Enclosure class		IPX1B
Equipment Compliant with IEC 61000-3-12		
For Connection Design Purposes, Compliant with IEC 61000-3-3 technical requirements		

Technical specifications

3X400 V

Model		F1226-6	F1226-8	F1226-12
<i>Output data according to EN 14511</i>				
<i>0/35 nominal</i>				
Heating capacity (P _H)	kW	5.39	7.73	11.52
Supplied power (P _E)	kW	1.29	1.72	2.68
COP		4.17	4.48	4.30
<i>0/45 nominal</i>				
Heating capacity (P _H)	kW	5.05	7.36	10.88
Supplied power (P _E)	kW	1.55	2.04	3.14
COP		3.26	3.62	3.46
<i>SCOP according to EN 14825</i>				
Rated heating output (P _{designh})	kW	7 / 6	9 / 9	13
SCOP cold climate, 35 °C / 55 °C		4.5 / 3.5	4.8 / 3.8	4.6 / 3.6
SCOP average climate, 35 °C / 55 °C		4.4 / 3.4	4.7 / 3.7	4.5 / 3.5
<i>Energy rating, average climate</i>				
The product's room heating efficiency class 35 °C / 55 °C ¹		A++ / A++	A+++ / A++	A+++ / A++
The system's room heating efficiency class 35 °C / 55 °C ²		A++ / A++	A+++ / A++	A+++ / A++
Efficiency class hot water heating / declared tap profile ³		A / XL	A / XL	A / XL
<i>Noise</i>				
Sound power level (L _{WA}) _{EN 12102} at 0/35	dB(A)	42	39	44
Sound pressure level (L _{PA}) calculated values according to EN ISO 11203 at 0/35 and 1 m range	dB(A)	27	24	29
<i>Refrigerant circuit</i>				
Type of refrigerant		R407C		
GWP refrigerant		1,774		
Fill amount	kg	0.85	1.1	1.2
CO ₂ equivalent	ton	1.51	1.95	2.13
Cut-out value pressure switch HP / LP	MPa	2.9 (29 bar) / 0.15 (1.5 bar)		
<i>Brine circuit</i>				
Min/max system pressure brine	MPa	0.05 (0.5 bar) / 0.45 (4.5 bar)		
Min flow	l/s	0.22	0.30	0.43
Nominal flow	l/s	0.30	0.42	0.64
Max external avail. press at nom flow	kPa	49	39	57
Min/Max incoming Brine temp	°C	see diagram		
Min. outgoing brine temp.	°C	-10		
<i>Heating medium circuit</i>				
Min/Max system pressure heating medium	MPa	0.05 (0.5 bar) / 0.45 (4.5 bar)		
Min flow	l/s	0.09	0.12	0.18
Nominal flow	l/s	0.13	0.16	0.25
Max external avail. press at nom flow	kPa	53	47	57
Min/max HM-temp	°C	see diagram		
<i>Pipe connections</i>				
Brine ext diam. CU pipe	mm	28	28	28
Heating medium ext diam. CU pipes	mm	22	22	28
Hot water connection external diam	mm	22		
Cold water connection external diam	mm	22		
<i>Hot water and heating section</i>				
Volume water heater (Cu / Rf / E) ⁴	l	178 / 176 / -		
Max pressure in water heater	MPa	1.0 (10 bar)		
<i>Hot water heating capacity (comfort mode Normal) According to EN16147</i>				
Amount of hot water (40 °C)	l	240	235	230
COP _{DHW} (load profile XL)		2.8	2.8	2.8
<i>Dimensions and weight</i>				
Width x Depth x Height	mm	600 x 620 x 1,800		
Ceiling height ⁵	mm	1,950		
Weight complete heat pump (Cu / Rf / E) ⁴	kg	225 / 205 / -	235 / 215 / -	255 / 235 / -
Weight only cooling module	kg	100	105	126

Model		F1226-6	F1226-8	F1226-12
Substances according to Directive (EG) no. 1907/2006, article 33 (Reach)		Lead in brass components		
Part number, 3x400 V (Cu / Rf / E) ⁴		065 581 / 065 583 / -	065 582 / 065 584 / -	065 227 / 065 230 / -

- 1 Scale for the product's efficiency class room heating: A+++ to D.
- 2 Scale for the system's efficiency class room heating: A+++ to G. Reported efficiency for the system takes the product's temperature regulator into account.
- 3 Scale for efficiency class hot water: A+ to F.
- 4 Cu: copper, Rf: stainless steel, E: enamel.
- 5 With feet removed, the height is approx. 1,930 mm.

WORKING RANGE HEAT PUMP, COMPRESSOR OPERATION

The compressor provides a supply temperature up to 63 °C at 0 °C incoming brine temperature.

12 kW 3x400V

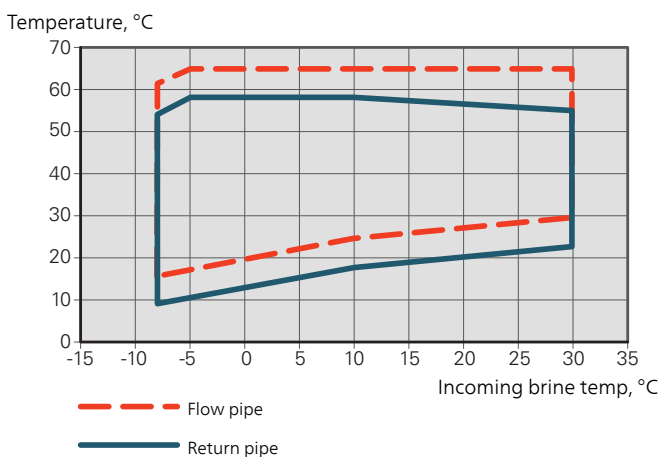

6 - 8 kW 3x400V

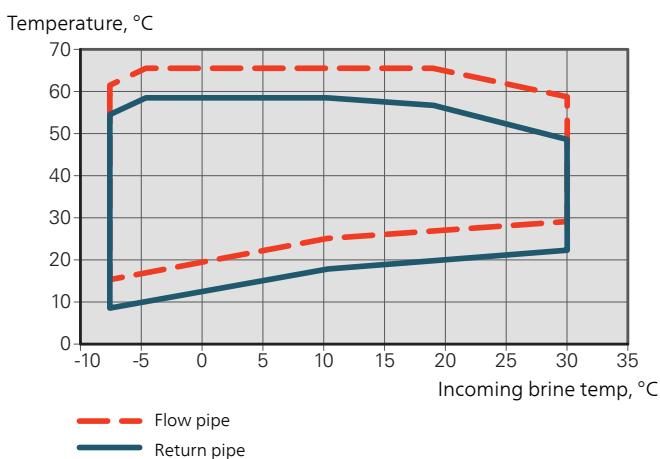

Energy labelling

INFORMATION SHEET

Supplier		NIBE AB		
Model		F1226-6 3x400V	F1226-8 3x400V	F1226-12 3x400V
Temperature application	°C	35 / 55	35 / 55	35 / 55
Declared load profile for water heating		XL	XL	XL
Seasonal space heating energy efficiency class, average climate		A++ / A++	A+++ / A++	A+++ / A++
Water heating energy efficiency class, average climate		A	A	A
Rated heat output (P _{design,h}), average climate	kW	7 / 6	9 / 9	13
Annual energy consumption space heating, average climate	kWh	3,102 / 3,757	3,978 / 4,748	5,986 / 7,628
Annual energy consumption water heating, average climate	kWh	1838	1794	1876
Seasonal space heating energy efficiency, average climate	%	168 / 128	179 / 140	171 / 133
Water heating energy efficiency, average climate	%	91	93	89
Sound power level L _{WA} indoors	dB	43	43	45
Rated heat output (P _{design,h}), cold climate	kW	7 / 6	9 / 9	13
Rated heat output (P _{design,h}), warm climate	kW	7 / 6	9 / 9	13
Annual energy consumption space heating, cold climate	kWh	3,609 / 4,364	4,630 / 5,695	6,946 / 8,874
Annual energy consumption water heating, cold climate	kWh	1838	1794	1876
Annual energy consumption space heating, warm climate	kWh	2,029 / 2,470	2,592 / 3,167	3,923 / 4,972
Annual energy consumption water heating, warm climate	kWh	1838	1794	1876
Seasonal space heating energy efficiency, cold climate	%	172 / 132	184 / 144	177 / 136
Water heating energy efficiency, cold climate	%	91	93	89
Seasonal space heating energy efficiency, warm climate	%	166 / 126	178 / 137	169 / 132
Water heating energy efficiency, warm climate	%	91	93	89
Sound power level L _{WA} outdoors	dB	-	-	-

DATA FOR ENERGY EFFICIENCY OF THE PACKAGE

Model		F1226-6 3x400V	F1226-8 3x400V	F1226-12 3x400V
Temperature application	°C	35 / 55	35 / 55	35 / 55
Controller, class		III		
Controller, contribution to efficiency	%	1.5		
Seasonal space heating energy efficiency of the package, average climate	%	169 / 130	180 / 141	173 / 134
Seasonal space heating energy efficiency class of the package, average climate		A++ / A++	A+++ / A++	A+++ / A++
Seasonal space heating energy efficiency of the package, cold climate	%	174 / 134	185 / 146	178 / 138
Seasonal space heating energy efficiency of the package, warm climate	%	167 / 128	179 / 139	171 / 133

The reported efficiency of the package also takes the controller into account. If an external supplementary boiler or solar heating is added to the package, the overall efficiency of the package should be recalculated.

TECHNICAL DOCUMENTATION

Model		F1226-6 3x400V					
Type of heat pump	<input type="checkbox"/> Air-water <input type="checkbox"/> Exhaust-water <input checked="" type="checkbox"/> Brine-water <input type="checkbox"/> Water-water						
Low-temperature heat pump	<input type="checkbox"/> Yes <input checked="" type="checkbox"/> No						
Integrated immersion heater for additional heat	<input checked="" type="checkbox"/> Yes <input type="checkbox"/> No						
Heat pump combination heater	<input checked="" type="checkbox"/> Yes <input type="checkbox"/> No						
Climate	<input checked="" type="checkbox"/> Average <input type="checkbox"/> Cold <input type="checkbox"/> Warm						
Temperature application	<input checked="" type="checkbox"/> Average (55 °C) <input type="checkbox"/> Low (35 °C)						
Applied standards	EN-14825 & EN-16147						
Rated heat output	Prated	6,2	kW	Seasonal space heating energy efficiency	η_s	128	%
Declared capacity for space heating at part load and at outdoor temperature T_j				Declared coefficient of performance for space heating at part load and at outdoor temperature T_j			
$T_j = -7\text{ °C}$	Pdh	5.0	kW	$T_j = -7\text{ °C}$	COPd	2.91	-
$T_j = +2\text{ °C}$	Pdh	5.2	kW	$T_j = +2\text{ °C}$	COPd	3.44	-
$T_j = +7\text{ °C}$	Pdh	5.3	kW	$T_j = +7\text{ °C}$	COPd	3.79	-
$T_j = +12\text{ °C}$	Pdh	5.4	kW	$T_j = +12\text{ °C}$	COPd	4.17	-
$T_j = \text{biv}$	Pdh	5.0	kW	$T_j = \text{biv}$	COPd	3.06	-
$T_j = \text{TOL}$	Pdh	4.9	kW	$T_j = \text{TOL}$	COPd	2.71	-
$T_j = -15\text{ °C}$ (if TOL < -20 °C)	Pdh		kW	$T_j = -15\text{ °C}$ (if TOL < -20 °C)	COPd		-
Bivalent temperature	T_{biv}	-5	°C	Min. outdoor air temperature	TOL	-10	°C
Cycling interval capacity	P _{psych}		kW	Cycling interval efficiency	COP _{psych}		-
Degradation coefficient	Cdh	1.00	-	Max supply temperature	WTOL	63	°C
<i>Power consumption in modes other than active mode</i>				<i>Additional heat</i>			
Off mode	P _{OFF}	0.003	kW	Rated heat output	P _{sup}	1.3	kW
Thermostat-off mode	P _{TO}	0	kW	Type of energy input Electric			
Standby mode	P _{SB}	0.007	kW				
Crankcase heater mode	P _{CK}	0.014	kW				
<i>Other items</i>							
Capacity control	Fixed			Rated airflow (air-water)			m ³ /h
Sound power level, indoors/outdoors	L _{WA}	43 / -	dB	Nominal heating medium flow		0.54	m ³ /h
Annual energy consumption	Q _{HE}	3,757	kWh	Brine flow brine-water or water-water heat pumps		0.92	m ³ /h
<i>For heat pump combination heater</i>							
Declared load profile for water heating	XL			Water heating energy efficiency	η_{wh}	91	%
Daily energy consumption	Q _{elec}	8.37	kWh	Daily fuel consumption	Q _{fuel}		kWh
Annual energy consumption	AEC	1,838	kWh	Annual fuel consumption	AFC		GJ
Contact information	NIBE Energy Systems – Box 14 – Hannabadsvägen 5 – 285 21 Markaryd – Sweden						

<i>Model</i>				<i>F1226-8 3x400V</i>			
Type of heat pump	<input type="checkbox"/> Air-water <input type="checkbox"/> Exhaust-water <input checked="" type="checkbox"/> Brine-water <input type="checkbox"/> Water-water						
Low-temperature heat pump	<input type="checkbox"/> Yes <input checked="" type="checkbox"/> No						
Integrated immersion heater for additional heat	<input checked="" type="checkbox"/> Yes <input type="checkbox"/> No						
Heat pump combination heater	<input checked="" type="checkbox"/> Yes <input type="checkbox"/> No						
Climate	<input checked="" type="checkbox"/> Average <input type="checkbox"/> Cold <input type="checkbox"/> Warm						
Temperature application	<input checked="" type="checkbox"/> Average (55 °C) <input type="checkbox"/> Low (35 °C)						
Applied standards	EN-14825 & EN-16147						
Rated heat output	Prated	8,50	kW	Seasonal space heating energy efficiency	η_s	140	%
Declared capacity for space heating at part load and at outdoor temperature T_j				Declared coefficient of performance for space heating at part load and at outdoor temperature T_j			
$T_j = -7\text{ °C}$	Pdh	7.2	kW	$T_j = -7\text{ °C}$	COPd	3.18	-
$T_j = +2\text{ °C}$	Pdh	7.4	kW	$T_j = +2\text{ °C}$	COPd	3.72	-
$T_j = +7\text{ °C}$	Pdh	7.6	kW	$T_j = +7\text{ °C}$	COPd	4.08	-
$T_j = +12\text{ °C}$	Pdh	7.7	kW	$T_j = +12\text{ °C}$	COPd	4.48	-
$T_j = \text{biv}$	Pdh	7.2	kW	$T_j = \text{biv}$	COPd	3.26	-
$T_j = \text{TOL}$	Pdh	7.0	kW	$T_j = \text{TOL}$	COPd	2.97	-
$T_j = -15\text{ °C}$ (if TOL < -20 °C)	Pdh		kW	$T_j = -15\text{ °C}$ (if TOL < -20 °C)	COPd		-
Bivalent temperature	T_{biv}	-6	°C	Min. outdoor air temperature	TOL	-10	°C
Cycling interval capacity	Pcyc		kW	Cycling interval efficiency	COPcyc		-
Degradation coefficient	Cdh	1.00	-	Max supply temperature	WTOL	63	°C
<i>Power consumption in modes other than active mode</i>				<i>Additional heat</i>			
Off mode	P_{OFF}	0.003	kW	Rated heat output	P_{sup}	1.5	kW
Thermostat-off mode	P_{TO}	0.001	kW				
Standby mode	P_{SB}	0.007	kW	Type of energy input	Electric		
Crankcase heater mode	P_{CK}	0.014	kW				
<i>Other items</i>							
Capacity control	Fixed			Rated airflow (air-water)			m ³ /h
Sound power level, indoors/outdoors	L_{WA}	43 / -	dB	Nominal heating medium flow		0.77	m ³ /h
Annual energy consumption	Q_{HE}	4,748	kWh	Brine flow brine-water or water-water heat pumps		1.40	m ³ /h
<i>For heat pump combination heater</i>							
Declared load profile for water heating	XL			Water heating energy efficiency	η_{wh}	93	%
Daily energy consumption	Q_{elec}	8.17	kWh	Daily fuel consumption	Q_{fuel}		kWh
Annual energy consumption	AEC	1,794	kWh	Annual fuel consumption	AFC		GJ
Contact information	NIBE Energy Systems – Box 14 – Hannabadvägen 5 – 285 21 Markaryd – Sweden						

Model				F1226-12 3x400V			
Type of heat pump	<input type="checkbox"/> Air-water <input type="checkbox"/> Exhaust-water <input checked="" type="checkbox"/> Brine-water <input type="checkbox"/> Water-water						
Low-temperature heat pump	<input type="checkbox"/> Yes <input checked="" type="checkbox"/> No						
Integrated immersion heater for additional heat	<input checked="" type="checkbox"/> Yes <input type="checkbox"/> No						
Heat pump combination heater	<input checked="" type="checkbox"/> Yes <input type="checkbox"/> No						
Climate	<input checked="" type="checkbox"/> Average <input type="checkbox"/> Cold <input type="checkbox"/> Warm						
Temperature application	<input checked="" type="checkbox"/> Average (55 °C) <input type="checkbox"/> Low (35 °C)						
Applied standards	EN-14825 & EN-16147						
Rated heat output	Prated	13,0	kW	Seasonal space heating energy efficiency	η_s	133	%
Declared capacity for space heating at part load and at outdoor temperature T_j				Declared coefficient of performance for space heating at part load and at outdoor temperature T_j			
$T_j = -7\text{ °C}$	Pdh	10.5	kW	$T_j = -7\text{ °C}$	COPd	3.11	-
$T_j = +2\text{ °C}$	Pdh	11.0	kW	$T_j = +2\text{ °C}$	COPd	3.57	-
$T_j = +7\text{ °C}$	Pdh	11.2	kW	$T_j = +7\text{ °C}$	COPd	3.87	-
$T_j = +12\text{ °C}$	Pdh	11.5	kW	$T_j = +12\text{ °C}$	COPd	4.13	-
$T_j = \text{biv}$	Pdh	10.6	kW	$T_j = \text{biv}$	COPd	3.22	-
$T_j = \text{TOL}$	Pdh	10.3	kW	$T_j = \text{TOL}$	COPd	2.93	-
$T_j = -15\text{ °C}$ (if TOL < -20 °C)	Pdh		kW	$T_j = -15\text{ °C}$ (if TOL < -20 °C)	COPd		-
Bivalent temperature	T_{biv}	-5.2	°C	Min. outdoor air temperature	TOL	-10	°C
Cycling interval capacity	Pcyc		kW	Cycling interval efficiency	COPcyc		-
Degradation coefficient	Cdh	0.99	-	Max supply temperature	WTOL	63	°C
Power consumption in modes other than active mode				Additional heat			
Off mode	P_{OFF}	0.002	kW	Rated heat output	P_{sup}	2.7	kW
Thermostat-off mode	P_{TO}	0.018	kW				
Standby mode	P_{SB}	0.007	kW	Type of energy input	Electric		
Crankcase heater mode	P_{CK}	0.030	kW				
Other items							
Capacity control	Fixed			Rated airflow (air-water)			m ³ /h
Sound power level, indoors/outdoors	L_{WA}	45 / -	dB	Nominal heating medium flow		1.11	m ³ /h
Annual energy consumption	Q_{HE}	7,628	kWh	Brine flow brine-water or water-water heat pumps		2.04	m ³ /h
For heat pump combination heater							
Declared load profile for water heating	XL			Water heating energy efficiency	η_{wh}	89	%
Daily energy consumption	Q_{elec}	8.54	kWh	Daily fuel consumption	Q_{fuel}		kWh
Annual energy consumption	AEC	1,876	kWh	Annual fuel consumption	AFC		GJ
Contact information	NIBE Energy Systems – Box 14 – Hannabadvägen 5 – 285 21 Markaryd – Sweden						

Electrical circuit diagram

3X400 V 6-12 KW

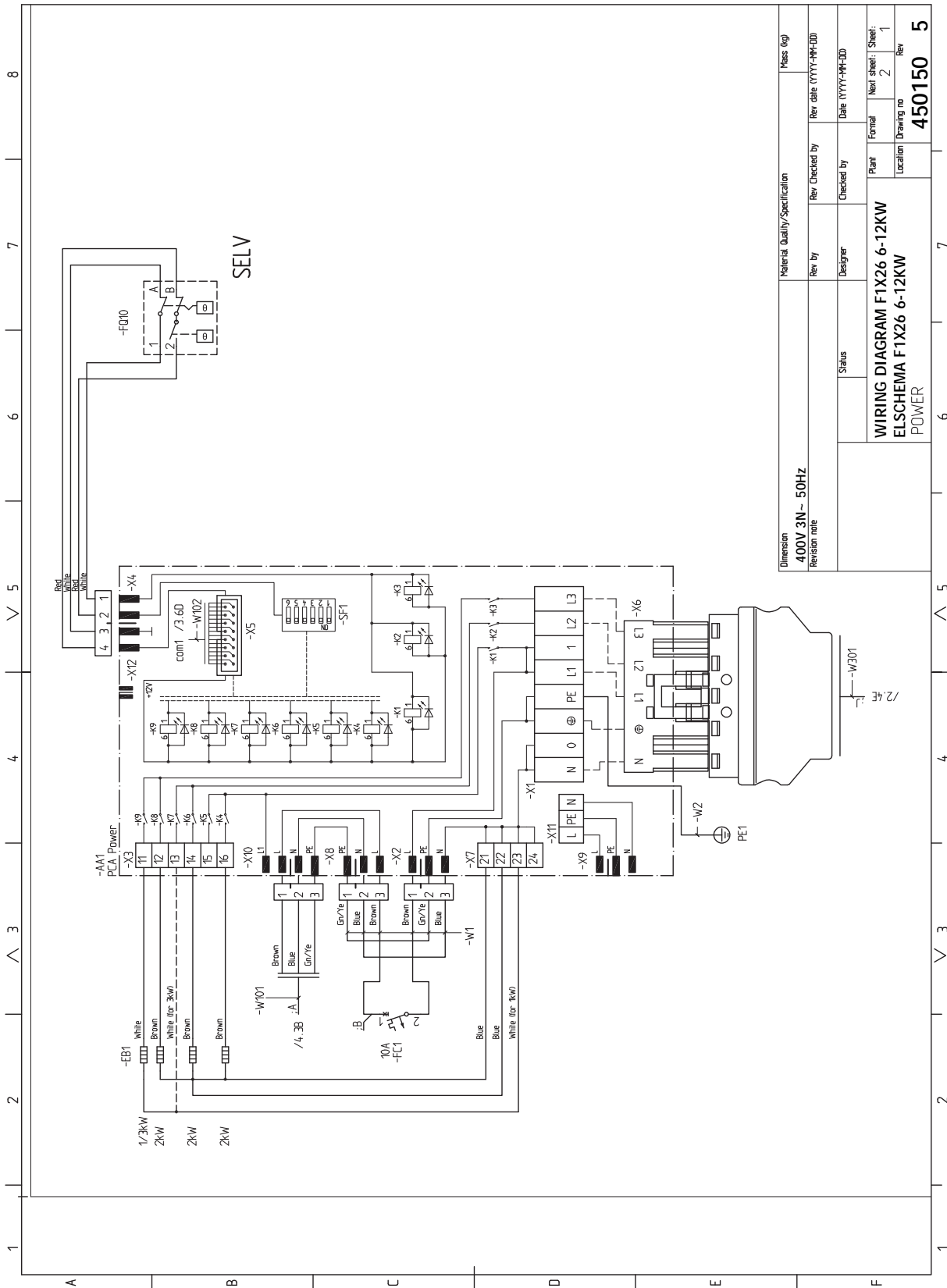

Dimension	Material Quality/Specification	Mass (kg)
400V 3N ~ 50HZ		
Revision table	Rev. by	Rev. date (YYYY-MM-DD)
	Designer	Date (YYYY-MM-DD)
	Status	Plant
		Location
		Formal
		Rev. sheet: 2
		Sheet: 1
		Drawing no
		450150
		Rev
		5

WIRING DIAGRAM F1X26 6-12KW
ELSCHEMA F1X26 6-12KW
POWER

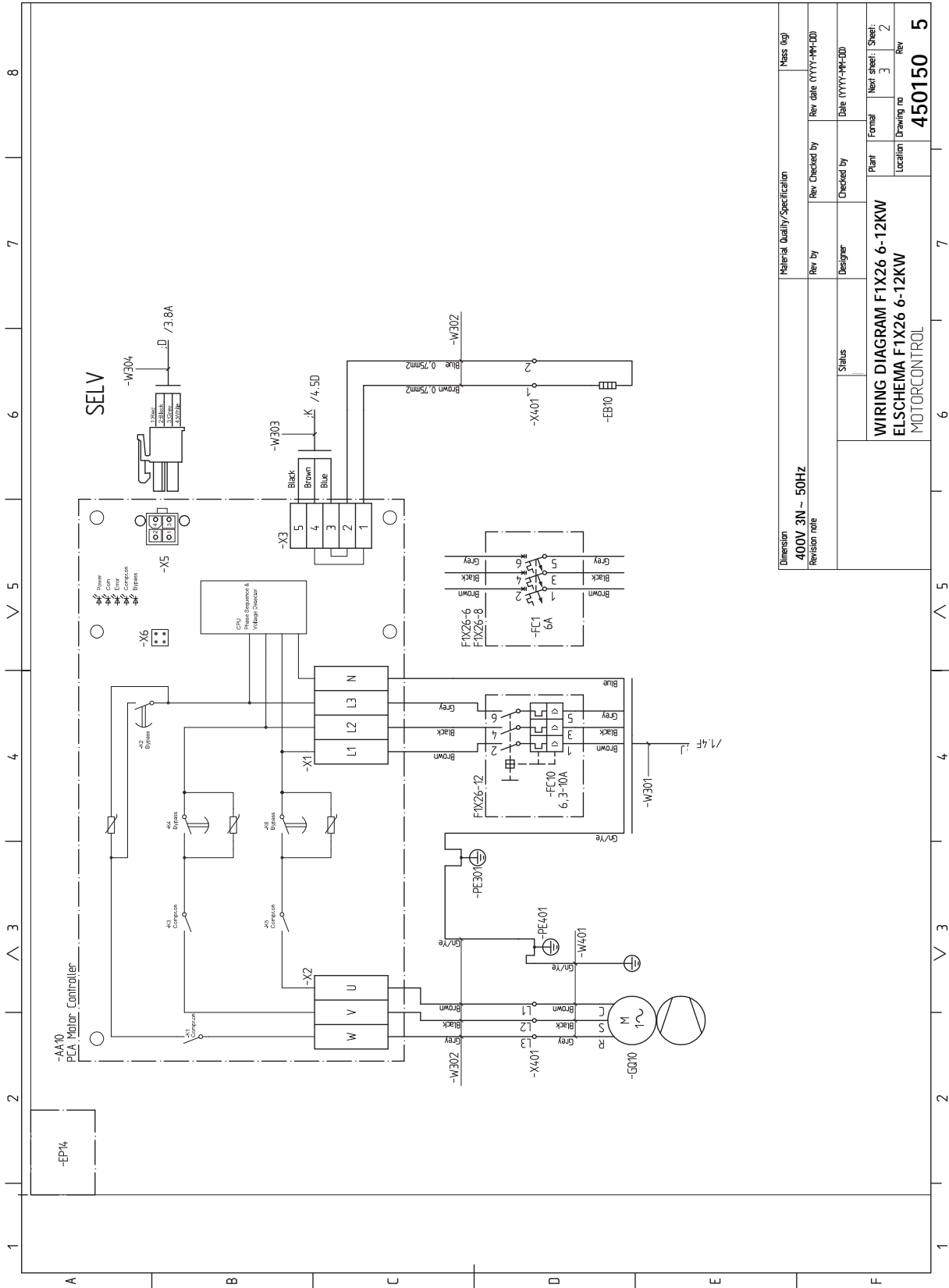

Dimension		Material Quality/Specification		Mass (kg)	
400V 3N ~ 50Hz		Rev by		Rev table (YYYY-MM-DD)	
Revision note		Designer		Date (YYYY-MM-DD)	
Status		Checked by		Plant	
WIRING DIAGRAM F1X26 6-12KW		WIRING DIAGRAM F1X26 6-12KW		Formal	
MOTORCONTROL		MOTORCONTROL		Next sheet: Sheet:	
				3 2	
				Drawing no	
				Rev	
				450150	
				5	

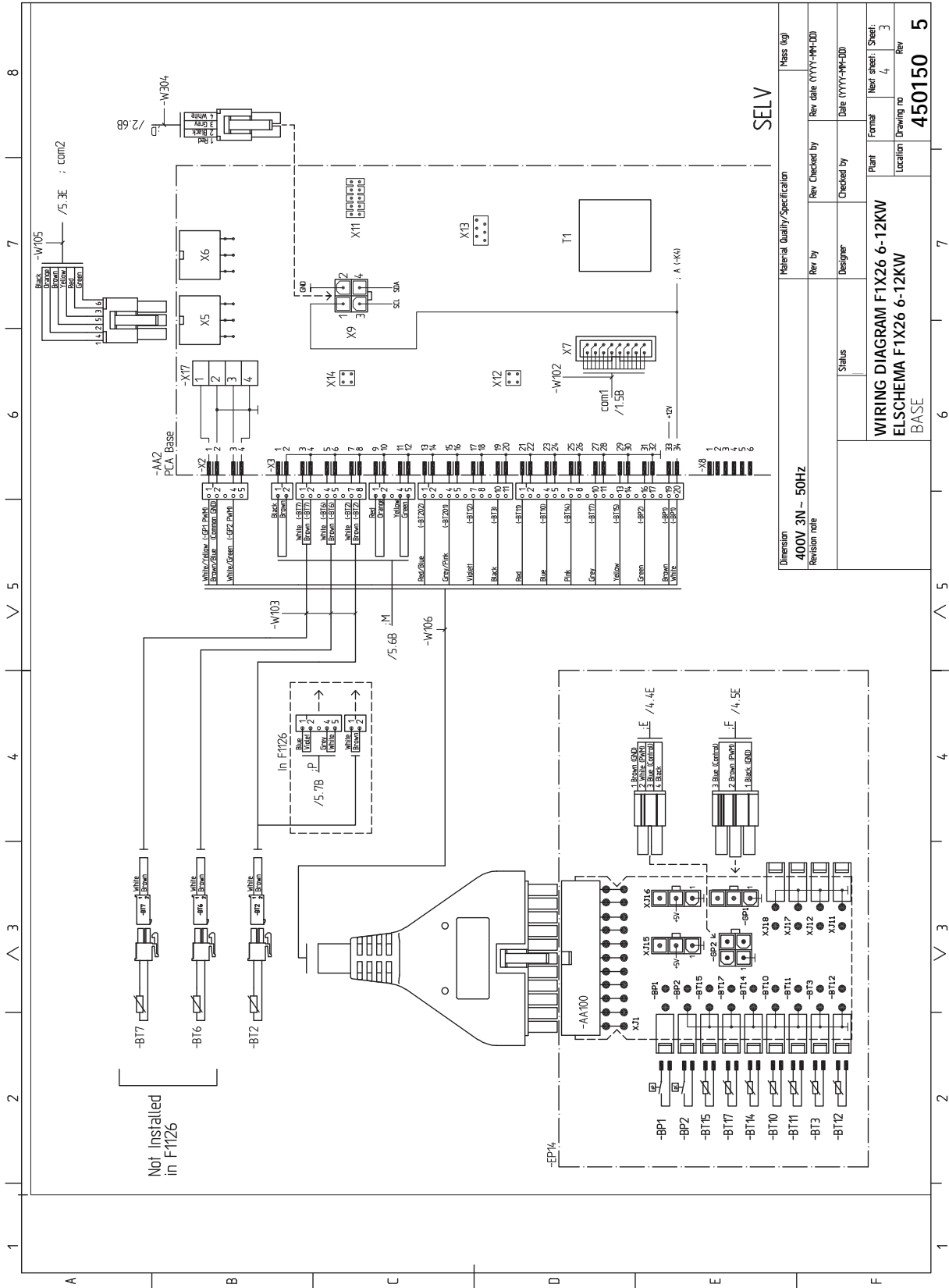

Material Quality/Specification		Mass (kg)	
Rev by	Rev Checked by	Rev Table (YYYY-MM-DD)	Rev (YYYY-MM-DD)
Designer	Checked by	Date (YYYY-MM-DD)	
Status			
Plant	Formal	Next sheet	Sheet
Location		Drawing no	Rev
		450150	5

WIRING DIAGRAM F1X26 6-12KW
 ELS SCHEMA F1X26 6-12KW
 BASE

1 2 3 4 5 6 7 8

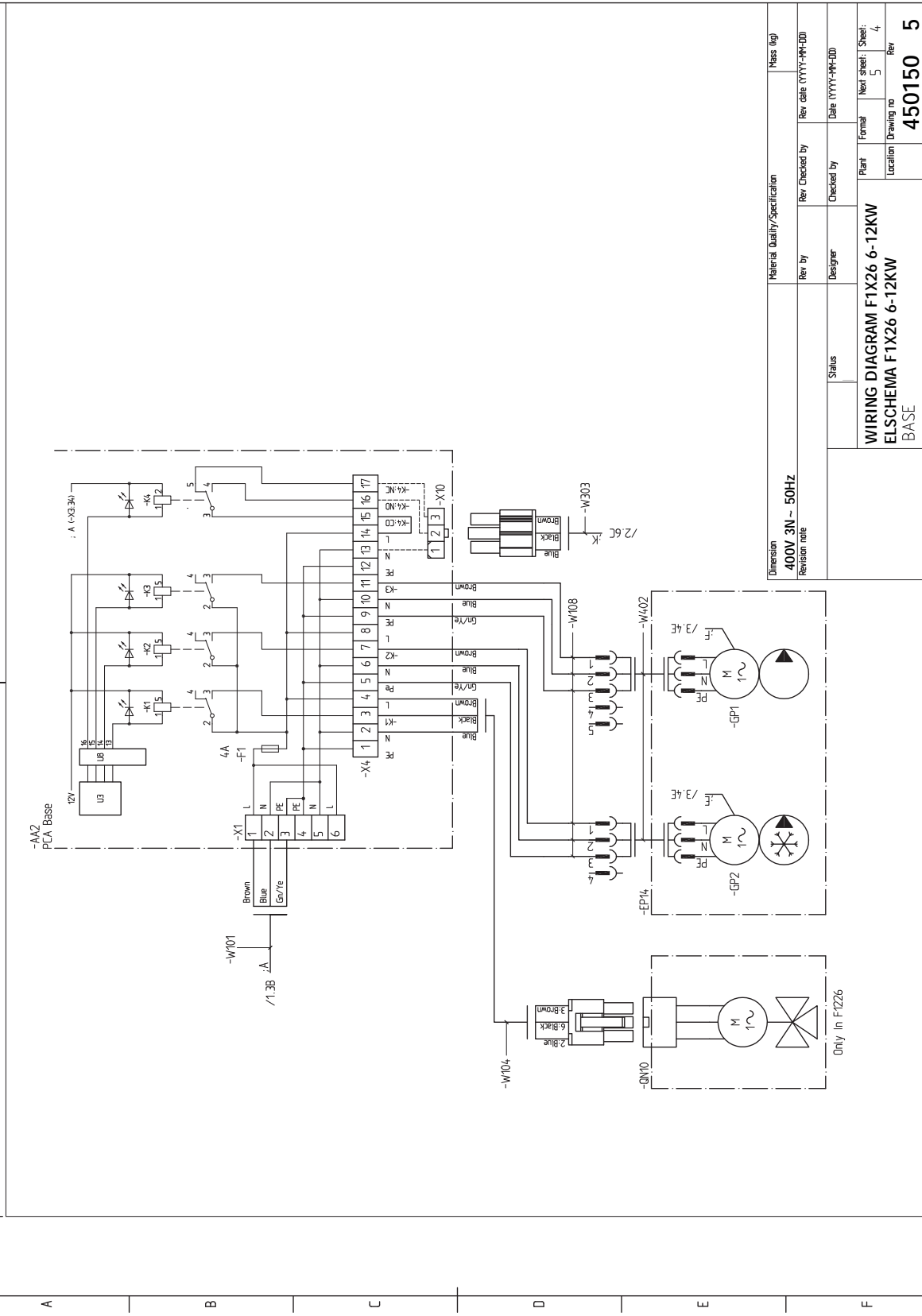

Dimension	Material Quality/Specification	Mass (kg)
400V 3N ~ 50HZ	Rev by	Rev table (YYYY-MM-DD)
Revision note	Designer	Date (YYYY-MM-DD)
	Status	Checked by
	Plant	Formal
	Location	Next sheet: Sheet:
		Drawing no
		Rev
		450150
		5
		4
		5
		4
		5
		4
		5

WIRING DIAGRAM F1X26 6-12KW
ELSCHEMA F1X26 6-12KW
BASE

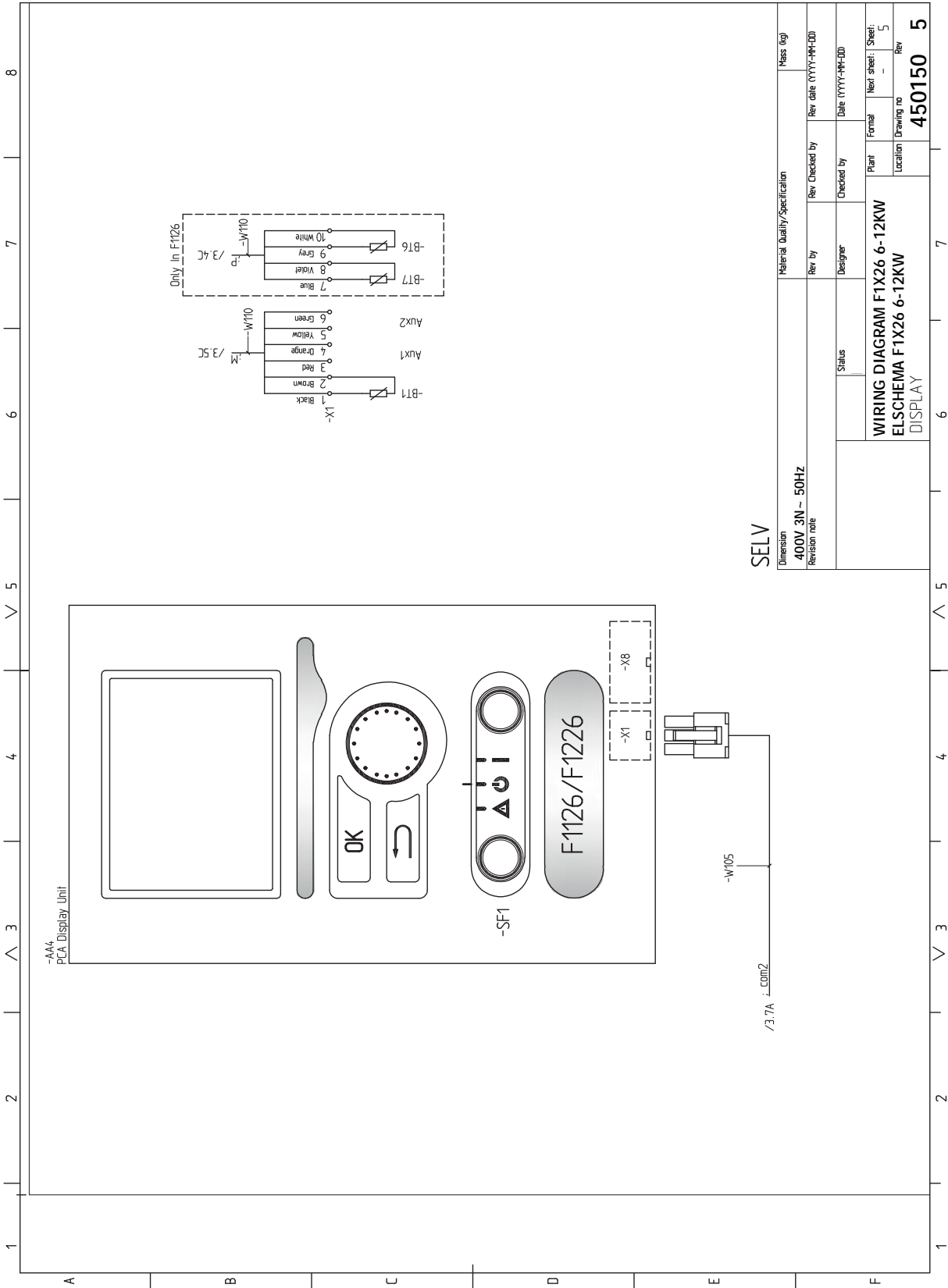

SELV

Dimension	Material Quality/Specification		Mass (kg)
400V 3N ~ 50Hz	Rev by	Rev Checked by	Rev table (YYYY-MM-DD)
Revision note	Designer	Checked by	Date (YYYY-MM-DD)
	Status	Plant	Formal
		Location	Next sheet: Sheet: 5
			Drawing no
			Rev
			450150
			5

Item register

- A**
- Accessibility, electrical connection, 21
- Accessories, 51
- Alarm, 48
- Assembly, 7
- B**
- Back button, 32
- Brine side, 17
- C**
- Cable lock, 22
- Cold and hot water, 18
 - Connecting cold and hot water, 18
- Commissioning and adjusting, 27
 - Filling and venting, 27
 - Post adjustment and bleeding, 29
 - Preparations, 27
 - Start guide, 28
- Connecting accessories, 26
- Connecting external operating voltage for the control system, 23
- Connecting the climate system, 17
- Connections, 22
- Control, 32, 36
 - Control - Introduction, 32
 - Control - Menus, 36
- Control - Introduction, 32
 - Display unit, 32
 - Menu system, 33
- Control knob, 32
- Control - Menus, 36
 - Menu 5 - SERVICE, 38
- Cooling section, 13
- D**
- Data for energy efficiency of the system, 56
- Delivery and handling, 7
 - Assembly, 7
 - Drawing out the cooling module, 7
 - Installation area, 7
 - Removing parts of the insulation, 9
 - Removing the covers, 8
 - Supplied components, 8
 - Transport, 7
- Dimensions and pipe connections, 16
- Dimensions and setting-out coordinates, 52
- Display, 32
- Display unit, 32
 - Back button, 32
 - Control knob, 32
 - Display, 32
 - OK button, 32
 - Status lamp, 32
 - Switch, 32
- Disturbances in comfort, 48
 - Alarm, 48
 - Manage alarm, 48
 - Troubleshooting, 48
- Docking alternatives, 18
 - Free cooling, 19
 - Ground water system, 18
 - Neutralization vessel, 18
 - Pool, 19
 - Under floor heating systems, 19
 - Ventilation recovery, 19
- Draining the climate system, 42
- Draining the hot water heater, 42
- Drawing out the cooling module, 7, 44
- E**
- Electrical addition - maximum output, 23
 - Setting max electrical output, 23
 - Switching to maximum electrical output, 24
- Electrical cabinets, 12
- Electrical circuit diagram, 60
- Electrical connections, 20
 - Accessibility, electrical connection, 21
 - Cable lock, 22
 - Connecting accessories, 26
 - Connecting external operating voltage for the control system, 23
 - Connections, 22
 - Electrical addition - maximum output, 23
 - External connection options, 25
 - General, 20
 - Miniature circuit-breaker, 20
 - Motor cut-out, 21
 - Optional connections, 25
 - Outdoor sensor, 23
 - Power connection, 22
 - Removing the cover, base board, 22
 - Removing the cover, immersion heater circuit board, 21
 - Removing the hatch, input circuit board, 21
 - Settings, 23

- Standby mode, 24
- Temperature limiter, 20
- Emptying the brine system, 43
- Energy labelling, 56
 - Data for energy efficiency of the package, 56
 - Information sheet, 56
 - Technical documentation, 57
- External connection options, 25
 - Possible selection for AUX inputs, 25

F

- Filling and venting, 27
 - Filling and venting the brine system, 27
 - Filling and venting the climate system, 27
 - Filling the hot water heater, 27
- Filling and venting the brine system, 27
- Filling and venting the climate system, 27
- Filling the hot water heater, 27

H

- Heating medium side, 17
 - Connecting the climate system, 17
- Helping the circulation pump to start, 43
- Help menu, 35

I

- Important information, 4
 - Recovery, 5
- Information sheet, 56
- Inspection of the installation, 6
- Installation alternative
 - Water heater with immersion heater, 18
- Installation area, 7

M

- Manage alarm, 48
- Marking, 4
- Menu 5 - SERVICE, 38
- Menu system, 33
 - Help menu, 35
 - Operation, 34
 - Scroll through the windows, 35
 - Selecting menu, 34
 - Selecting options, 34
 - Setting a value, 34
- Miniature circuit-breaker, 20
- Motor cut-out, 21

O

- OK button, 32
- Operation, 34
- Optional connections, 25
- Outdoor sensor, 23

P

- Pipe connections, 15
 - Brine side, 17
 - Cold and hot water
 - Connecting cold and hot water, 18
 - Dimensions and pipe connections, 16
 - Docking alternatives, 18
 - General, 15

- Heating medium side, 17

- Pipe dimensions, 16

- Symbol key, 15

- System diagram, 16

- Pipe dimensions, 16

- Possible selection for AUX inputs, 25

- Post adjustment and bleeding, 29

- Pump adjustment, 29

- Pump capacity diagrams, collector side, 29

- Readjusting, venting, heat medium side, 30

- Power connection, 22

- Preparations, 27

- Pump adjustment, 29

- Heating medium side, 29

- Pump capacity diagrams, collector side, 29

R

- Readjusting, venting, heat medium side, 30

- Remove parts of the insulation, 9

- Removing the cover, base board, 22

- Removing the cover, immersion heater circuit board, 21

- Removing the covers, 8

- Removing the hatch, input circuit board, 21

S

- Safety information

- Inspection of the installation, 6

- Marking, 4

- Serial number, 5

- Symbols, 4

- Scroll through the windows, 35

- Selecting menu, 34

- Selecting options, 34

- Serial number, 5

- Service, 42

- Service actions, 42

- Service actions, 42

- Draining the climate system, 42

- Draining the hot water heater, 42

- Drawing out the cooling module, 44

- Emptying the brine system, 43

- Helping the circulation pump to start, 43

- Standby mode, 42

- Temperature sensor data, 44

- USB service outlet, 45

- Setting a value, 34

- Settings, 23

- Standby mode, 42

- Power in emergency mode, 24

- Start guide, 28

- Status lamp, 32

- Supplied components, 8

- Switch, 32

- Symbol key, 15

- Symbols, 4

- System diagram, 16

T

- Technical data, 52

- Dimensions and setting-out coordinates, 52

- Electrical circuit diagram, 60

- Energy labelling, 56
 - Data for energy efficiency of the system, 56
 - Information sheet, 56
 - Technical documentation, 57
- Technical Data, 54
- Technical Data, 54
 - Working range heat pump, 55
- Technical documentation, 57
- Temperature limiter, 20
 - Resetting, 20
- Temperature sensor data, 44
- The heat pump design, 10
 - Component list cooling section, 13
 - Component list electrical cabinets, 12
 - Component location cooling section, 13
 - Component location electrical cabinets, 12
 - Component locations, 10
 - List of components, 10
- Transport, 7
- Troubleshooting, 48
- U**
- USB service outlet, 45
- W**
- Wiring diagram
 - 3x400V 6-12 kW, 60
- Working range heat pump, 55

Contact information

AUSTRIA

KNV Energietechnik GmbH
Gahberggasse 11, 4861 Schörfling
Tel: +43 (0)7662 8963-0
mail@knv.at
knv.at

CZECH REPUBLIC

Družstevní závody Dražice - strojírna
s.r.o.
Dražice 69, 29471 Benátky n. Jiz.
Tel: +420 326 373 801
nibe@nibe.cz
nibe.cz

DENMARK

Vølund Varmeteknik A/S
Industrivej Nord 7B, 7400 Herning
Tel: +45 97 17 20 33
info@volundvt.dk
volundvt.dk

FINLAND

NIBE Energy Systems Oy
Juurakkotie 3, 01510 Vantaa
Tel: +358 (0)9 274 6970
info@nibe.fi
nibe.fi

FRANCE

NIBE Energy Systems France SAS
Zone industrielle RD 28
Rue du Pou du Ciel, 01600 Reyrieux
Tél: 04 74 00 92 92
info@nibe.fr
nibe.fr

GERMANY

NIBE Systemtechnik GmbH
Am Reiherpfahl 3, 29223 Celle
Tel: +49 (0)5141 75 46 -0
info@nibe.de
nibe.de

GREAT BRITAIN

NIBE Energy Systems Ltd
3C Broom Business Park,
Bridge Way, S41 9QG Chesterfield
Tel: +44 (0)845 095 1200
info@nibe.co.uk
nibe.co.uk

NETHERLANDS

NIBE Energietechnik B.V.
Energieweg 31, 4906 CG Oosterhout
Tel: +31 (0)168 47 77 22
info@nibenl.nl
nibenl.nl

NORWAY

ABK-Qviller AS
Brobekkveien 80, 0582 Oslo
Tel: (+47) 23 17 05 20
post@abkqviller.no
nibe.no

POLAND

NIBE-BIAWAR Sp. z o.o.
Al. Jana Pawla II 57, 15-703 Bialystok
Tel: +48 (0)85 66 28 490
biawar.com.pl

RUSSIA

EVAN
bld. 8, Yuliusa Fuchika str.
603024 Nizhny Novgorod
Tel: +7 831 419 57 06
kuzmin@evan.ru
nibe-evan.ru

SWEDEN

NIBE Energy Systems
Box 14
Hannabadsvägen 5, 285 21 Markaryd
Tel: +46 (0)433-27 3000
info@nibe.se
nibe.se

SWITZERLAND

NIBE Wärmetechnik c/o ait Schweiz
AG
Industriepark, CH-6246 Altishofen
Tel. +41 (0)58 252 21 00
info@nibe.ch
nibe.ch

For countries not mentioned in this list, contact NIBE Sweden or check nibe.eu for more information.

NIBE Energy Systems
Hannabadsvägen 5
Box 14
SE-285 21 Markaryd
info@nibe.se
nibe.eu

IHB EN 2008-1 531739

This manual is a publication from NIBE Energy Systems. All product illustrations, facts and data are based on the available information at the time of the publication's approval. NIBE Energy Systems makes reservations for any factual or printing errors in this manual.

©2020 NIBE ENERGY SYSTEMS

