

Transformers Flexible and Reliable



Powering Business Worldwide

The right winding for every application



Control, Isolation and Safety transformers Multi-winding transformers



Eaton offers a wide range of control transformers. All transformers are designed and tested according to the requirements of the IEC/EN 61558. This means that, depending on the specific type, they can be used in accordance with international installation standard IEC/EN 60204.

We also offer matching, matching transformer and power transformer transformers upon request.

Additionally, Eaton offers a vast selection of transformers approved for machine and system exports to north america.

Besides their use for voltage adjustment, transformers can also be used to change network configuration.

Information relevant for export to North America



Product Standards	UL 506; UL5085-1; UL 5085-2; CSA-C22.2 No. 66; CSA-C22.2 No. 66.1-06; CSA-C22.2 No. 66.2-06; IEC/EN 61558-2-2; CE marking
UL File No.	E167225 XPTQ2,
ULCCN	XPTQ8
CSA File No.	UL report applies to both US and Canada
CSA Class No.	–
NA Certification	UL Recognized, certified by UL for USA & Canada
Suitable for	Canada Branchcircuits
Max. Voltage Rating	600 V AC
Degree of Protection	IEC: IP00, UL/CSA Type: –

Transformers: Easy to use, reliable in performance.

All Eaton transformers apply to the IEC 85 and IEC 216 according to insulation class B. This ensures a highly reliable operation temperature of 130°C. Additionally, all our transformers are compliant to IP00 degree of protection and an ambient air temperature of -25° to +40°C without derating.

A resin impregnation avoids corrosion to the transformers, improves heat emission and notably reduces humming. Eaton offers a tropical protection lacquer for challenging application areas, which provides additional protection from humidity and corrosion.

Control transformers STN

Our single purpose STN control transformers provide a reliable operational voltage for control and auxiliary circuits at any time.

Due to the easy commissioning and construction according to IEC/EN 61558-2-2, VDE 0570-2-, UL 5085-2 and CSA 22.2 No. 66, the STN control transformers are extremely reliable and grant maximum security to equipment and systems.

Multi-winding transformers UTI

Eaton's multi-winding transformers are the most adaptive ones of their kind and thanks to their substantial approvals optimal for worldwide application.

Control, isolating and safety transformers STI, STZ, DTZ

The control, isolation and safety transformers STI, STZ and DTZ are built and audited according to IEC/EN 61558-2-2/2-4/2-6, UL 5085-2 and CSA 22.2 No. 66 norms.

The transformer reduces the effects of shortcircuits and guarantees safe electrical disconnection in case of failure.

Typical areas of application are among others actuating circuit, protective separation, PELV-circuit (protective small voltage) and FELV-circuit (functional low voltage).



Single-phase control, isolation and safety transformer



Three-phase control, isolation and safety transformer



Single-phase control transformer



Single-phase multi-winding transformer

	Single-phase transformers				Three-phase transformers
	STN	STZ	STI	UTI	DTZ
Control transformer	X	X	X	X	X
Isolating transformer	-	X	X	X	X
Safety transformer	-	X	X	X	X
Multi-winding transformer	-	-	-	X	-
Preferred voltages	X	-	X	-	-
Selectable Voltages	X	X	-	-	X
Equipment*					
Housing IP23	-	X	-	-	X
Screen winding	-	X	-	-	X
Inrush current limiters	-	X	X	-	-
Additional tappings	-	X	-	-	X
Additional windings					
Secondary side	-	X	-	-	-
Primary side	-	Please enquire	-	-	-
Approvals					
UL/CSA	up to 4 kVA	up to 4 kVA	up to 4 kVA	X	up to 6.3 kVA
DNV & Germanische Lloyd	Please enquire	Please enquire	Please enquire	Please enquire	Please enquire

* Accessories available at Eaton.com/control-power-transformers

Single-phase control transformers with preferred voltages STN– Never compromising security

	Rated power		Preferred voltage 400/230V		Preferred voltage 400/24V		Preferred voltage 230/24V		Preferred voltage 230/230V	
	kVA	Short-time rating kVA	Type	Article no.	Type	Article no.	Type	Article no.	Type	Article no.
 <p>IEC/EN 61558-2-2 VDE 0570 Teil 2-2 Rated input voltage 230 ± 5 % V, 400 ± 5 % V Rated output voltage 24 V, 230 V</p>	0.06	0.095	STN0,06(400/230)	204936	STN0,06(400/24)	204937	STN0,06(230/24)	204935	STN0,06(230/230)	204934
	0.1	0.16	STN0,1(400/230)	204942	STN0,1(400/24)	204943	STN0,1(230/24)	204941	STN0,1(230/230)	204940
	0.16	0.32	STN0,16(400/230)	204948	STN0,16(400/24)	204949	STN0,16(230/24)	204947	STN0,16(230/230)	204945
	0.2	0.38	STN0,2(400/230)	204977	STN0,2(400/24)	204978	STN0,2(230/24)	204976	STN0,2(230/230)	204951
	0.25	0.44	STN0,25(400/230)	204980	STN0,25(400/24)	221509	STN0,25(230/24)	221508		
	0.315	0.6	STN0,315(400/230)	204982	STN0,315(400/24)	221511	STN0,315(230/24)	221510		
	0.4	0.62	STN0,4(400/230)	204984	STN0,4(400/24)	221514	STN0,4(230/24)	221513		
	0.5	0.88	STN0,5(400/230)	204986	STN0,5(400/24)	221516	STN0,5(230/24)	221515		
	0.63	1.51	STN0,63(400/230)	204988	STN0,63(400/24)	221518	STN0,63(230/24)	221517		
	0.8	2.25	STN0,8(400/230)	204990	STN0,8(400/24)	221520	STN0,8(230/24)	221519		
	1	3.28	STN1,0(400/230)	204992	STN1,0(400/24)	221522	STN1,0(230/24)	221521		
	1.3	4.8	STN1,3(400/230)	221523						
	1.6	3.98	STN1,6(400/230)	221524						
	2	5.75	STN2,0(400/230)	221525						
	2.5	7.24	STN2,5(400/230)	221526						
	3	8.36	STN3,0(400/230)	221527						
4	12.2	STN4,0(400/230)	221528							

Just select - for example your voltage

Single-phase control transformer with selectable voltage

	Rated power		Short-time rating		Type	Article no.
	kVA	Short-time rating kVA	kVA	Short-time rating kVA		
 <p>IEC/EN 61558-2-2 VDE 0570 Teil 2-2 Rated input voltage 100 – 690 ± 5 % V, Rated output voltage 12 – 250 V</p>	0.06	0.095	0.06	0.095	STN0,06(*/*)	204938
	0.1	0.16	0.1	0.16	STN0,1(*/*)	204939
	0.16	0.32	0.16	0.32	STN0,16(*/*)	204944
	0.2	0.38	0.2	0.38	STN0,2(*/*)	204950
	0.25	0.44	0.25	0.44	STN0,25(*/*)	204979
	0.315	0.6	0.315	0.6	STN0,315(*/*)	204981
	0.4	0.62	0.4	0.62	STN0,4(*/*)	204983
	0.5	0.88	0.5	0.88	STN0,5(*/*)	204985
	0.63	1.51	0.63	1.51	STN0,63(*/*)	204987
	0.8	2.25	0.8	2.25	STN0,8(*/*)	204989
	1	3.28	1	3.28	STN1,0(*/*)	204991
	1.3	4.8	1.3	4.8	STN1,3(*/*)	204993
	1.6	3.98	1.6	3.98	STN1,6(*/*)	204994
	2	5.75	2	5.75	STN2,0(*/*)	204995
	2.5	7.24	2.5	7.24	STN2,5(*/*)	204996
	3	8.36	3	8.36	STN3,0(*/*)	204997
4	12.2	4	12.2	STN4,0(*/*)	204998	

Ordering example

When ordering, the type reference must include the following details:

STN0, 1(*/*)

- Wildcard * = Rated input voltage
- Wildcard * = Rated output voltage
 - Desired type STN0, 1
 - Desired rated input voltage 200 V
 - Desired rated output voltage 18.5 V

The correct type is

STN0,1(200/18.5)

Dimension

Single-phase control transformer

STN0,6...2,0

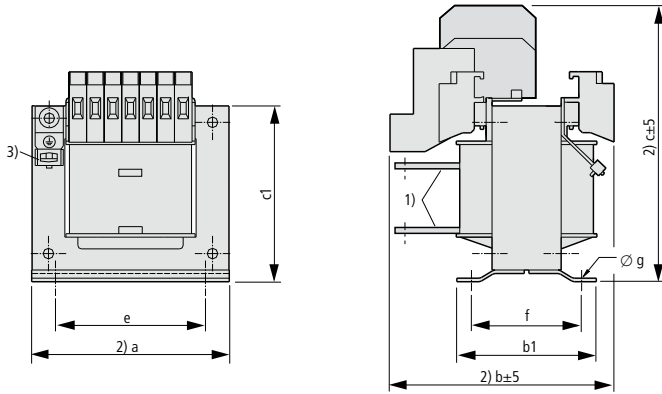

- ① Connection lugs
- ② Maximum space requirement
- ③ with STN0,6...2,0 ground connection at bottom

Type	Total Weight kg	Off-load losses W	Short-circuit voltage W	Short-circuit voltage V	Efficiency %	a	b	c	b	c	b	c	b	c	b	c	e	f	Ø g	b1	c1
						12 V	24 V	42 V	110 V	230 V											
STN0,06	1	7	10	11	0.79	66	80	80	80	80	80	80	80	80	79	78	50	56	4,8x8	67	60
STN0,1	1.5	7	15	10	0.84	85	75	93	75	93	75	93	75	93	75	93	64	47	4,8x8	60	76
STN0,16	2.4	11	16	6.7	0.87	85	97	93	97	93	97	93	97	93	97	93	64	70	4,8x8	83	76
STN0,2	2.8	9	19	6.8	0.88	106	83	111	83	111	83	111	83	111	83	111	80	61	5,8x12	80	97
STN0,25	2.9	9	21	6.3	0.9	106	100	115	83	111	83	111	83	111	83	111	80	61	5,8x12	80	97
STN0,315	3.5	11	21	5.3	0.91	106	108	115	92	111	92	111	92	111	92	111	80	70	5,8x12	89	97
STN0,4	4.2	12	27	5.3	0.92	121	104	125	88	121	88	121	88	121	88	121	90	68	5,8x12	86	106
STN0,5	5.1	15	27	4.1	0.93	121	116	125	116	125	100	121	100	121	100	121	90	80	5,8x12	98	106
STN0,63	7.1	21	32	3.8	0.93	151	118	149	118	149	107	145	107	145	107	145	122	82	7x15	104	132
STN0,8	9.8	24	24	2.5	0.94	151	124	202	135	149	124	145	124	145	124	145	122	99	7x15	121	132
STN1,0	12.4	33	26	2.2	0.94	151	150	202	161	149	161	149	150	145	150	145	122	125	7x15	147	132
STN1,3	14.1	46	33	2.1	0.94	175	138	225	145	164	145	164	138	160	138	160	135	110	7x15	135	152
STN1,6	14.3	43	44	2.5	0.95	175	183	160	138	225	145	164	138	160	138	160	135	110	7x15	135	152
STN2,0	19.9	56	42	2	0.95	175	213	160	168	225	175	164	168	160	168	160	135	140	7x15	165	152

Measurements in mm

STN2,5...4,0

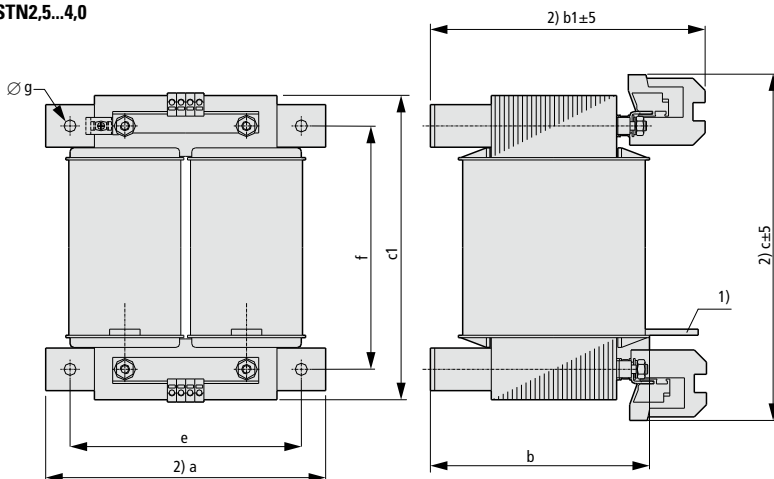

- ① Connection lugs
- ② Maximum space requirement

Type	Total Weight kg	Off-load losses W	Short-circuit losses W	Short-circuit voltage V	Efficiency %	a	b	c1	e	f	Ø g	12 V	12 V	24 V	24 V	42 V	42 V	110 V	110 V	230 V	230 V
						b1	c	b1	c	b1	c	b1	c	b1	c	b1	c	b1	c	b1	c
STN2,5	20	21	145	2.4	0.95	230	127	250	190	200	11	177	253	177	253	206	264	154	274	150	257
STN3,0	23	32	94	2.4	0.95	230	152	250	190	200	11	202	253	202	253	231	264	179	274	175	257
STN4,0	27	28	143	2.4	0.95	230	167	250	190	200	11	225	260	245	250	245	255	200	275	185	255

Measurements in mm

Single-phase control, isolation and safety transformers STZ



IEC/EN 61558-2-2/2-4/2-6
VDE 0570 Part 2-2,
Part 2-6 (Safety transformers),
Part 2-4 (Isolating transformers)
Rated input voltage 50 – 950 ± 5 % V,
Rated output voltage 12 – 1000 V

Ordering example

When ordering, the type reference must include the following details:

STZ0,06(*/*)

1. Wildcard *= Rated input voltage
2. Wildcard *= Rated output voltage
 - desired type STZ0,06
 - desired rated input voltage
 - desired rated output voltage

The correct type is

STZ0,06(230/12)

Attention!

Preferred voltage 400/230 V, 400/24 V, 230/230 V, 230/24 V.
230/24 V are delivered as STI only, if there were no additional options in the order, e.g. shielding winding.

Rated power	Short-time rating	Type	Article no.
kVA	kVA		
0.06	0.13	STZ0,06(*/*)	914761
0.1	0.24	STZ0,1(*/*)	914762
0.16	0.36	STZ0,16(*/*)	914763
0.2	0.44	STZ0,2(*/*)	914764
0.25	0.6	STZ0,25(*/*)	914765
0.315	0.75	STZ0,315(*/*)	914766
0.4	1.1	STZ0,4(*/*)	914767
0.5	1.6	STZ0,5(*/*)	914768
0.63	1.7	STZ0,63(*/*)	914769
0.8	2	STZ0,8(*/*)	914770
1	2.8	STZ1,0(*/*)	914771
1.3	3.7	STZ1,3(*/*)	914772
1.6	5.5	STZ1,6(*/*)	914773
2	7	STZ2,0(*/*)	914774
2.5	9	STZ2,5(*/*)	914775
3	11.5	STZ3(*/*)	914776
4	15	STZ4,0(*/*)	914777
5.3	13	STZ5,3(*/*)	201060
8.3	21	STZ8,3(*/*)	201062
13.3	34	STZ13,3(*/*)	201064

Three-phase control, isolating and safety transformers DTZ



IEC/EN 61558-2-2/2-4/2-6
VDE 0570 Part 2-2,
Part 2-6 (Safety transformers),
Part 2-4 (Isolating transformer)
Rated input voltage 50 – 950 ± 5 % V,
Rated output voltage 18.5 – 1000 V

Ordering example

When ordering, the type reference must include the following details:

DTZ0,1(*/*)

1. Wildcard *= Rated input voltage
2. Wildcard *= Rated output voltage
 - desired type DTZ0,1
 - desired rated input voltage
 - desired rated output voltage

The correct type is

DTZ0,1(200/18,5)DY(N)5

Rated power	Short-time rating	Type	Article no.
kVA	kVA		
0.1	0.2	DTZ0,1(*/*)*	914799
0.16	0.32	DTZ0,16(*/*)*	914800
0.25	0.5	DTZ0,25(*/*)*	914801
0.4	0.8	DTZ0,4(*/*)*	914802
0.5	1	DTZ0,5(*/*)*	914803
0.63	1.38	DTZ0,63(*/*)*	914804
1	2.2	DTZ1,0(*/*)*	914805
1.6	3.5	DTZ1,6(*/*)*	914806
2	4.4	DTZ2,0(*/*)*	914807
2.5	5.5	DTZ2,5(*/*)*	914808
4	6.2	DTZ4,0(*/*)*	914809
6.3	15.7	DTZ6,3(*/*)*	914810
8	20	DTZ8,0(*/*)*	914811
10	25	DTZ10(*/*)*	914812
12.5	31	DTZ12,5(*/*)*	914813
16	40	DTZ16(*/*)*	914814
20	50	DTZ20(*/*)*	914815
25	62	DTZ25(*/*)*	914816

Dimension

Single-phase control-isolation-/safety transformers STZ

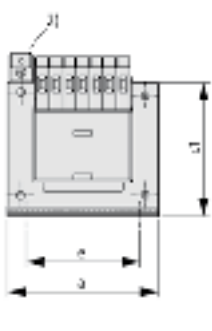

Fig. 1

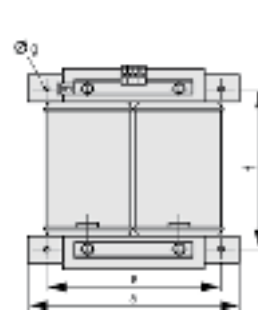
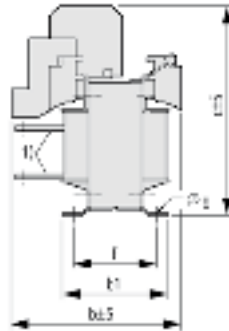

Fig. 2

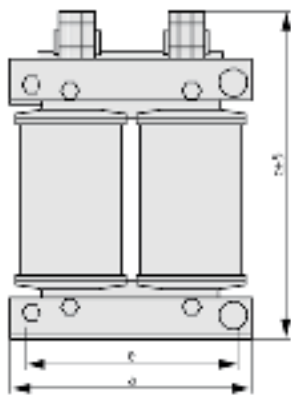
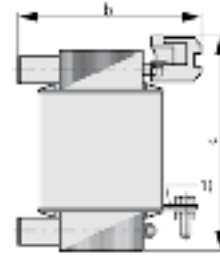
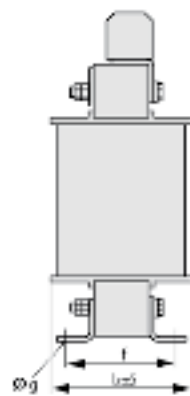

Fig. 3



- ¹⁾ Connection lugs
- ²⁾ Types STI/STZ 0,06 - 0,16 earth connection at bottom

Type	Total Weight kg	Off-load losses W	Short-circuit losses ¹⁾ W	Short-circuit voltage V	Efficiency %	a		b		c		b		c		b		c		e	f	Ø g	b1	c1
						12 V	24 V	42 V	110 V	230 V														

Fig. 1

STZ0,06	1.5	6	5	7.8	0.85	85	75	93	75	93	75	93	75	93	75	93	64	47	4,8 x 8	60	76
STZ0,1	2	7	8	6.9	0.87	85	89	93	89	93	89	93	89	93	89	93	64	61	4,8 x 8	74	76
STZ0,16	2.3	9	12	6.6	0.88	85	97	93	97	93	97	93	97	93	97	93	64	70	4,8 x 8	83	76
STZ0,2	3	11	17	6.6	0.88	106	83	111	83	111	83	111	83	111	83	111	80	63	5,8 x 9	80	94
STZ0,25	3.8	13	14	5.1	0.9	106	108	115	91	111	91	111	91	111	91	111	80	72	5,8 x 9	89	94
STZ0,315	4.3	10	18	5.5	0.92	121	-	-	88	121	88	121	88	121	88	121	90	68	5,8 x 12	86	106
STZ0,4	5.2	17	18	4.4	0.92	121	-	-	88	121	100	121	100	121	100	121	90	80	5,8 x 12	98	106
STZ0,5	6.8	15	24	3.9	0.93	121	-	-	136	125	120	121	120	121	120	121	90	100	5,8 x 12	118	106
STZ0,63	7.7	15	27	4.1	0.94	151	-	-	118	149	107	145	107	145	107	145	122	82	7 x 15	104	132
STZ0,8	9.6	17	25	3.2	0.95	151	-	-	135	149	124	145	124	145	124	145	122	99	7 x 15	121	132
STZ1,0	13.4	27	29	2.9	0.95	151	-	-	161	149	161	149	150	145	150	145	122	125	7 x 15	147	132
STZ1,3	14.9	32	35	3	0.95	175	-	-	145	164	145	164	138	160	138	160	135	110	7 x 15	135	152
STZ1,6	17.4	21	37	2.4	0.96	195	-	-	142	242	146	187	142	183	142	183	150	110	10 x 18	140	170
STZ2,0	21.5	27	33	2	0.97	195	-	-	154	242	158	187	154	183	154	183	150	122	10 x 18	152	170
STZ2,5	21.5	39	43	2.4	0.97	195	-	-	154	242	154	242	158	187	154	183	150	122	10 x 18	152	170

Fig. 2

STZ3,0	26	30	55	2.1	0.97	230	-	-	201	253	231	264	179	274	175	257	190	200	11	-	-
STZ4,0	32	38	88	2.2	0.97	230	-	-	228	253	257	264	205	274	201	257	190	200	11	-	-

Fig. 3

STZ5,3	40	40	165	4	0.96	260	200	*)	200	*)	200	*)	214	374	214	360	230	126	10 x 18	-	-
STZ8,3	55	65	200	4	0.97	260	-	-	230	*)	230	*)	244	374	244	374	230	156	10 x 18	-	-
STZ13,3	80	95	265	3.5	0.97	320	-	-	240	*)	240	*)	270	440	270	440	270	172	13 x 20	-	-

¹⁾The higher rated operating voltage applies, Measurements in mm

¹⁾ Values during average room temperature

Dimension

Three-phase control-isolation/safety transformers DTZ

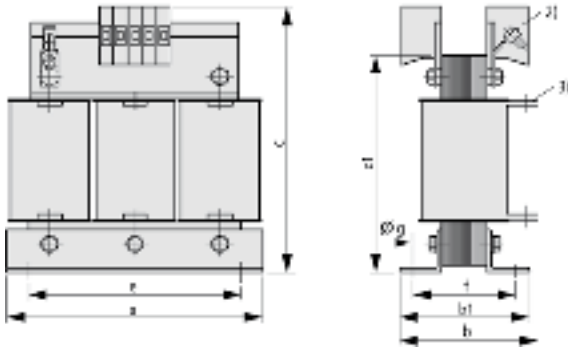

¹⁾ The higher rated operating voltage applies

²⁾ Terminals < 25 A

³⁾ Connection lugs > 63 A

Type	Total Weight kg	Off-load losses W	Short-circuit losses W	Short-circuit voltage %	Efficiency	18.5 V		24 V		42 V		110 V		230 V		e	f	Ø g	b1	c1	
						a	b	c	b	c	b	c	b	c	b						c
DTZ0,1	1.9	5	28	15	0.75	125	62	137	62	137	62	137	62	137	62	137	100	45	5 x 8	61	102
DTZ0,16	2.5	8	20	9.5	0.85	125	72	137	72	137	72	137	72	137	72	137	100	55	5 x 8	71	102
DTZ0,25	3.6	11	25	8.5	0.88	155	77	160	77	160	77	160	77	160	77	160	130	57	8 x 12	77	128
DTZ0,4	5.1	15	40	8	0.88	155	92	160	92	160	92	160	92	160	92	160	130	72	8 x 12	92	128
DTZ0,5	6.1	20	35	6	0.9	190	82	182	112	180	82	182	82	182	82	182	170	58	8 x 12	82	155
DTZ0,63	8.9	25	50	5.5	0.9	190	102	182	132	182	102	182	102	182	102	182	170	78	8 x 12	102	155
DTZ1,0	12.9	35	50	4	0.92	210	125	203	125	203	117	199	117	199	117	199	175	97	8 x 12	117	174
DTZ1,6	18.5	55	60	3	0.93	230	127	222	127	222	127	222	114	218	114	218	176	95	7 x 13	114	198
DTZ2,0	22.4	60	75	3.5	0.94	240	146	278	127	231	127	231	117	227	117	227	185	95	10 x 18	117	208
DTZ2,5	29.3	80	85	2.5	0.94	265	161	298	161	298	140	249	132	245	132	245	200	102	10 x 18	132	228
DTZ4,0	39.6	60	100	2	0.96	300	205	274	174	332	150	278	150	278	147	274	224	119	10 x 18	147	260
DTZ6,3	50.2	66	170	2	0.96	300	231	274	231	274	200	332	176	278	173	274	224	145	10 x 18	173	260
DTZ8,0	55	60	250	4	0.96	390	200	1)	200	1)	200	1)	184	374	184	374	350	126	10 x 18	152	310
DTZ10,0	70	80	280	3.5	0.97	390	-	-	216	1)	216	1)	199	374	199	374	350	141	10 x 18	167	310
DTZ12,5	80	95	300	4	0.97	390	-	-	231	1)	231	1)	214	374	214	374	350	156	10 x 18	182	310
DTZ16	95	100	420	4.5	0.97	450	-	-	221	1)	221	1)	204	434	204	434	400	142	13 x 20	172	360
DTZ20	125	140	400	3.5	0.98	450	-	-	251	1)	251	1)	234	1)	234	434	400	172	13 x 20	202	360
DTZ25	160	180	350	3	0.98	450	-	-	281	1)	281	1)	264	1)	264	434	400	202	13 x 20	232	360

Measurements in mm

Single-phase control, isolation and safety transformers STI - The muscle for your mains supplies

	Rated power kVA	Short-time rating kVA	Preferred voltage 400/230V		Preferred voltage 400/24V		Preferred voltage 230/230V		Preferred voltage 230/24V	
			Type	Article no.	Type	Article no.	Type	Article no.	Type	Article no.
	0.06	0.13	STI0,06(400/230)	029975	STI0,06(400/24)	029971	STI0,06(230/230)	029968	STI0,06(230/24)	029977
	0.1	0.24	STI0,1(400/230)	046630	STI0,1(400/24)	046631	STI0,1(230/230)	029976	STI0,1(230/24)	046629
	0.16	0.36	STI0,16(400/230)	046633	STI0,16(400/24)	046634	STI0,16(230/230)	035247	STI0,16(230/24)	046632
	0.2	0.44	STI0,2(400/230)	046636	STI0,2(400/24)	046637	STI0,2(230/230)	035248	STI0,2(230/24)	046635
	0.25	0.6	STI0,25(400/230)	046638	STI0,25(400/24)	035249	STI0,25(230/230)	036400	STI0,25(230/24)	035262
	0.315	0.75	STI0,315(400/230)	046639	STI0,315(400/24)	035250	STI0,315(230/230)	040641	STI0,315(230/24)	036292
	0.4	1.1	STI0,4(400/230)	046640	STI0,4(400/24)	035251	STI0,4(230/230)	040642	STI0,4(230/24)	036393
	0.5	1.6	STI0,5(400/230)	046641	STI0,5(400/24)	035252	STI0,5(230/230)	040643	STI0,5(230/24)	036394
	0.63	1.7	STI0,63(400/230)	046883	STI0,63(400/24)	035253	STI0,63(230/230)	040644	STI0,63(230/24)	036395
	0.8	2	STI0,8(400/230)	046889	STI0,8(400/24)	035254	STI0,8(230/230)	046641	STI0,8(230/24)	036396
	1	2.8	STI1,0(400/230)	046895	STI1,0(400/24)	035255	STI1,0(230/230)	026642	STI1,0(230/24)	036397
	1.3	3.7	STI1,3(400/230)	046918			STI1,3(230/230)	025256		
	1.6	5.5	STI1,6(400/230)	046952			STI1,6(230/230)	035257		
	2	7	STI2,0(400/230)	035258			STI2,0(230/230)	036398		
	2.5	9	STI2,5(400/230)	035259			STI2,5(230/230)	036399		
	3	11.5	STI3,0(400/230)	035260						
4	15	STI4,0(400/230)	035261							

IEC/EN 61558-2-2/2-4/2-6
VDE 0570 Part 2-2,
Part 2-6 (Safety transformers),
Part 2-4 (isolating transformer)
Rated input voltage
230 ± 5 % V, 400 ± 5 % V
Rated output voltage 24,
230 V

Dimension

Single-phase control-isolation-/safety transformers STI

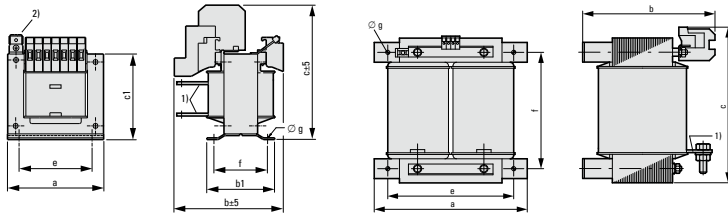

Fig. 1

Fig. 2

- 1) Connection lugs
- 2) Types STI/STZ 0,06 - 0,16 earth connection at bottom

Type	Total Weight kg	Off-load losses W	Short-circuit losses ¹⁾ W	Short-circuit voltage %	Efficiency	a		b		c		b		c		e	f	ø g	b1	c1	
						12 V	24 V	42 V	110 V	230 V											
Fig. 1																					
STI0,06	1.5	6	5	7.8	0.85	85	75	93	75	93	75	93	75	93	75	93	64	47	4.8 x 8	60	76
STI0,1	2	7	8	6.9	0.87	85	89	93	89	93	89	93	89	93	89	93	64	61	4.8 x 8	74	76
STI0,16	2.3	9	12	6.6	0.88	85	97	93	97	93	97	93	97	93	97	93	64	70	4.8 x 8	83	76
STI0,2	3	11	17	6.6	0.88	106	83	111	83	111	83	111	83	111	83	111	80	63	5.8 x 9	80	94
STI0,25	3.8	13	14	5.1	0.9	106	108	115	91	111	91	111	91	111	91	111	80	72	5.8 x 9	89	94
STI0,315	4.3	10	18	5.5	0.92	121	-	-	88	121	88	121	88	121	88	121	90	68	5.8 x 12	86	106
STI0,4	5.2	17	18	4.4	0.92	121	-	-	88	121	100	121	100	121	100	121	90	80	5.8 x 12	98	106
STI0,5	6.8	15	24	3.9	0.93	121	-	-	136	125	120	121	120	121	120	121	90	100	5.8 x 12	118	106
STI0,63	7.7	15	27	4.1	0.94	151	-	-	118	149	107	145	107	145	107	145	122	82	7 x 15	104	132
STI0,8	9.6	17	25	3.2	0.95	151	-	-	135	149	124	145	124	145	124	145	122	99	7 x 15	121	132
STI1,0	13.4	27	29	2.9	0.95	151	-	-	161	149	161	149	150	145	150	145	122	125	7 x 15	147	132
STI1,3	14.9	32	35	3	0.95	175	-	-	145	164	145	164	138	160	138	160	135	110	7 x 15	135	152
STI1,6	17.4	21	37	2.4	0.96	195	-	-	142	242	146	187	142	183	142	183	150	110	10 x 18	140	170
STI2,0	21.5	27	33	2	0.97	195	-	-	154	242	158	187	154	183	154	183	150	122	10 x 18	152	170
STI2,5	21.5	39	43	2.4	0.97	195	-	-	154	242	154	242	158	187	154	183	150	122	10 x 18	152	170
Fig. 2																					
STI3,0	26	30	55	2.1	0.97	230	-	-	201	253	231	264	179	274	175	257	190	200	11	-	-
STI4,0	35	38	88	2.2	0.97	230	-	-	228	253	257	264	205	274	201	257	190	200	11	-	-

¹⁾ Values during average room temperature, Measurements in mm

Single-phase multi-winding transformer UTI - The master of flexibility

Single-phase multi-winding transformer	Rated power kVA	Rated input voltage V	Rated output voltage V	Type	Article no.
	0.2	380 400 415	UTI,02-115	206924	
	0.315	440 460	UTI0,315-115	206925	
	0.5	480 500	UTI0,5-115	206926	
	0.63	525 550	UTI0,63-115	206927	
	0.8	575 600	UTI0,8-115	206928	
	1		UTI1,0-115	206929	

(Universal) control, isolation and safety transformers according to VDE 0550, IEC/EN 61558-2-2/2-4/2-6 VDE 0570 Part 2-2, Part 2-6 (Safety transformer), Part 2-4 (Isolation transformer)

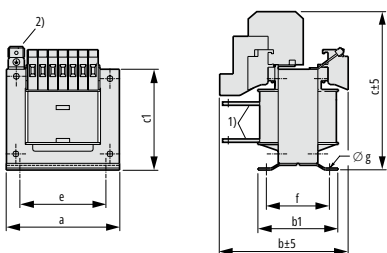

¹⁾ Maximum space requirement

²⁾ With Type UTI1,1 earth connection at bottom

Type	Total weight kg	Off-load losses W	Load losses W	Short-circuit voltage %	Efficiency	U = 24 V			U = 115 V			e	f	ø g	
						a	b1	c1	b	c	b				c
UTI0,1	2	8	11	7.5	0.84	85	74	76	89	93	89	93	64	61	4.8 x 8
UTI0,2	3	10	19	6.5	0.87	106	80	94	83	111	82	112	80	63	5.8 x 12
UTI0,315	4.3	15	23	5	0.89	121	86	106	88	124	88	121	90	68	5.8 x 12
UTI0,5	6.8	26	23	3.5	0.92	121	118	106	140	133	120	121	90	100	5.8 x 12
UTI0,63	7.7	25	32	3.8	0.92	151	104	132	122	159	107	145	122	82	7 x 15
UTI0,8	9.6	33	29	2.8	0.93	151	121	132	139	159	124	145	122	99	7 x 15
UTI1,0	13.4	46	30	2.1	0.93	151	147	132	165	159	150	145	122	125	7 x 15

Measurements in mm

Common configurations for three-phase transformers

Through different configurations of the the primary and secondary winding (star, delta or inter-star) many possible combinations become available, which can be selected by

purpose. These are collected as configurations according to EN60076-1.

Additional switching groups on request

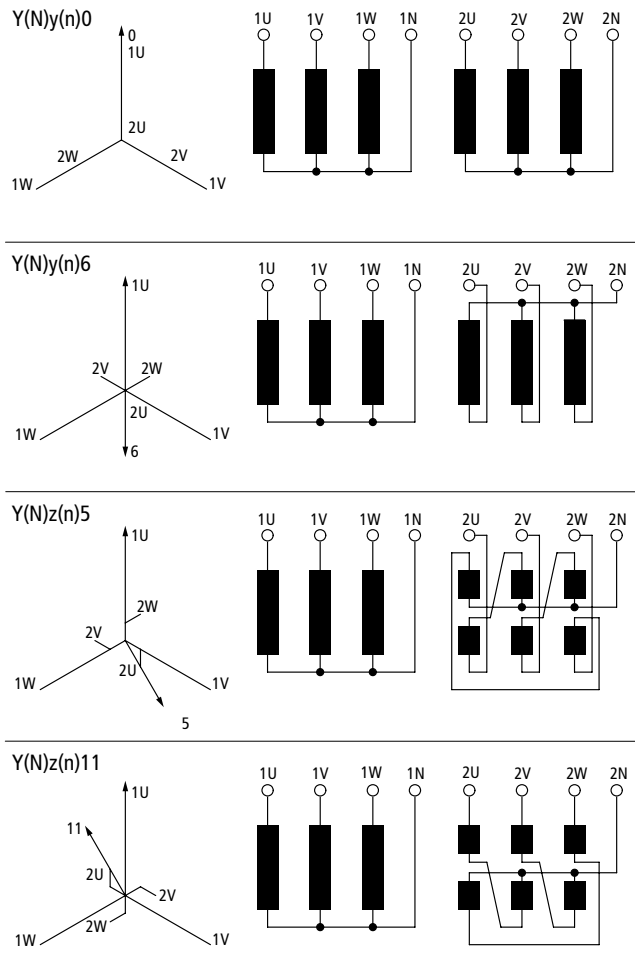
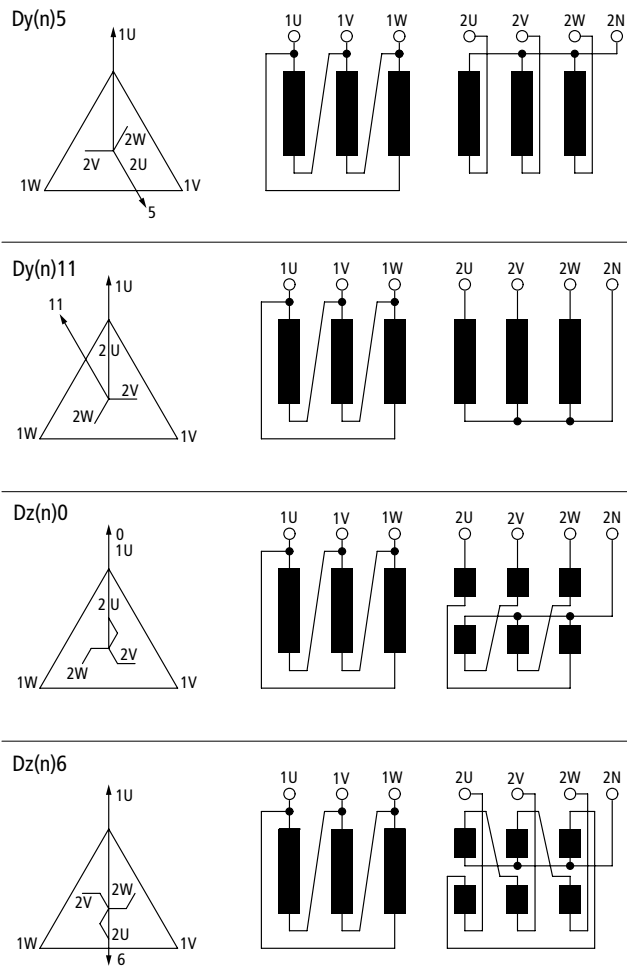

The accessible star point is made clear by an added n secondary (N primary) to the switching group. Standard circuit is Yy0.

	①	③		②	③
U1-1.1	208	1.1-1.9/1.2-1.3	U2-2.1	115	2.1-2.4/2.3-2.2
	230	1.1-1.8/1.2-1.4	2.3	230	2.3-2.4
	380	1.3-1.0	2.4		
1.3	400	1.4-1.0	0-2.2		
1.4	415	1.3-1.9			
1.5	440	1.4-1.9			
1.6	460	1.4-1.8			
1.7	480	1.5-1.8			
1.8	500	1.6-1.8			
1.9	525	1.3-1.7			
1.0	550	1.4-1.7			
	575	1.5-1.7			
0-1.2	600	1.6-1.7			

- ① primary voltage [V]
- ② secondary voltage [V]
- ③ bridge

Example:

If the transformer will be connected to a 460 V rated input voltage, bridge the terminals 1.4 and 1.8. If the transformer will have a 230 V rated output voltage, bridge the terminals 2.3 and 2.4.

Determination of the continuous rating

The control transformer must be rated in size so that the voltage drop remains within the permissible tolerance range even under unfavourable conditions.

The determination of the transformer rating is performed by the addition of all the sealing powers of all loads which are to be connected simultaneously as well as addition of the inrush power of the largest load, and multiplying the result by a factor of 0.8. If the ratings of the loads are very similar, the sum of all inrush powers of the simultaneously connected loads is added to the sum of all the sealing powers and the result is multiplied by a factor of 0.8.

Determination of the short-time rating

If the primary requirement is to switch large contactors, it is recommended that the control transformer is selected on the basis of the short-time rating. In most cases, this will mean that the transformer rating is reduced.

It is important to ensure that the sealing power does not exceed the continuous rating.

Eaton Online Catalog – find product details quickly and efficiently!

You can find comprehensive up-to-date product information at <https://ecat.eaton.com>

Search

Keywords, common type references or part numbers, technical benchmark data: Search can validate any input and leads you to your desired product.

Graphical navigation

Graphical representation of the fields of application and product groups.

Selection aids

Aligned to a typical experts approach: Search aids lead you to your desired product quickly.

Data Sheets

For each product in the catalog: Generate a data sheet with all detailed technical information. Just one click converts it to pdf and then it is ready for printing or saving.

Parts lists

From your search results you can create a parts list which you can then send to your Eaton sales partner as a query.



HTML data sheet. Can be saved as pdf or excel.



Parts list, e.g. for queries to Eaton Sales.

You can find comprehensive up-to-date information about Eaton's automation products and switchgear in our Online Catalog or on **Eaton.com**.



Eaton is an intelligent power management company dedicated to improving the quality of life and protecting the environment for people everywhere. We are guided by our commitment to do business right, to operate sustainably and to help our customers manage power today and well into the future. By capitalizing on the global growth trends of electrification and digitalization, we're accelerating the planet's transition to renewable energy, helping to solve the world's most urgent power management challenges, and doing what's best for our stakeholders and all of society. For more information, visit www.eaton.com.

Eaton addresses worldwide: **Eaton.com/contacts**



Eaton
EMEA Headquarters
Route de la Longeraie 7
1110 Morges
Switzerland
[Eaton.com](https://www.eaton.com)

Electrical Sector
Eaton Industries GmbH
Hein-Moeller-Str. 7-11
53115 Bonn
Germany

© 2018 Eaton
All Rights Reserved
Publication No. BR009002EN
May 2025

The products, information and prices contained in this document are subject to change. The same is true for any errors or omissions. Only the order confirmation and the technical documentation received from Eaton are binding. Photos and illustrations are indicative only and do not serve as proof of any appearance or functionality. Their use in any form must be approved in advance by Eaton. The same applies for brand names (in particular Eaton, Moeller, Cutler-Hammer, Cooper and Bussmann). Eaton's terms of sale, as published on Eaton's websites and included with order confirmations received from Eaton, apply.

Eaton is a registered trademark.

All other trademarks are property of their respective owners.

Follow us on social media to get the latest product and support information.

