

## Data Sheet | Item Number: 771-9293/017-801

pre-assembled interconnecting cable; B2ca; Socket/plug; 3-pole; Cod. A; H05Z1Z1-F 3G 2.5 mm<sup>2</sup>; 8 m; 2,50 mm<sup>2</sup>; black

<https://www.wago.com/771-9293/017-801>



Color: ■ black

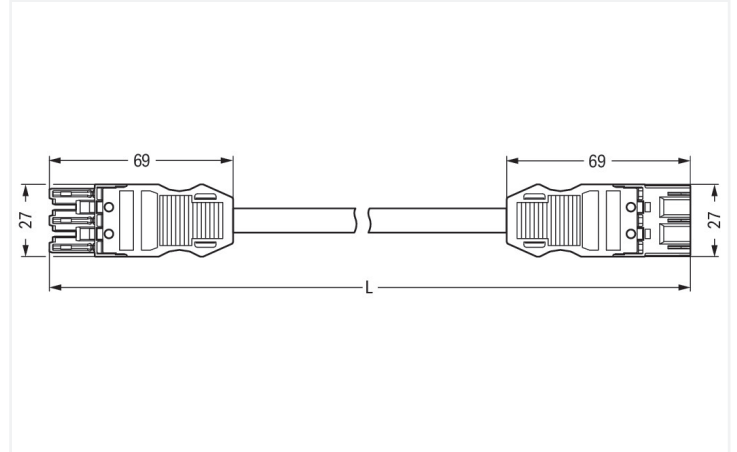

Dimensions in mm

### Cable assembly WINSTA® MIDI A coding

The WINSTA® MIDI cable assembly with protection against mismatching supports fast, reliable installation. WAGO pluggable installation connectors can be used when criteria repeat or are planned on a specified grid, for example for installing grid lighting or flush-mount lighting. The mechanical coding and color coding of the pluggable installation connector ensure error-free installation of the individual components – including protection against mismatching. The pluggable installation connector offers touch-proof protection with live components in accordance with protection type IP20 (When mated: IP2xC (These compact connectors are not designed for use in open, easily accessible areas!)). General mains applications for almost any domain of use can be realised with WINSTA® MIDI pluggable installation connectors with A coding. This pluggable installation connector is used for electrical currents up to 20 A. Thus the product is especially suitable for high power loads. Our WINSTA® MIDI product line offers maximum flexibility for the electrical installation. With its Push-in CAGE CLAMP® spring pressure connection technology, it ensures error-free, time-saving installation and offers flexibility and customization for meeting an enormous variety of installation requirements. Anyone who needs to worry about technical safety requirements related to fire protection for electrical installation should use only top quality components. Our product meets the strict safety standards of fire class B2. The cable assembly is halogen-free. This eliminates the addition of environmental pollutants during production. It also achieves a higher fire class, since halogen-free materials are flame-resistant.

### Fast, error-free assembly thanks to cable assemblies from WAGO

The cable is pre-assembled with a socket and a plug. The WINSTA® Pluggable Connection System is ideally tailored to the very strict requirements of building installation. It makes electrical installation pluggable, and thus faster, even more reliable, and error-free. Using this pre-assembled system decreases assembly times and errors during installation at the construction site. Now you can also cut installation expenses without compromising safety and quality: with fire class B2 eliminates the need for servicing and prevents unnecessary downtime.

- protection against mismatching eliminates errors
- pre-assembled versions
- with A coding for use in many general mains applications
- custom-engineered solutions
- quick replacement of defective units during ongoing operation

## Notes

Note Cables with a different fire class can be found in the eShop.

## Electrical data

Ratings per	IEC/EN 60664-1			General information	
Overtoltage category	III	III	II	Note on contact resistance	approx. 1 mΩ of contact resistance approx. 0.25 mΩ contact transition plug/ socket
Pollution degree	3	2	2		
Nominal voltage	250 V	-	-		
Rated impulse withstand voltage	4 kV	-	-		
Rated current	20 A	-	-		

## Connection Data

Total number of potentials	3	<b>Connection 1</b>	
PE function	Preceding PE contact	Pole number	3
		Wire cross-section	2.5 mm <sup>2</sup>
		Connection type	Socket - Plug

## Physical data

Pin spacing	10 mm / 0.394 inches
Width	27 mm / 1.063 inches
Height	12.9 mm / 0.508 inches
Total length	8 m

## Mechanical data

Use	General mains applications
Coding	A
Variable coding	Yes
Marking	L ⊕ N
Potential marking	L ⊕ N
Mating force of a plug-in connection	approx. 20 ... 70 N (depending on pole number)
Retention force of a plug-in connection	when locked: > 80N
Unmating force of a plug-in connection	when unlocked: approx. 20 ... 70 N (depending on pole number)
Number of mating cycles	200, without resistive load
Connection type	Socket - Plug
Type of pre-assembled cable	Interconnecting cable
Cable type	H05Z1Z1-F 3G2.5
Protection type	IP20; When mated: IP2xC (These compact connectors are not designed for use in open, easily accessible areas!)

## Plug-in connection

Mismating protection	Yes
Note on mismating protection	All <i>WINSTA</i> ® components are 100% protected against mismating when: a.) plugging different numbers of poles b.) plugging while rotated 180 c.) plugging while laterally staggered d.) plugging one pole
Locking lever	Can be retrofitted
Locking of plug-in connection	Locking lever
Note on locking system	All connectors for mounted installations (snap-in versions for lighting fixtures or devices, all types of PCB and distribution connectors) are factory-equipped with locking levers to ensure plugs and sockets are securely locked. Additional locking levers are only required for flying leads (plug/socket).

### Material data

Note (material data)	<a href="#">Information on material specifications can be found here</a>
Color	black
Insulation material (main housing)	Polyamide (PA66)
Flammability class per UL94	V0
Fire class per EN 50575	B2 <sub>ca</sub>
Contact material	Copper or copper alloy; surface-treated
Contact Plating	Tin
Fire load	0.601 MJ
Connector color	black
Strain relief color	black
Printing color of strain relief	white
Sheathed cable color	black
Printing color of sheathed cable	white
Halogen-free	Yes
Silicon-free	Yes
Sheath material	Halogen-free
Rubber cable	No
Weight	1278.3 g
Copper weight of the raw cable	0.072 kg/m

### Environmental requirements

Processing temperature	-5 ... +40 °C
Continuous operating temperature	-35 ... +85 °C
Note on continuous operating temperature	Cable for temperatures ≤ 70 °C (including halogen-free) Insulating parts for temperatures ≤ 105 °C

### Commercial data

PU (SPU)	1 pcs
Packaging type	unpacked
Country of origin	PL
GTIN	4055143669245
Customs tariff number	85444290900

### Product Classification

UNSPSC	26121629
eCl@ss 10.0	27-44-06-04
eCl@ss 9.0	27-44-06-04
ETIM 9.0	EC002587
ETIM 10.0	EC002587
ECCN	NO US CLASSIFICATION

### Environmental Product Compliance

RoHS Compliance Status	Compliant, No Exemption
------------------------	-------------------------

## Downloads

### Environmental Product Compliance

#### Compliance Search

Environmental Product Compliance  
771-9293/017-801



## Documentation

### Bid Text

771-9293/017-801	19.02.2019	xml 2.95 KB	
771-9293/017-801	01.12.2017	doc 25.00 KB	

## CAD/CAE-Data

### CAE data

EPLAN Data Portal  
771-9293/017-801



## 1 Compatible Products

### 1.1 Required Accessories

#### 1.1.1 Locking system

##### 1.1.1.1 Locking system



**Item No.: 770-101**

Locking lever; for flying leads; for manual operation; black

**Item No.: 770-121**

Locking lever; for flying leads; for manual operation; white

**Item No.: 770-111**

Locking lever; for flying leads; for tool operation; black

**Item No.: 770-131**

Locking lever; for flying leads; for tool operation; white

### 1.2 Optional Accessories

#### 1.2.1 Cover

##### 1.2.1.1 Cover



**Item No.: 770-201**

Lockout cap; 12-pole, separable; for sockets; Plastic; black

**Item No.: 770-221**

Lockout cap; 12-pole, separable; for sockets; Plastic; white

**Item No.: 770-360**

Lockout cap; for plugs; 5-pole; separable; yellow

**Item No.: 897-2003**

Protective cap; Type2; for sockets and plugs; PVC; red

## 1.2.2 Installation

### 1.2.2.1 Mounting accessories



**Item No.: 770-310**

Mounting carrier; 2- to 5-pole; for flying leads; black

## 1.2.3 Marking

### 1.2.3.1 Marker



**Item No.: 770-450/000-006**

Marker card; Plastic; blue



**Item No.: 770-450/000-001**

Marker card; Plastic; green



**Item No.: 770-450/000-012**

Marker card; Plastic; orange



**Item No.: 770-450/000-005**

Marker card; Plastic; red



**Item No.: 770-450**

Marker card; Plastic; white



**Item No.: 770-450/000-002**

Marker card; Plastic; yellow

### 1.2.3.2 Marking strip



**Item No.: 210-334**

Marking strips; as a DIN A4 sheet; Strip width 5 mm; Strip length 182 mm; plain; Self-adhesive; white