

## Data Sheet | Item Number: 216-546

Twin ferrule only for 811 series; Sleeve for 2 x 4 mm / AWG 12; insulated; Nominal current 63 A; gray

<https://www.wago.com/216-546>

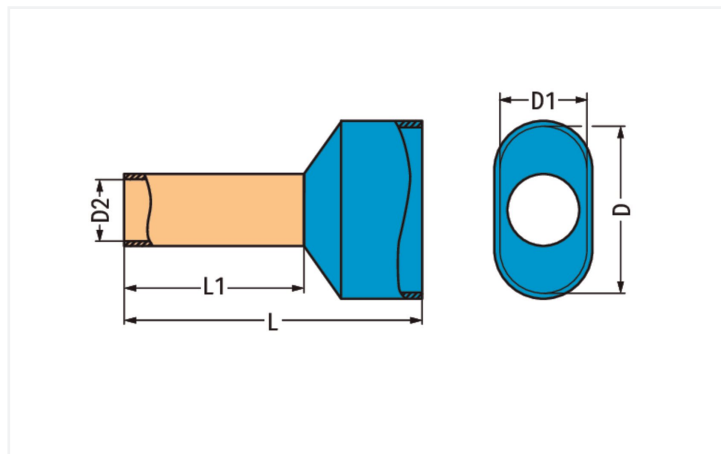

Color: ■ gray

Similar to illustration

### Connection data

Strip length	12 mm / 0.47 inches
Fine-stranded conductor	4 mm <sup>2</sup> / 12 AWG

### Physical data

Length	22 mm
Crimp length (length of sleeve)	12 mm
Diameter	9 mm
Inner Diameter plastic collar	5.2 mm
Diameter crimp sleeve inside	3.5 mm

### Material data

Color	gray
Fire load	0 MJ
Weight	1.1 g

### Commercial data

eCl@ss 10.0	27-40-02-01
eCl@ss 9.0	27-40-02-01
ETIM 8.0	EC000005
ETIM 7.0	EC000005
PU (SPU)	100 (100) pcs
Packaging type	Box
Country of origin	DE
GTIN	4055143583350
Customs tariff number	85369010000

Environmental Product Compliance	
RoHS Compliance Status	Compliant, No Exemption

## Downloads

### Environmental Product Compliance

Compliance Search	
Environmental Product Compliance 216-546	<a href="#">↓</a>

## Documentation

Bid Text			
216-546	19.02.2019	xml 2.62 KB	<a href="#">↓</a>
216-546	28.04.2017	doc 22.50 KB	<a href="#">↓</a>

## Installation Notes

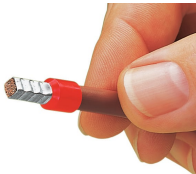

A perfect gas-tight crimp – both electrical-ly and mechanically reliable