

## Data Sheet | Item Number: 216-545

Twin ferrule only for 811 series; Sleeve for 2 x 2.5 mm / AWG 14; insulated; Nominal current 63 A; blue

<https://www.wago.com/216-545>

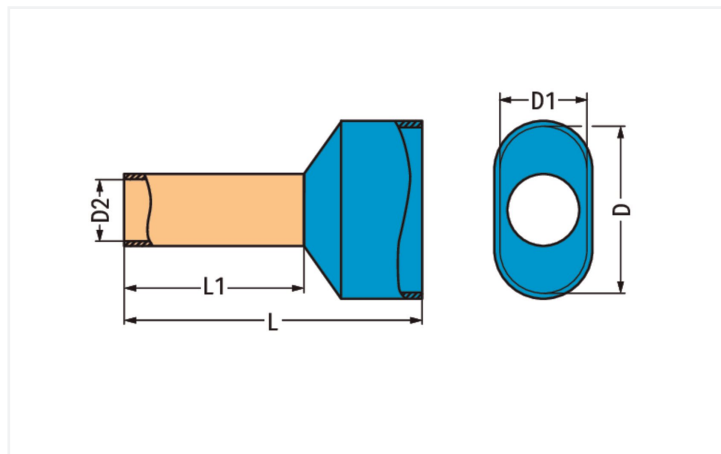

Color: ■ blue

### Connection data

Strip length	12 mm / 0.47 inches
Fine-stranded conductor	2.5 mm <sup>2</sup> / 14 AWG

### Physical data

Length	21 mm
Crimp length (length of sleeve)	12 mm
Diameter	8 mm
Inner Diameter plastic collar	4.5 mm
Diameter crimp sleeve inside	2.8 mm

### Material data

Color	blue
Fire load	0 MJ
Weight	0 g

### Commercial data

Product Group	2 (Terminal Block Accessories)
eCl@ss 10.0	27-40-02-01
eCl@ss 9.0	27-40-02-01
ETIM 8.0	EC000005
ETIM 7.0	EC000005
PU (SPU)	100 pcs
Packaging type	Box
Country of origin	DE
GTIN	4045454432942
Customs tariff number	85369010000

Environmental Product Compliance	
RoHS Compliance Status	Compliant, No Exemption

## Downloads

### Environmental Product Compliance

Compliance Search	
Environmental Product Compliance 216-545	<a href="#">↓</a>

## Documentation

Bid Text			
216-545	19.02.2019	xml 2.62 KB	<a href="#">↓</a>
216-545	28.04.2017	doc 22.50 KB	<a href="#">↓</a>

## Installation Notes

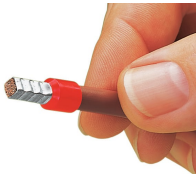

A perfect gas-tight crimp – both electrical-ly and mechanically reliable