INSTRUCTION HANDBOOK
2TFH400010A1001

InLineII ZLBM00-100

DECOMMISSIONING INSTRUCTIONS



Table of Contents

InLineII ZLBM00-100

1. Scope	4
2. Safety and protection	4
2.1 Precautions	4
2.2 Personal protective equipment (PPE)	4
3. Use of symbols	5
4. Description of each step	5
5. Decommissioning step-by-step	6
5.1 Phase 1 - Fasteners separation	6
5.1.1 Remove cover from base assembly	6
5.1.2 Remove the cable shroud from middle part	6
5.1.3 Remove the middle part from base assembly	7
5.2 Phase 2 - Base assembly separation	8
5.2.1 Remove the busbar terminals	8
5.2.2 Remove technical label	9
5.2.3 Remove the traceability label	9
5.2.4 Summary of all 5.2 Phase	10
5.3 Phase 3a – Basic cover assembly separation	11
5.3.1 Dismount the handle	11
5.3.2 Dismount the transparent cover	11
5.3.3 Remove the front type label	11
5.3.4 Remove fuse holder	12
5.3.5 Summary of all 5.3 parts	12
6. Summary of all parts, available for recycling or disposal	13
7. Energy consumption for InLineII ZLBM00-100 decommissioning	14
8. Recycling information in accordance with the WEEE	14

1. Scope

The following document provides step-by-step instructions on how to decommission your End-of-life In-Linell ZLBM00-100 fuse switch disconnecter.

If you have any doubts about the steps, please contact your local ABB Contact Center for support.

2. Safety and protection



2.1 Precautions

Before proceeding with any of the operations described here, the InLinell Fuse switch disconnecter should be removed from the cabinet where it was working, by qualified electrician, following the safety procedures and protocols, valid for the area in use.

Electrically skilled personnel must perform decommissioning of End-of-life product (recommended IEV 195-04-01 person with relevant education and experience to enable him or her to perceive risks and to avoid hazards which electricity can create), following the rules for ergonomics, safety standards and any additional local law requirements, valid at time of performing the described operation.

ABB declines any responsibility for injury to people or damage to property resulting from a failure to comply with the instructions set out in this document and with any applicable safety standard.

2.2 Personal protective equipment (PPE)

While performing decommissioning, the personnel must wear the following PPE:



3. Use of symbols

Warning

Specific steps of this instruction require extra caution, due to higher risk of hazard. These steps are marked with a hazard triangle in the text.



Part separation information

Shows all of the components and notations of specific materials in each phase.



4. Description of each step

Each phase and step include text, describing the process, tools (in italic), picture and a table containing separated parts.

At the end of the document, there is a summary table listing all parts separated during the process.

5. Decommissioning step-by-step

5.1 Phase 1 – Separate into main parts

5.1.1 Remove cover from the base assembly

Manually move the cover to the open position. Push the two buttons located behind the handle, and then remove the cover from the base assembly.

1

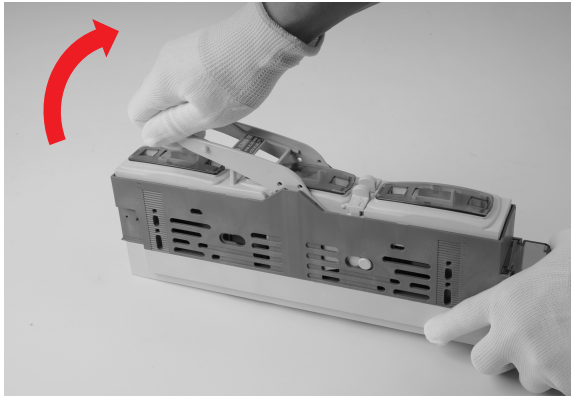

2

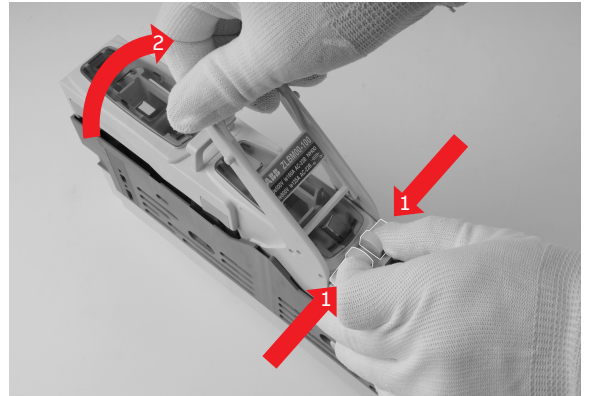

5.1.2 Remove the cable shroud from the middle part

The cable shroud is not attached to the middle part and can be removed by hand.

3

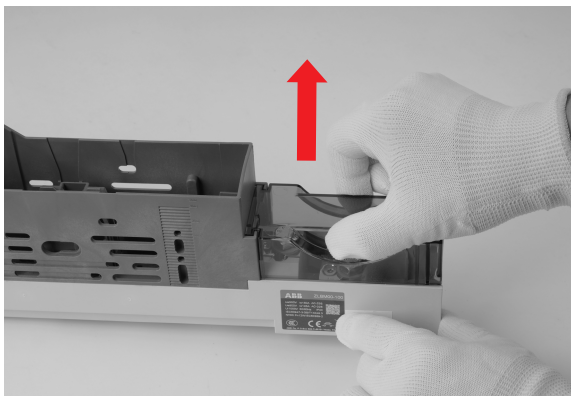

Tools

Flat-head
screwdriver



5.1.3 Remove the middle part from the base assembly

Use a flat-head screwdriver to lift the four pairs of clasps at the bottom and remove the middle part from the base assembly. Then, use a flat-head screwdriver to lift the three small covers at the bottom of the middle part.

4

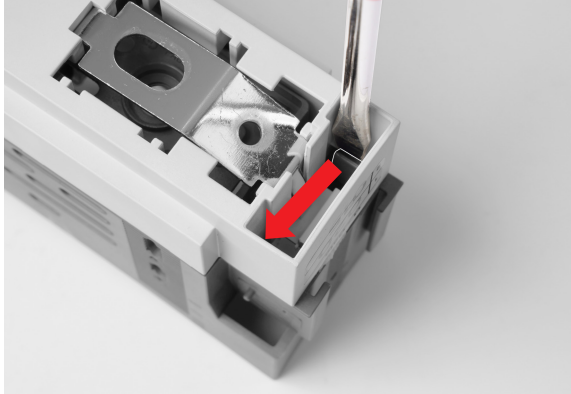

5

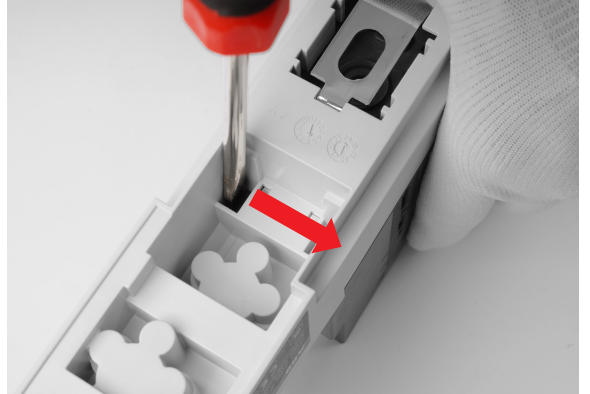

6

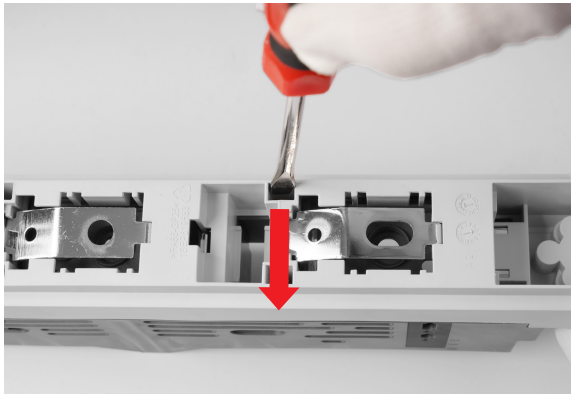

7

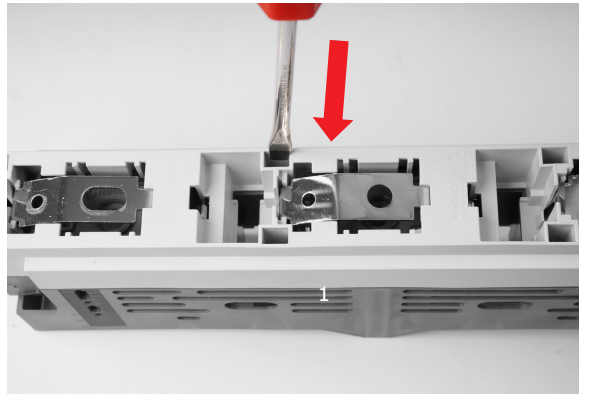

8

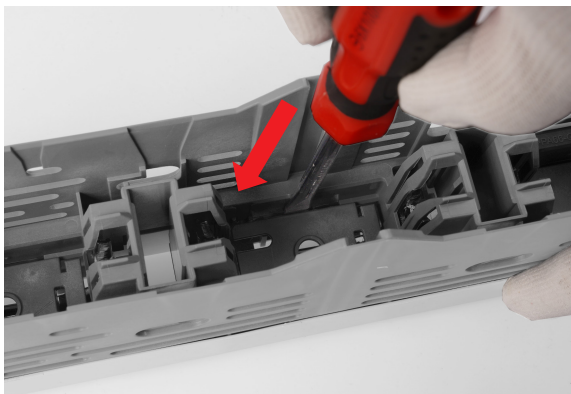

9

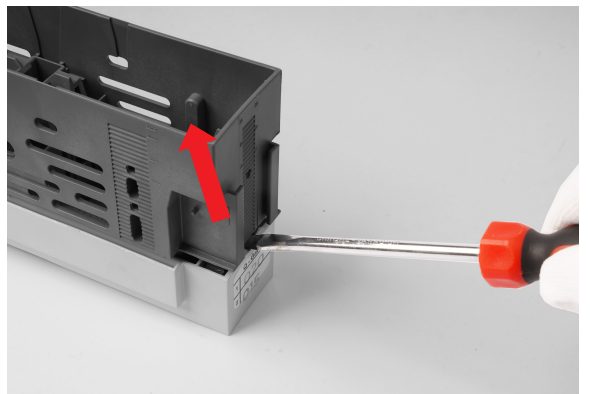

5.2 Phase 2 – Base assembly separation

Flat-head screwdriver



5.2.1 Remove the busbar terminals

5.2.1.1 Remove the busbar terminal L1, L2, L3

Use a flat-head screwdriver to lift the plastic clip at the bottom, and then push the cable entry plate out by hand.

10

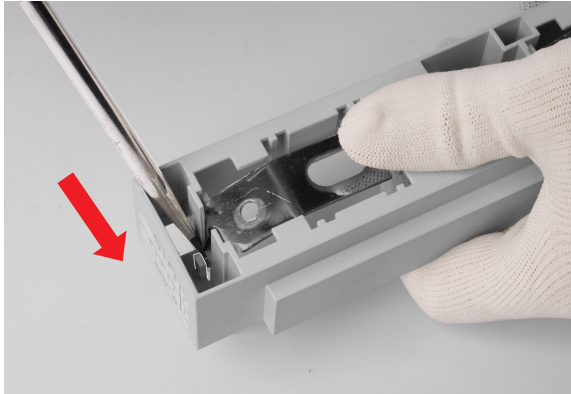

11

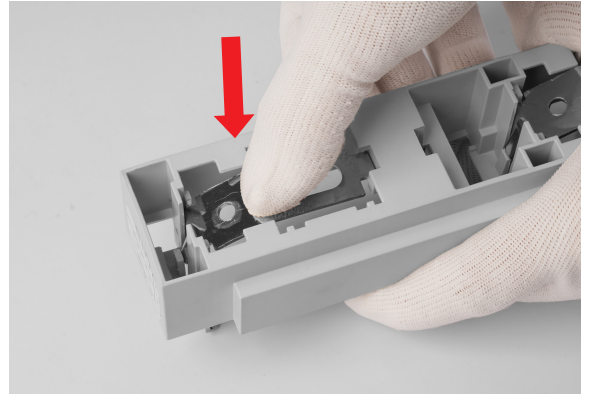

Tools

Hexagonal screwdriver

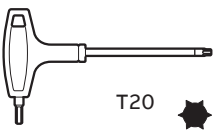

T20

Spanner



5.2.1.2 Remove the cable terminal L1, L2, L3

Remove the fixing screws using a wrench and a hexagonal screwdriver, and then take off the three outlet plates.

12



13

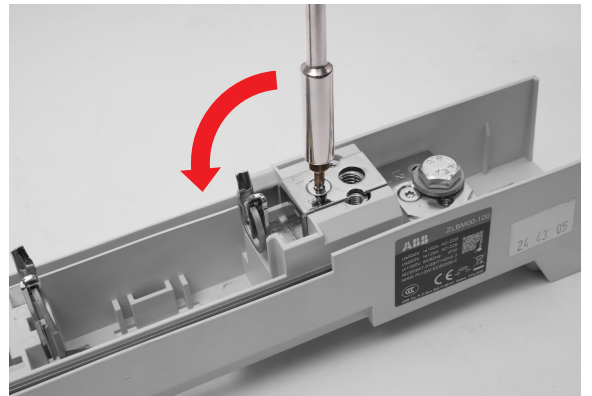

14

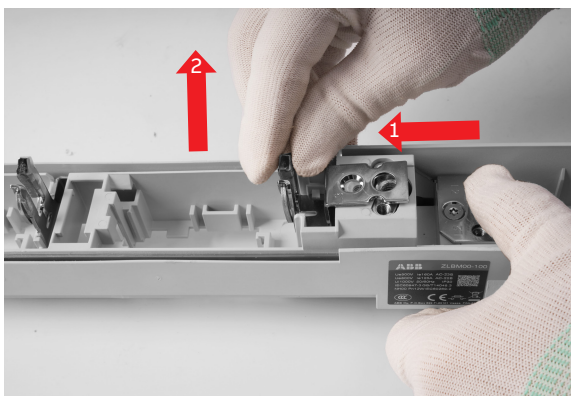

15

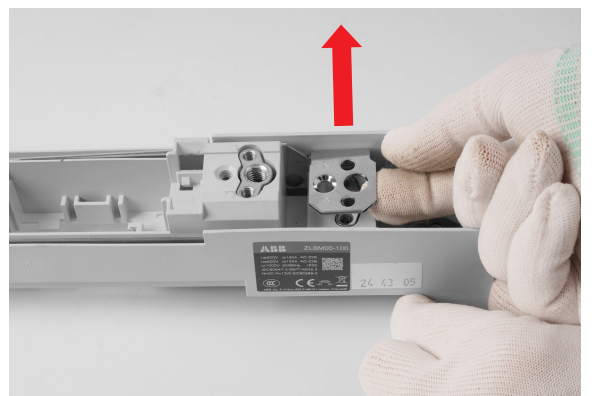

16

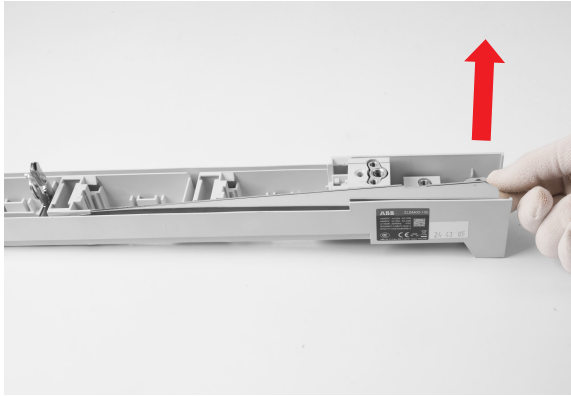

Tools

Cutter

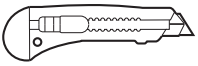

5.2.2 Remove the technical label

Use a cutter to lift a corner of the label, and then remove it by hand.

17

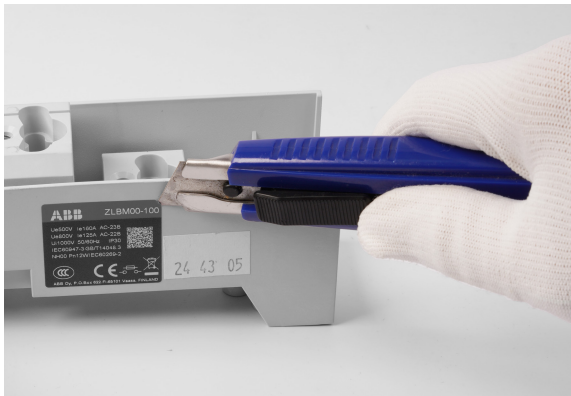

Tools

Cutter

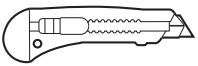

5.2.3 Remove the traceability label

Use a cutter to lift a corner of the label, and then remove it by hand.

18

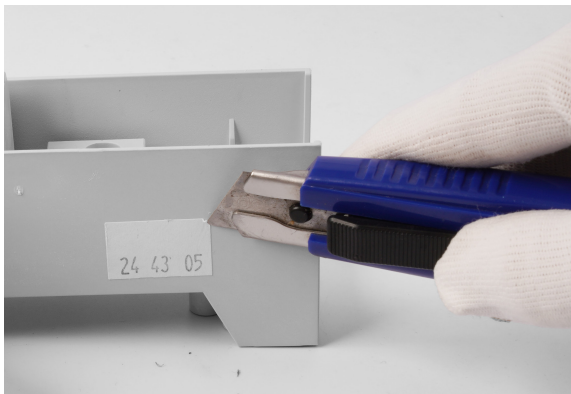

5.2.4 Summary of the Phase 5.2 – Base assembly separation

19

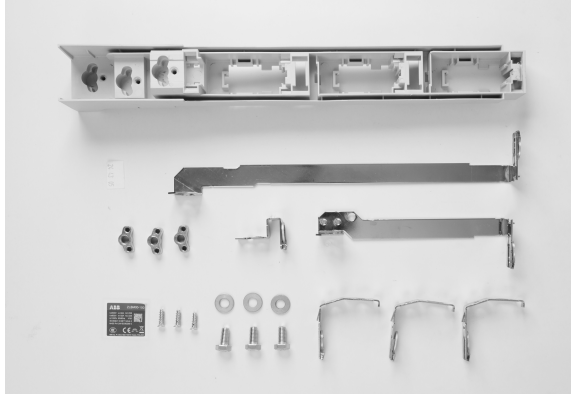

Summary table as below:



Description	Qty (pcs)	Type	Special separation needed
Screws	6	Metal	-
Conical spring washer	3	Metal	-
Cable terminal	3	Metal	-
Busbar terminal	3	Metal	-
Fixing plate 2xM5 + 1xM8	3	Metal	-
Contacts spring	6	Metal	-
Base	1	Plastic	Yes (thermoplastic containing brominated flame retardants)
Technical label	1	Plastic	-
Traceability label	1	Paper	-

5.3 Phase 3 – Basic cover assembly separation

Tools

Flat-head
screwdriver



5.3.1 Dismount the handle

Place the handle in the closed position, and then remove the handle from the buckle on both sides.

20

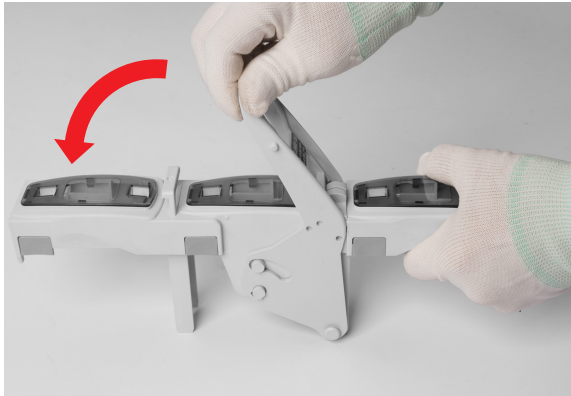

21

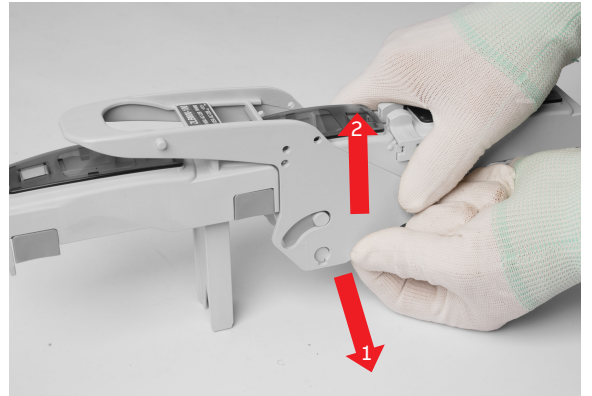

Flat-head
screwdriver

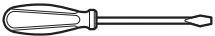

5.3.2 Dismount the transparent cover

Flip the cover and locate the clips. Using a flat-head screwdriver, pry the clips and push the transparent cover to make it fall.

22

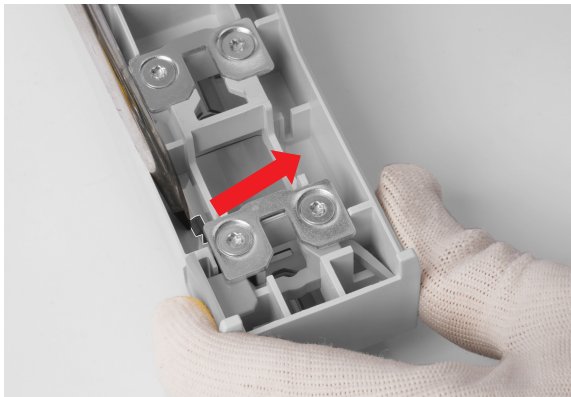

23

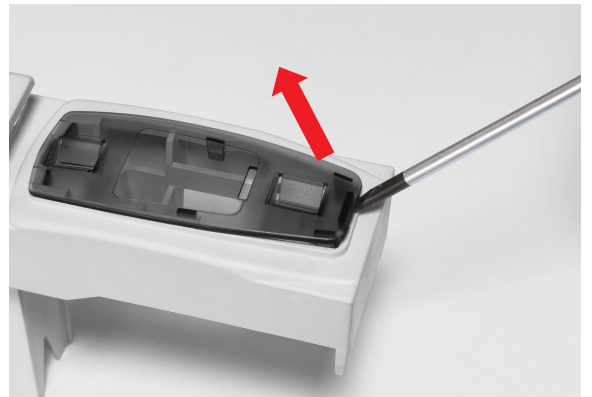

Tools

Cutter

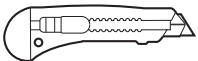

5.3.3 Remove the type label

Use a cutter to lift a corner of the label, and then remove it by hand.

24



Tools

Hexagonal
screwdriver

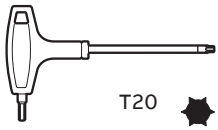

5.3.4 Remove the fuse holder

Remove the screws using a flat-head screwdriver, and then manually remove the plastic springs.

25

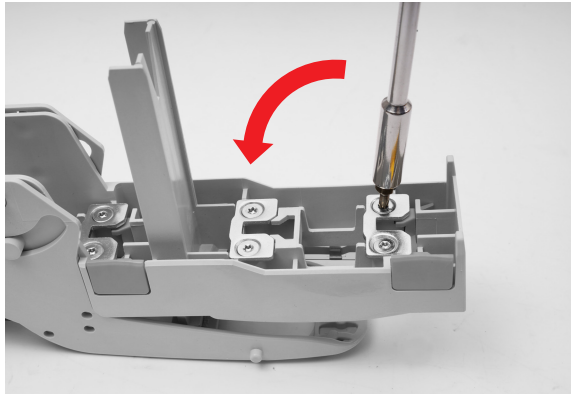

26

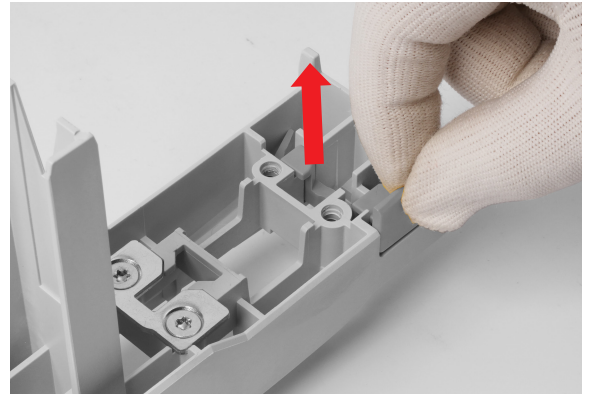

5.3.5 Summary of the Phase 5.3 – Basic cover assembly separation

27

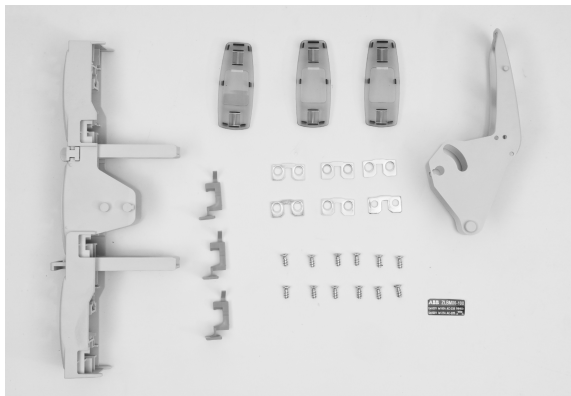

Summary table as below:



Description	Qty (pcs)	Type	Special separation needed
Transparent cover	3	Plastic	-
Front cover	1	Plastic	Yes (thermoplastic containing brominated flame retardants)
Front type label	1	Plastic	-
Front QR label	1	Plastic	-
Handle	1	Plastic	Yes (thermoplastic containing brominated flame retardants)
Fuse holder	6	Metal	-
Fuse release	3	Plastic	Yes (thermoplastic containing brominated flame retardants)
Screws	12	Metal	-

7. Energy consumption for InLinell ZLBM00-100 decommissioning

All listed step-by-step operations are performed manually.
As a result, carbon emissions can be considered negligible.

8. Recycling information in accordance with the WEEE

Recycling in accordance with EN 50419:2022 (separate collection of waste of electrical and electronic equipment)

Our products are marked in compliance with Directive 2012/19/EU (crossed-out wheeled bin symbol):

Important Notice: Do not dispose of the entire end-of-life product as regular waste. Follow the decommissioning steps outlined in this instructions manual. Ensure all components are separated for appropriate disposal, as indicated in the summary table above, and in accordance with all applicable local laws and regulations.

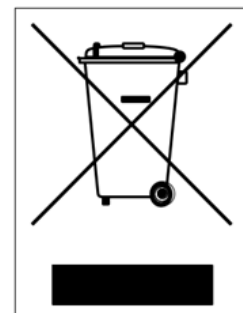



Contact us

ABB Oy
Protection and Connection
P.O. Box 622
FI-65101 Vaasa
Finland

abb.com/lowvoltage