

## MATERIALEN

| Nummer | Omschrijving     | Materiaal                |
|--------|------------------|--------------------------|
| 1      | Gevlochten slang | TPSiV- AISI 304          |
| 2      | Pershuls         | AISI 304                 |
| 3      | Tule             | CW 617 N-DW UNI EN 12164 |
| 4      | Dichting         | EPDM                     |
| 5      | Wartel           | CW 617 N UNI EN 12165    |
| 6      | Fitting          | CW617N-DW UNI EN 12164   |
| 7      | Klemmoer         | CW 614 N UNI EN 12164    |
| 8      | Klemring         | CW 614N-DW UNI EN 12164  |



## TECHNISCHE GEGEVENS

| Algemeen                     |           |
|------------------------------|-----------|
| Maximale druk                | 10 bar    |
| Maximale bedrijfstemperatuur | 70°C      |
| Gewicht                      | 86,1 Gram |
| Lengte (L)                   | 500 mm    |
| Tolerantie (L)               | 20 mm     |

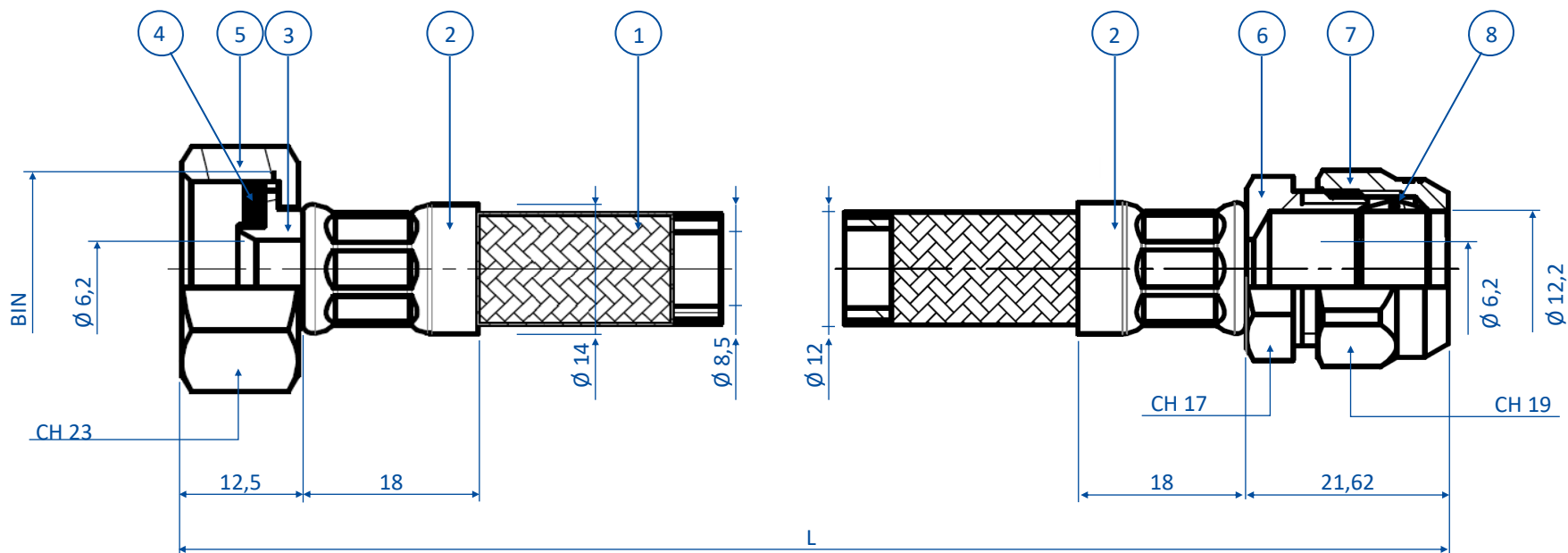

CH = Steeksleutelmaat