

# Data Sheet | Item Number: 216-1543

Twin ferrule; insulated; black

<https://www.wago.com/216-1543>

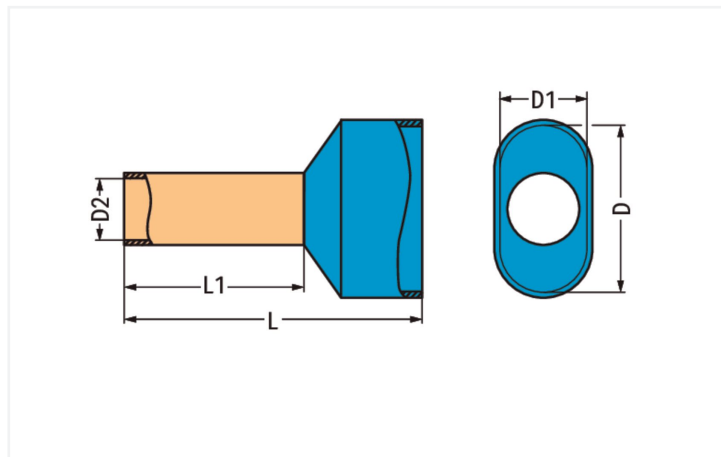

Color: ■ black

Similar to illustration

## Connection data

Fine-stranded conductor

1.5 mm<sup>2</sup> / 16 AWG

## Physical data

Length	20 mm
Crimp length (length of sleeve)	12 mm
Diameter	6.5 mm
Inner Diameter plastic collar	3.6 mm
Diameter crimp sleeve inside	2.2 mm

## Material data

Color	black
Fire load	0 MJ
Weight	0.2 g

## Commercial data

ETIM 8.0	EC000005
ETIM 7.0	EC000005
PU (SPU)	1000 pcs
Packaging type	Bag
Country of origin	DE
GTIN	4055143642811
Customs tariff number	85369010000

### Environmental Product Compliance

RoHS Compliance Status

Compliant, No Exemption

### Downloads

#### Environmental Product Compliance

##### Compliance Search

Environmental Product  
Compliance 216-1543



### Installation Notes

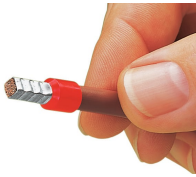

A perfect gas-tight crimp – both electrical-ly and mechanically reliable