

Data Sheet | Item Number: 216-142

Ferrule; Sleeve for 0.75 mm² / 18 AWG; uninsulated; electro-tin plated; electrolytic copper; gastight crimped; acc. to DIN 46228, Part 1/08.92

<https://www.wago.com/216-142>



Similar to illustration

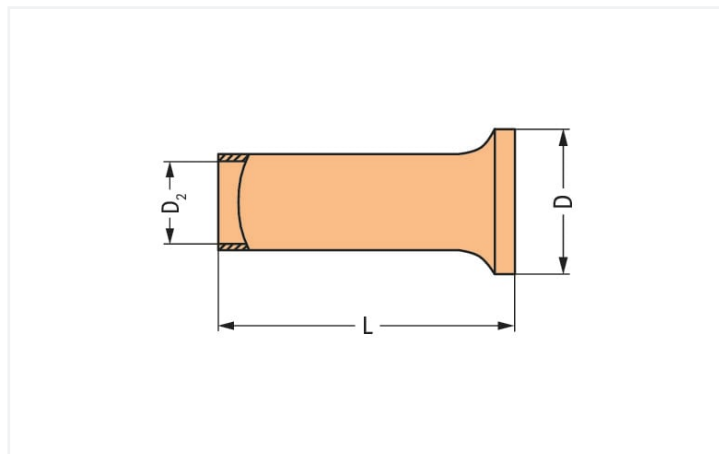

Dimensions in mm

Technical data

Sleeve cross-section (AWG)	18 AWG
Sleeve for	0.75 mm ²

Connection data

Strip length	10 mm / 0.39 inches
--------------	---------------------

Physical data

Length	10 mm
Diameter	2.3 mm
Diameter crimp sleeve inside	1.2 mm

Material data

Fire load	0 MJ
Weight	0.1 g

Commercial data

Product Group	2 (Terminal Block Accessories)
eCl@ss 10.0	27-40-02-01
eCl@ss 9.0	27-40-02-01
ETIM 8.0	EC000005
ETIM 7.0	EC000005
PU (SPU)	5000 (1000) pcs
Packaging type	Box
Country of origin	DE
GTIN	4044918016360
Customs tariff number	85369010000

Environmental Product Compliance	
RoHS Compliance Status	Compliant, No Exemption

Downloads

Environmental Product Compliance

Compliance Search	
Environmental Product Compliance 216-142	↓

Documentation

Bid Text			
216-142	19.02.2019	xml 2.87 KB	↓
216-142	13.06.2017	doc 23.00 KB	↓

Installation Notes

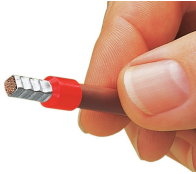

A perfect gas-tight crimp – both electrically and mechanically reliable