

MATERIALEN

Nummer	Omschrijving	Materiaal
1	Gevlochten slang	TPSiV- AISI 304
2	Pershuls	AISI 304
3	Tule	CW 617 N-DW UNI EN 12164
4	Dichting	EPDM
5	Wartel	CW 617 N UNI EN 12165
6	Fitting	CW617N-DW UNI EN 12164
7	Klemmoer	CW 614 N UNI EN 12164
8	Klemring	CW 614N-DW UNI EN 12164



TECHNISCHE GEGEVENS

Algemeen

Maximale druk	10 bar
Maximale bedrijfstemperatuur	70°C
Gewicht	86,1 Gram
Lengte (L)	1000 mm
Tolerantie (L)	30 mm

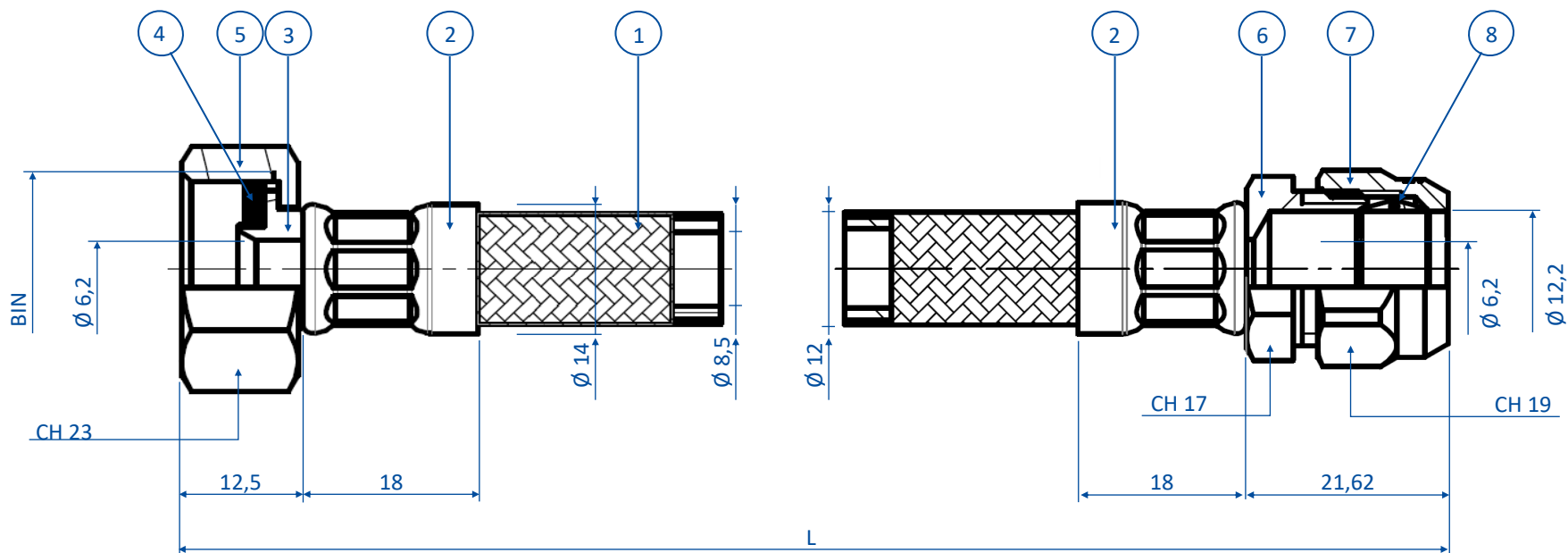

CH = Steeksleutelmaat