

Communicative linear actuator adjusting dampers and slide valves in technical building installations

- Actuating force 150 N
- Nominal voltage AC/DC 24 V
- Control modulating, communicative 2...10 V variable
- Position feedback 2...10 V variable
- Length of Stroke Max. 60 mm, adjustable in 20 mm increments
- Communication via Belimo MP-Bus
- Conversion of sensor signals

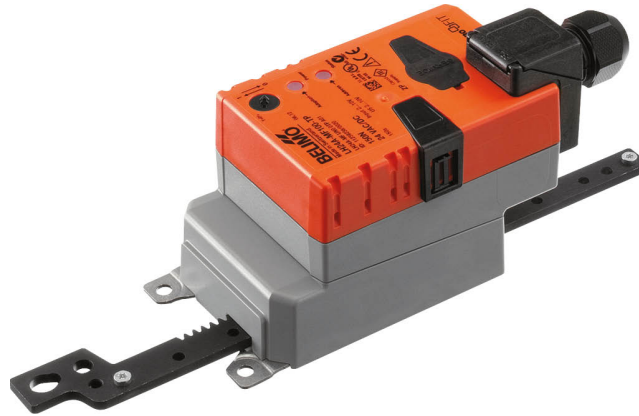

Technical data

| | | |
|-------------------------------|------------------------------------|---|
| Electrical data | Nominal voltage | AC/DC 24 V |
| | Nominal voltage frequency | 50/60 Hz |
| | Nominal voltage range | AC 19.2...28.8 V / DC 21.6...28.8 V |
| | Power consumption in operation | 2.5 W |
| | Power consumption in rest position | 1.2 W |
| | Power consumption for wire sizing | 5 VA |
| | Connection supply / control | Terminals 4 mm ² (cable ø4...10 mm, 4-wire) |
| | Parallel operation | Yes (note the performance data) |
| Data bus communication | Communicative control | MP-Bus |
| | Number of nodes | MP-Bus max. 8 |
| Functional data | Actuating force motor | 150 N |
| | Actuating force variable | 25%, 50%, 75% reduced |
| | Operating range Y | 2...10 V |
| | Input impedance | 100 kΩ |
| | Operating range Y variable | Start point 0.5...30 V End point 2.5...32 V |
| | Operating modes optional | Open/close 3-point (AC only) Modulating (DC 0...32 V) |
| | Position feedback U | 2...10 V |
| | Position feedback U note | Max. 0.5 mA |
| | Position feedback U variable | Start point 0.5...8 V End point 2.5...10 V |
| | Position accuracy | ±5% |
| | Direction of motion motor | selectable with switch |
| | Direction of motion note | Y = 0 V: with switch 0 (retracted) / 1 (extended) |
| | Direction of motion variable | electronically reversible |
| | Manual override | with push-button, can be locked |
| | Stroke | 60 mm |
| | Length of Stroke | Max. 60 mm, adjustable in 20 mm increments |
| | Stroke limitation | can be limited on both sides with mechanical end stops |
| | Running time motor | 150 s / 100 mm |
| Running time motor note | corresponds to 90 s / 60 mm | |
| Running time motor variable | 70...270 s / 100 mm | |
| Adaptation setting range | manual | |

Technical data

| | | |
|------------------------|--|---|
| Functional data | Adaptation setting range variable | No action Adaptation when switched on Adaptation after pushing the manual override button |
| | Override control | MAX (maximum position) = 100% MIN (minimum position) = 0% ZS (intermediate position, AC only) = 50% |
| | Override control variable | MAX = (MIN + 32%)...100% MIN = 0%...(MAX - 32%) ZS = MIN...MAX |
| | Sound power level, motor | 45 dB(A) |
| Safety data | Protection class IEC/EN | III, Safety Extra-Low Voltage (SELV) |
| | Power source UL | Class 2 Supply |
| | Degree of protection IEC/EN | IP54 |
| | Degree of protection NEMA/UL | NEMA 2 |
| | Enclosure | UL Enclosure Type 2 |
| | EMC | CE according to 2014/30/EU |
| | Certification IEC/EN | IEC/EN 60730-1 and IEC/EN 60730-2-14 |
| | UL Approval | cULus according to UL60730-1A, UL60730-2-14 and CAN/CSA E60730-1 The UL marking on the actuator depends on the production site, the device is UL-compliant in any case |
| | Hygiene test | According to VDI 6022 Part 1 / SWKI VA 104-01, cleanable and disinfected, low emission |
| | Type of action | Type 1 |
| | Rated impulse voltage supply / control | 0.8 kV |
| | Pollution degree | 3 |
| | Ambient humidity | Max. 95% RH, non-condensing |
| | Ambient temperature | -30...50°C [-22...122°F] |
| Storage temperature | -40...80°C [-40...176°F] | |
| Servicing | maintenance-free | |
| Weight | Weight | 0.46 kg |

Safety notes



- This device has been designed for use in stationary heating, ventilation and air-conditioning systems and must not be used outside the specified field of application, especially in aircraft or in any other airborne means of transport.
- Outdoor application: only possible in case that no (sea) water, snow, ice, insolation or aggressive gases interfere directly with the device and that it is ensured that the ambient conditions remain within the thresholds according to the data sheet at any time.
- Only authorised specialists may carry out installation. All applicable legal or institutional installation regulations must be complied with during installation.
- The device may only be opened at the manufacturer's site. It does not contain any parts that can be replaced or repaired by the user.
- The rotary supports and coupling pieces available as accessories must always be used if transverse forces are likely. In addition, the actuator must not be tightly bolted to the application. It must remain movable via the rotary support (refer to «Installation notes»).
- If the actuator is exposed to severely contaminated ambient air, appropriate precautions must be taken on the system side. Excessive deposits of dust, soot etc. can prevent the gear rod from being extended and retracted correctly.
- If not installed horizontally, the manual override button may only be actuated when there is no pressure on the gear rod.
- To calculate the actuating force required for air dampers and slide valves, the specifications supplied by the damper manufacturers concerning the cross-section and the design, as well as the installation situation and the ventilation conditions must be observed.
- If a rotary support and/or coupling piece is used, actuation force losses are to be expected.
- The device contains electrical and electronic components and must not be disposed of as household refuse. All locally valid regulations and requirements must be observed.

Product features

| | |
|---------------------------------|---|
| Operating mode | <p>Conventional operation:</p> <p>The actuator is connected with a standard control signal of 0...10 V and drives to the position defined by the control signal. Measuring voltage U serves for the electrical display of the damper position 0...100% and as control signal for other actuators.</p> <p>Operation on Bus:</p> <p>The actuator receives its digital control signal from the higher level controller via the MP-Bus and drives to the position defined. Connection U serves as communication interface and does not supply an analogue measuring voltage.</p> <p>The actuator has a seal closing function. The mechanical end stop is actively approached as soon as the control signal < DC 2.1 V or > DC 9.9 V. As soon as the control signal is again > DC 2.2 V or < DC 9.8 V, the actuator drives to the position defined by the control signal in the adapted range.</p> |
| Converter for sensors | <p>Connection option for a sensor (passive or active sensor or switching contact). The MP actuator serves as an analogue/digital converter for the transmission of the sensor signal via MP-Bus to the higher level system.</p> |
| Parametrisable actuators | <p>The factory settings cover the most common applications. Single parameters can be modified with the Belimo service tools MFT-P or ZTH EU.</p> |
| Simple direct mounting | <p>The actuator can be directly connected with the application using the enclosed screws. The head of the gear rod is connected to the moving part of the ventilating application individually on the mounting side or with the Z-KS2 coupling piece provided.</p> |
| Manual override | <p>Manual override with push-button possible (the gear train is disengaged for as long as the button is pressed or remains locked).</p> |
| Adjustable stroke | <p>If a stroke limitation will be adjusted, the mechanical operating range on this side of the gear rod can be used starting with an extension length of 20 mm and then can be limited respectively in increments of 20 mm by means of mechanical end stops Z-AS2.</p> |

Product features

- High functional reliability** The actuator is overload protected, requires no limit switches in intermediate positions and automatically stops when the end stop is reached (at rest).
- Home position** The first time the supply voltage is switched on, i.e. at the time of commissioning, the actuator carries out a synchronisation. The synchronisation is in the home position (0%).
The actuator then moves into the position defined by the control signal.

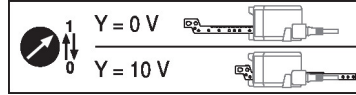

- Adaptation and synchronisation** An adaptation can be triggered manually by pressing the "Adaptation" button or with the PC-Tool. Both mechanical end stops are detected during the adaptation (entire setting range). Automatic synchronisation after pressing the manual override button is configured. The synchronisation is in the home position (0%).
The actuator then moves into the position defined by the control signal.
A range of settings can be adapted using the PC-Tool (see MFT-P documentation)

Accessories

| Gateways | Description | Type |
|------------------------|---|------------|
| | Gateway MP to BACnet MS/TP | UK24BAC |
| | Gateway MP to Modbus RTU | UK24MOD |
| Electrical accessories | Description | Type |
| | Signal converter voltage/current 100 kΩ 4...20 mA, Supply AC/DC 24 V | Z-UIC |
| | Positioner for wall mounting | SGA24 |
| | Positioner for built-in mounting | SGE24 |
| | Positioner for front-panel mounting | SGF24 |
| | Positioner for wall mounting | CRP24-B1 |
| | MP-Bus power supply for MP actuators | ZN230-24MP |
| Mechanical accessories | Description | Type |
| | End stop kit, Multipack 20 pcs. | Z-AS2 |
| | Rotary support, for linear actuator, for compensation of transverse forces | Z-DS1 |
| | Coupling piece M6 | Z-KS2 |
| | Terminal protection IP54, Multipack 20 pcs. | Z-TP |
| Tools | Description | Type |
| | Service tool, with ZIP-USB function, for parametrisable and communicative Belimo actuators, VAV controller and HVAC performance devices | ZTH EU |
| | Belimo PC-Tool, Software for adjustments and diagnostics | MFT-P |
| | Adapter for Service-Tool ZTH | MFT-C |
| | Connecting cable 5 m, A: RJ11 6/4 ZTH EU, B: 6-pin for connection to service socket | ZK1-GEN |
| | Connecting cable 5 m, A: RJ11 6/4 ZTH EU, B: free wire end for connection to MP/PP terminal | ZK2-GEN |

Electrical installation

- Supply from isolating transformer.**
Parallel connection of other actuators possible. Observe the performance data.

Electrical installation

Wiring diagrams

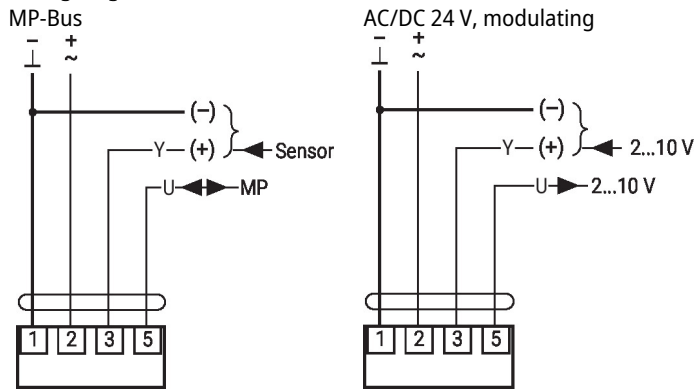

| | | | | |
|---|---|------|--|--|
| 1 | 2 | 3 | | |
| | | 2 V | | |
| | | 10 V | | |

Functions

Functions with basic values (conventional mode)

Override control with AC 24 V with relay contacts

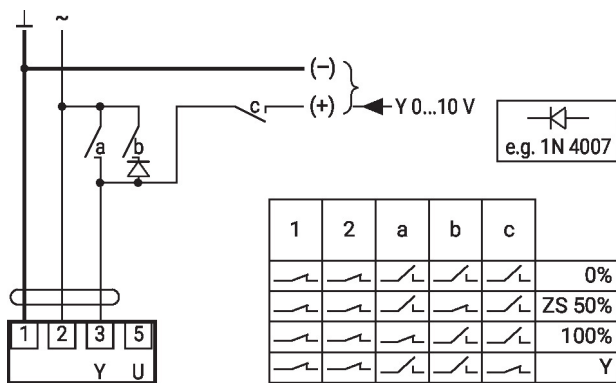

Override control with AC 24 V with rotary switch

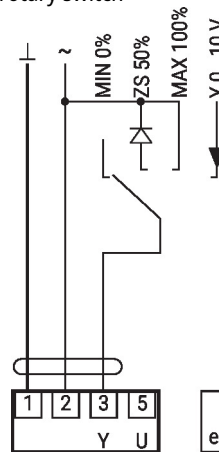

Control remotely 0...100% with positioner SG..

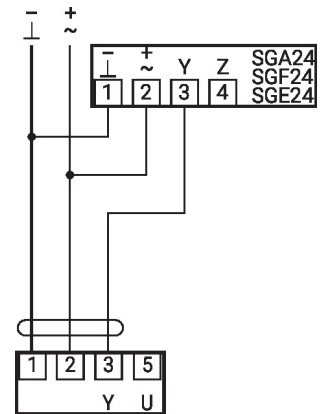

Minimum limit with positioner SG..

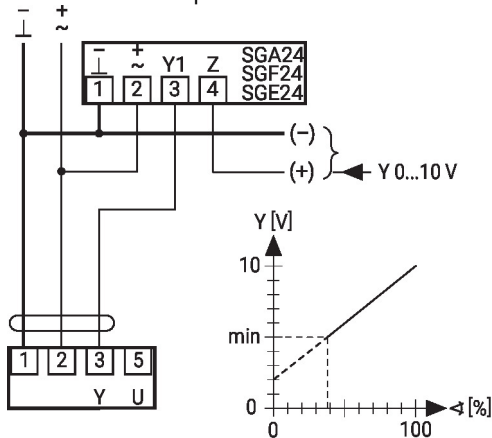

Primary/secondary operation (position-dependent)

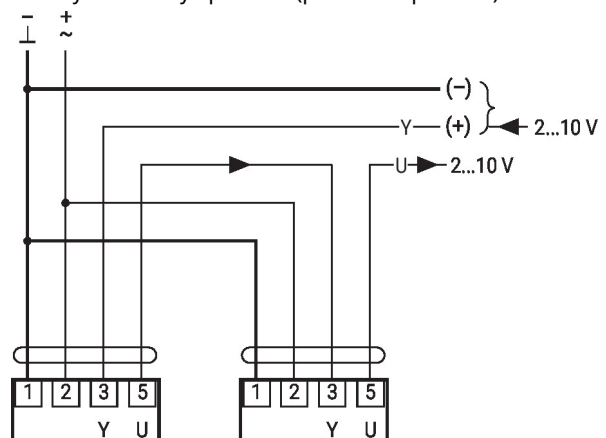

Functions with basic values (conventional mode)

Control with 4...20 mA via external resistor

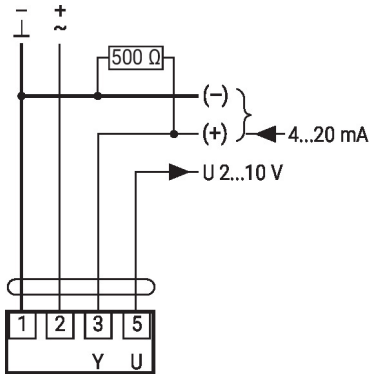

Caution:

The operating range must be set to DC 2...10 V.

The 500 Ohm resistor converts the 4...20 mA current signal to a voltage signal DC 2...10 V.

Functional check

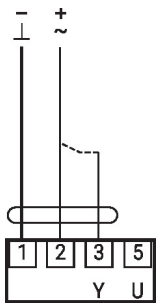

Procedure

1. Connect 24 V to connections 1 and 2
2. Disconnect connection 3:
 - with direction of rotation L: Actuator rotates to the left
 - with direction of rotation R: Actuator rotates to the right
3. Short-circuit connections 2 and 3:
 - Actuator runs in opposite direction

Functions with specific parameters (Parametrisation necessary)

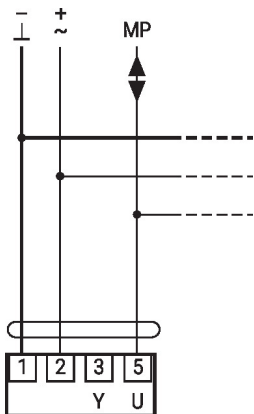

MP-Bus Network topology

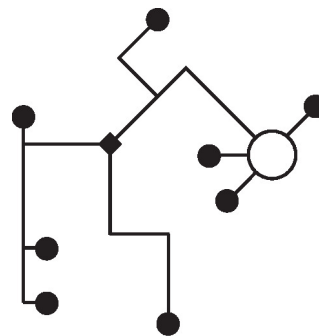

There are no restrictions for the network topology (star, ring, tree or mixed forms are permitted).

Supply and communication in one and the same 3-wire cable

- no shielding or twisting necessary
- no terminating resistors required

Max. 8 additional MP-Bus nodes

Functions with specific parameters (Parametrisation necessary)

Connection of active sensors

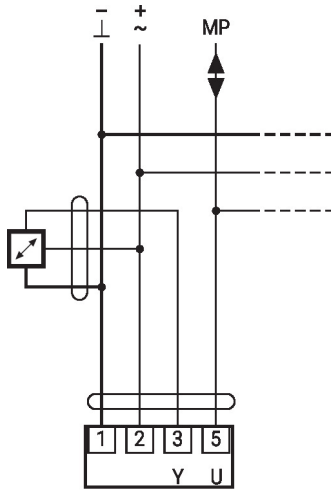

- Max. 8 additional MP-Bus nodes
- Supply AC/DC 24 V
 - Output signal 0...10 V (max. 0...32 V)
 - Resolution 30 mV

Connection of external switching contact

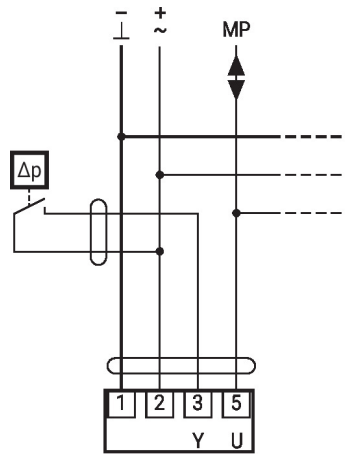

- Max. 8 additional MP-Bus nodes
- Switching current 16 mA @ 24 V
 - Start point of the operating range must be parametrised on the MP actuator as ≥ 0.5 V

Connection of passive sensors

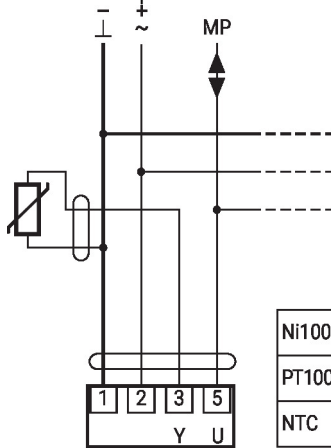

| | | |
|--------|----------------------------|---|
| Ni1000 | -28...+98°C | 850...1600 Ω ²⁾ |
| PT1000 | -35...+155°C | 850...1600 Ω ²⁾ |
| NTC | -10...+160°C ¹⁾ | 200 Ω ...60 k Ω ²⁾ |

- 1) Depending on the type
2) Resolution 1 Ohm
Compensation of the measured value is recommended

Override control and limiting with AC 24 V with relay contacts

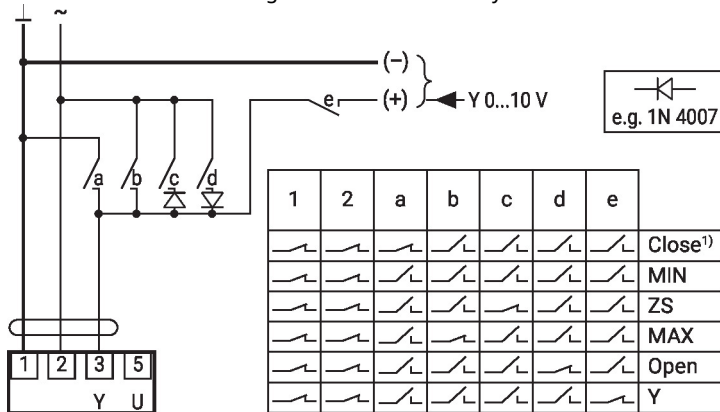

Control open/close

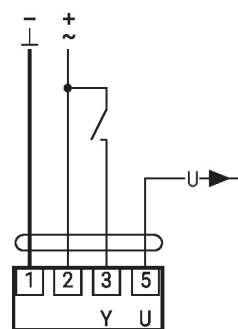

Functions

Functions with specific parameters (Parametrisation necessary)

Override control and limiting with AC 24 V with rotary switch

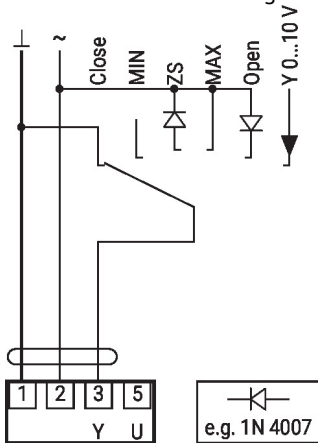

Control 3-point with AC 24 V

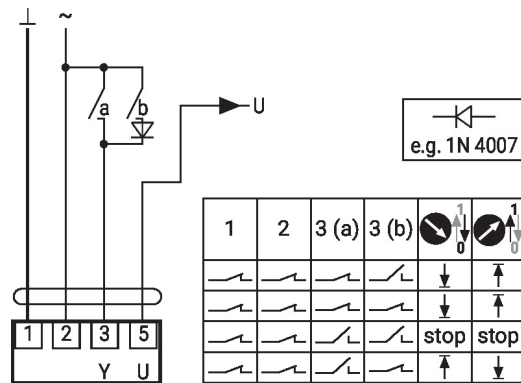

Caution:
The "Close" function is only guaranteed if the start point of the operating range is defined as min. 0.5 V.

Operating controls and indicators

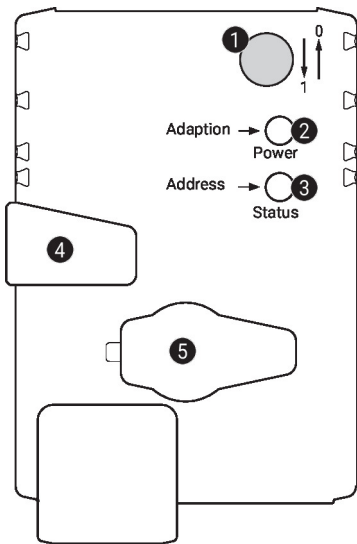

1 Direction of stroke switch

Switch over: Direction of stroke changes

2 Push-button and LED display green

Off: No power supply or malfunction
On: In operation
Press button: Triggers stroke adaptation, followed by standard mode

3 Push-button and LED display yellow

Off: Standard mode
On: Adaptation or synchronisation process active
Flickering: MP-Bus communication active
Flashing: Request for addressing from MP client
Press button: Confirmation of the addressing

4 Manual override button

Press button: Gear train disengages, motor stops, manual override possible
Release button: Gear train engages, synchronisation starts, followed by standard mode

5 Service plug

For connecting parametrisation and service tools

Check power supply connection

2 Off and **3** On Possible wiring error in power supply

Installation notes



If a rotary support and/or coupling piece is used, losses in the actuation force losses are to be expected.

Installation notes

Applications without transverse forces The linear actuator is screwed directly to the housing at three points. Afterwards, the head of the gear rod is fastened to the moving part of the ventilation application (e.g. damper or slide valve).

Applications with transverse forces Connect the coupling piece with the internal thread (Z-KS2) to the head of the gear rod. Screw the rotary support (Z-DS1) to the ventilation application. Afterwards, the linear actuator is screwed to the previously mounted rotary support with the enclosed screw. Then, the coupling piece, which is mounted to the head of the gear rod, is attached to the moving part of the ventilating application (e.g. damper or slide valve). The transverse forces can be compensated for to a certain limit with the rotary support and/or coupling piece. The maximum permissible swivel angle of the rotary support and coupling piece is 10°, laterally and upwards.

Service

Tool connection The actuator can be parametrised by ZTH EU via the service socket. For an extended parametrisation the PC tool can be connected.

Connection ZTH EU / PC-Tool

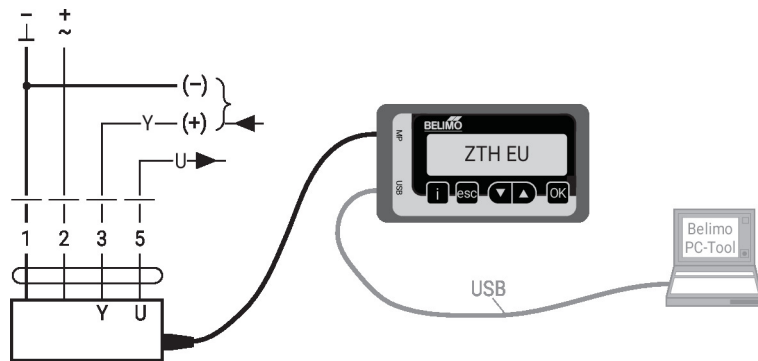

Dimensions

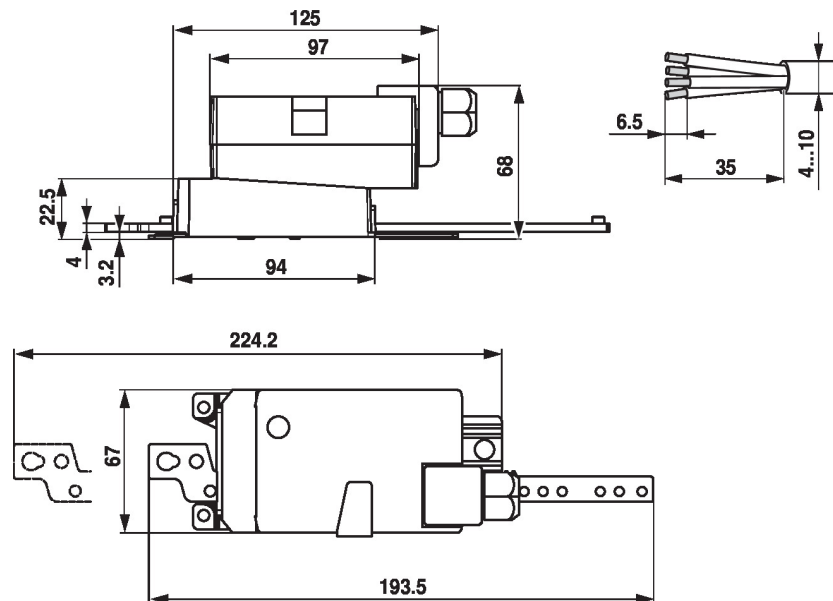

Further documentation

- Overview MP Cooperation Partners
- Tool connections
- Introduction to MP-Bus Technology

Application notes

- For digital control of actuators in VAV applications patent EP 3163399 must be considered.