

## Data Sheet | Item Number: 771-8992/005-105

pre-assembled interconnecting cable; Eca; Socket/plug; 2-pole; Cod. B; Control cable 2 x 1.0 mm<sup>2</sup>; 1 m; 1,00 mm<sup>2</sup>; light green

<https://www.wago.com/771-8992/005-105>



Color: ■ light green

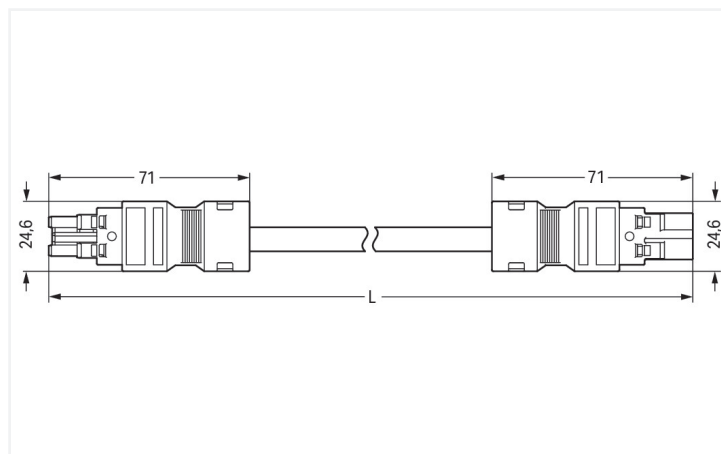

Dimensions in mm

Cable assembly *WINSTA*® MIDI with protection type IP20

Use effective pluggable connections instead of laborious screw connections: With the *WINSTA*® MIDI cable assembly with protection against mismatching. WAGO pluggable installation connectors are used when requirements repeat or are distributed on a specific pattern, for example for installing grid lighting or flush-mount lighting. The coding options reduce installation errors, allowing fast, maintenance-free wiring of all components. The pluggable installation connector is protected against ingress by solid objects in accordance with protection type IP20 (When mated: IP2xC (These compact connectors are not designed for use in open, easily accessible areas!)). Pluggable installation connectors with B coding from the *WINSTA*® MIDI line are available in gray, light green, or pink, allowing you to distinguish different circuits, for example for light, pumps or, sun blinds. Usage-specific pole marking is possible in addition. The *WINSTA*® MIDI Pluggable Connection System with Push-in CAGE CLAMP® spring pressure connection technology facilitates exemplary electrification. Thanks to the built-in test slot, connections can be checked even when they are plugged in. This saves time, labor, and money. This product meets all the relevant safety requirements of fire class E; therefore it can be used in domains where fire safety is relevant.

Fast, error-free assembly thanks to cable assemblies from WAGO

A socket and a plug are available. *WINSTA*® is the pluggable connection system that is perfectly tailored to the strict requirements of electrical installation. It allows error-free installation of cables and components, quickly and reliably. Choose quality and durability – with marking from WAGO makes the electrical installation of electrical components noticeably easier.

- protection against mismatching eliminates errors
- simple circuits
- for automation controllers
- ready to install and use immediately
- quick replacement of defective units during ongoing operation

### Notes

Note

Cables with a different fire class can be found in the eShop.

Variants:

Other pole markings

Other versions (or variants) can be requested from WAGO Sales or configured at <https://configurator.wago.com/>.

## Electrical data

Ratings per	IEC/EN 60664-1		
Overvoltage category	III	III	II
Pollution degree	3	2	2
Nominal voltage	250 V	-	-
Rated impulse withstand voltage	4 kV	-	-
Rated current	10 A	-	-

## General information

Note on contact resistance	approx. 1 mΩ of contact resistance approx. 0.25 mΩ contact transition plug/ socket
----------------------------	--

## Connection Data

Total number of potentials	2
----------------------------	---

## Connection 1

Pole number	2
Wire cross-section	1 mm <sup>2</sup>
Connection type	Socket - Plug

## Physical data

Pin spacing	10 mm / 0.394 inches
Width	24.6 mm / 0.969 inches
Total length	1 m

## Mechanical data

Use	Control technology
Coding	B
Variable coding	No
Marking	1 2
Potential marking	1 2
Mating force of a plug-in connection	approx. 20 ... 70 N (depending on pole number)
Retention force of a plug-in connection	when locked: > 80N
Unmating force of a plug-in connection	when unlocked: approx. 20 ... 70 N (depending on pole number)
Number of mating cycles	200, without resistive load
Connection type	Socket - Plug
Type of pre-assembled cable	Interconnecting cable
Cable type	Control line 2x1
Protection type	IP20; When mated: IP2xC (These compact connectors are not designed for use in open, easily accessible areas!)

## Plug-in connection

Mismating protection	Yes
Note on mismating protection	All <i>WINSTA</i> ® components are 100% protected against mismating when: a.) plugging different numbers of poles b.) plugging while rotated 180 c.) plugging while laterally staggered d.) plugging one pole
Locking lever	Can be retrofitted
Locking of plug-in connection	Locking lever
Note on locking system	All connectors for mounted installations (snap-in versions for lighting fixtures or devices, all types of PCB and distribution connectors) are factory-equipped with locking levers to ensure plugs and sockets are securely locked. Additional locking levers are only required for flying leads (plug/socket).

### Material data

Note (material data)	<a href="#">Information on material specifications can be found here</a>
Color	light green
Insulation material (main housing)	Polyamide (PA66)
Fire class per EN 50575	E <sub>ca</sub>
Contact material	Copper or copper alloy; surface-treated
Contact Plating	Tin
Fire load	0.629 MJ
Connector color	light green
Strain relief color	black
Sheathed cable color	gray
Printing color of sheathed cable	black
Halogen-free	No
Silicon-free	Yes
Sheath material	PVC
Rubber cable	No
Weight	71 g
Copper weight of the raw cable	0.0192 kg/m

### Environmental requirements

Processing temperature	-5 ... +40 °C
Continuous operating temperature	-35 ... +85 °C
Note on continuous operating temperature	Cable for temperatures ≤ 70 °C (including halogen-free) Insulating parts for temperatures ≤ 105 °C

### Commercial data

PU (SPU)	1 pcs
Packaging type	unpacked
Country of origin	DE
GTIN	4055143370479
Customs tariff number	85444290900

### Product Classification

UNSPSC	26121629
eCl@ss 10.0	27-44-06-04
eCl@ss 9.0	27-44-06-04
ETIM 9.0	EC002587
ETIM 10.0	EC002587
ECCN	NO US CLASSIFICATION

### Environmental Product Compliance

RoHS Compliance Status	Compliant, No Exemption
------------------------	-------------------------

## Downloads

### Environmental Product Compliance

#### Compliance Search

Environmental Product Compliance  
771-8992/005-105



## Documentation

### Bid Text

771-8992/005-105	19.02.2019	xml 2.92 KB	
771-8992/005-105	02.06.2015	doc 25.00 KB	

## CAD/CAE-Data

### CAE data

EPLAN Data Portal  
771-8992/005-105



## 1 Compatible Products

### 1.1 Required Accessories

#### 1.1.1 Locking system

##### 1.1.1.1 Locking system



**Item No.: 770-101**

Locking lever; for flying leads; for manual operation; black

**Item No.: 770-121**

Locking lever; for flying leads; for manual operation; white

**Item No.: 770-111**

Locking lever; for flying leads; for tool operation; black

**Item No.: 770-131**

Locking lever; for flying leads; for tool operation; white

### 1.2 Optional Accessories

#### 1.2.1 Cover

##### 1.2.1.1 Cover



**Item No.: 770-201**

Lockout cap; 12-pole, separable; for sockets; Plastic; black

**Item No.: 770-221**

Lockout cap; 12-pole, separable; for sockets; Plastic; white

**Item No.: 770-360**

Lockout cap; for plugs; 5-pole; separable; yellow

**Item No.: 897-2003**

Protective cap; Type2; for sockets and plugs; PVC; red

## 1.2.2 Installation

### 1.2.2.1 Mounting accessories



**Item No.: 770-310**

Mounting carrier; 2- to 5-pole; for flying leads; black

## 1.2.3 Marking

### 1.2.3.1 Marking strip



**Item No.: 210-334**

Marking strips; as a DIN A4 sheet; Strip width 5 mm; Strip length 182 mm; plain; Self-adhesive; white