

## PRODUCT PROFILE



## SPECIFICATIONS

- Display : Liquid crystal display with backlight 1 line, 4 digits and 2 lines with 7 digits per line to show electrical parameters
- LCD Indications : **MD** - Communication in progress  
**MD** - Maximum & Minimum Demand of Power
- LED Indication : **INT** - Integration of energy
- Wiring Input : 3 Ø - 4 wire, 1 Ø - 2 wire, 3 Ø - 3 wire
- Rated Input Voltage : 3x230/400V
- Installation Category : III (300V L-N)
- Frequency Range : 47-63 Hz
- CT Primary : 1/5A to 6,000A (Programmable for any Value)
- CT Secondary : 1 or 5A
- PT Primary : 100V to 600V (Programmable for any value)
- PT Secondary : 173 to 415V AC (L-L) (Programmable for any value)
- Display Update Time : 1 sec for all parameters
- Display Scrolling : Automatic / Manual
- Auxiliary : 85 to 270V AC, 47/63Hz
- Temperature : Operating: -10°C to 55°C  
Storage : -20°C to 75°C
- Humidity : 85% non-condensing
- Mounting : DIN rail mounting
- Meter Type : Indoor
- Weight : 215g
- IP rating : Ip51 (Front of housing only - this device must be installed within a suitable IP rated enclosure)
- Output : RS485 (Modbus RTU)
- The meter is intended to be installed in Mechanical Environment `M1`, with Shock and Vibrations of low significance, as per 2004/22/EC Directive.
- The meter is intended to be installed in Electromagnetic Environment `E2`, as per 2004/22/EC Directive.

## ORDER INFORMATION

Product	Outputs	Certification	
EMC3P-D2C1	RS485 (Modbus RTU)	CE	MID

## SERIAL COMMUNICATION

Interface standard and protocol	RS485 AND MODBUS RTU
Communication address	1 to 255
Transmission Mode	Half duplex
Data types	Float, Hex and Integer
Transmission distance	500 Meter maximum
Transmission speed	300, 600, 1200, 2400, 4800, 9600, 19200 (in bps)
Parity	None, Odd, Even
Stop bits	1 or 2
Response time	100 ms (max and independent of baud rate)

## ACCURACY

Measurement	Accuracy	Measurement	Accuracy
Voltage $V_{LN}$	±0.5% of F.S.	Power factor	±0.01 (Digit)
Voltage $V_{LL}$	±0.5% of F.S.	Active energy	EN50470-3: Cl.B
Current	±0.5% of F.S.	Reactive energy	EN62053-23: Cl.2
Frequency	±0.1% of F.S.	Apparent energy	Class 1
For L-N > 20V, For L-L > 35V		MAX/MIN Active Power	1%
Active Power	1%	MAX/MIN Reactive Power	1%
Apparent power	1%	MAX Apparent Power	1%
Reactive Power	1%		

## NOTE :

**TO COMPLY WITH MID CERTIFICATION THE CT RATIO MUST BE SET BEFORE PUTTING THE METER INTO SERVICE**

## CONFIGURATION LOCK PARAMETER DESCRIPTION

**When the configuration mode is entered and any of the parameters are changed the user has only 15 minutes to make changes. After this time the parameters below are locked and cannot be changed. The meter can only be unlocked by returning it to the factory for the lock out.**

**PARAMETERS ARE :**

<b>Network Selection</b>	<b>PT secondary</b>
<b>CT Primary</b>	<b>CT Secondary</b>
<b>PT Primary</b>	<b>Factory default</b>
<b>Energy Reset</b>	

## RESOLUTION

PT Ratio x CT Ratio	kWh	Pulse LED
<15	0.01K	0.001K
<150	0.1K	0.01K
<1500	1K	0.1K
<15000	0.01M	0.001M
>15000	0.1M	0.01M

## SAFETY PRECAUTIONS

Safety related notifications, symbols and instructions that appear in this operating manual or on the equipment must be strictly followed to ensure the safety of personnel as well as the instrument.

If the equipment is not used in a manner specified by the manufacturer it may impair the protection provided by the equipment.

- ⚠ Do not use the equipment if there is any mechanical damage.
- ⚠ Ensure that the equipment is supplied with correct voltage.
- ⚠ No repairs, maintenance or adjustments are possible.

## CAUTION

1. Read complete instructions prior to installation or operation of the unit.
2. Risk of electric shock. Only to be installed by competent personnel.
3. The equipment in its installed state must not come in close proximity to any heating sources, oils, steam, caustic vapors or other unwanted process by-products.

## WIRING GUIDELINES

1. To prevent the risk of electrocution, always isolate the power supply to the equipment prior to undertaking any work. Always confirm absence of supply prior to starting work using appropriate voltage detection equipment.
2. Wiring shall be done strictly according to the terminal layout. Confirm that all connections are correct before energizing the equipment.
3. To reduce electromagnetic interference use of wires with adequate ratings and twists of equal size are recommended. All connection should be kept as short as possible.
4. Routing of connecting cables shall be away from any internal EMI source.
5. All cables used for connections must have a cross section of 0.5mm<sup>2</sup> to 2.5mm<sup>2</sup>. (20 to 14AWG; 75°C (min) )
6. Copper cable should be used. (stranded or solid core cable)
7. All wiring to be in accordance with applicable local standards.

FRONT PANEL DESCRIPTION

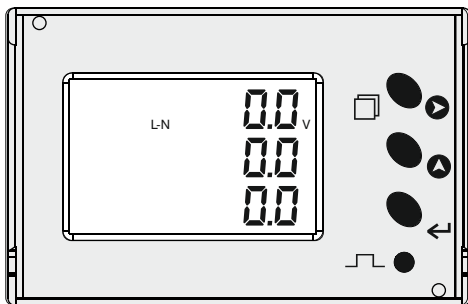

CONFIGURATION

There are 3 dedicated key with symbols marked as **▶**, **▲** and **◀**. Use these 3 key to enter into configuration / change setting.  
**Note** : Programming should be performed by a professional. Programming should only be attempted after having read through this users manual thoroughly.  
 For the configuration setting mode :  
 • Use **▶** and **◀** for 3 sec. to enter or exit from config. mode.  
 • Use **▶** shift key to move cursor left or right by one digit each time. After last digit of display cursor shift at 1st digit of display.  
 • Use **▲** increment key for increasing the parameter value.  
 • Use **◀** key to save the setting and move on to next page.  
 • Use **▶** and **▶** keys to go back to previous page.

For 3P4W and 3P3W

KEY PRESS	PARAMETER KEY	DESCRIPTION
Press page (▶) key (1st time)	— (Page 1)	Displays line to neutral
	Press ▲ key (Page 2)	Displays line to line voltage of three phases (★)
Press page (▶) key (2nd time)	— (Page 3)	Displays phase current of three phases (★)
	Press ▲ key (Page 4)	Displays average line to neutral voltage, current and power factor of three phases and frequency.
Press page (▶) key (3rd time)	Press ▲ key (Page 5)	Displays average line to line voltage, current and power factor of three phases and frequency. (★)
	— (Page 6)	Displays power factor of three phases and frequency.
Press page (▶) key (4th time)	Press ▲ key 1st time (Page 7)	Displays active power of three phases.
	Press ▲ key 2nd time (Page 8)	Displays reactive power of three phases.
	Press ▲ key 3rd time (Page 9)	Displays apparent power of three phases.
	Press ▲ key 4th time (Page 10)	Displays total active power of three phases. (★)
	Press ▲ key 5th time (Page 11)	Displays total reactive power of three phases. (★)
	Press ▲ key 6th time (Page 12)	Displays total apparent power of three phases. (★)
	Press ▲ key 7th time (Page 13)	Display MAX(2nd row) and MIN(3rd row) demand of total active power (★)
	Press ▲ key 8th time (Page 14)	Display MAX(2nd row) and MIN (3rd row) demand of total reactive power (★)
	Press ▲ key 9th time (Page 15)	Display MAX demand of total apparent power (★)
	Press page (▶) key	— (Page 16)
Press ▲ key 1st time (Page 17)		Displays average voltage line to neutral (1st row) and Import (2nd row) and export (3rd row) reactive energy of three phases. (★)
Press ▲ key 2nd time (Page 18)		Displays average voltage line to neutral (1st row) and apparent energy (3rd row) of three phases. (★)
For this key function in 1st row for 3P3W voltage will be average line to line.		

For 1P2W - P1

KEY PRESS	PARAMETER KEY	DESCRIPTION
Press page (▶) key (1st time)	— (Page 1)	Displays line to neutral voltage of selected phase.
	— (Page 3)	Displays phase current of selected phase.
Press page (▶) key (2nd time)	— (Page 6)	Displays power factor of selected phase and
	Press ▲ key 1st time (Page 7)	Displays active power of selected phase.
Press page (▶) key (4th time)	Press ▲ key 2nd time (Page 8)	Displays reactive power of selected phase.
	Press ▲ key 3rd time (Page 9)	Displays apparent power of selected phase.
	Press ▲ key 7th time (Page 13)	Display MAX(2nd row) and MIN(3rd row) demand of total active power.
	Press ▲ key 8th time (Page 14)	Display MAX(2nd row) and MIN (3rd row) demand of total reactive power.
Press page (▶) key	Press ▲ key 9th time (Page 15)	Display MAX demand of total apparent power.
	— (Page 16)	Displays average voltage line to neutral (1st row) and Import (2nd row) and export (3rd row) active energy of
	Press ▲ key 1st time (Page 17)	Displays average voltage line to neutral (1st row) and Import (2nd row) and export (3rd row) reactive energy of selected phase.
Press page (▶) key	Press ▲ key 2nd time (Page 18)	Displays average voltage line to neutral (1st row) and apparent energy (3rd row) of selected phase.
	<b>Note</b> : For 1 phase 2 wire network, only selected phase Parameter will display.	

PRODUCT DESCRIPTION

Press **▲** key for 10 sec to display the 8 digit serial number only 10 sec. on the 2nd and 3rd line of the display. With the serial number displayed press **▶** key once to display product name on 1st row, software version on 2nd row & CRC count on 3rd row.

AUTO / MANUAL / DEFAULT PAGE MODE DESCRIPTION :

Press **◀** key for 3sec. to change the on-line page mode. The sequence will be Auto / Manual / Default

Config. page.	Function	Range or Selection	Factory Setting
	Password	0000 to 9998	1000
1	Change Password	No / Yes	No
1.1	New Password	0000 to 9998	1000
2	Network Selection	3P4W, 3P3W, 1P2W-P1.	3P4W
3	CT Secondary	1 or 5	5
4	CT Primary	5A to 6,000A	5
5	PT Secondary	100V to 500V	350
6	PT primary	100V to 600V	350
7	Slave Id	1 to 255	1
8	Baud Rate	300, 600, 1200, 2400, 4800, 9600 and 19200	9600
9	Parity	None, Even, Odd	None
10	Stop Bit	1 or 2	1
11	Back Light	0 to 7200 sec.	0000
12	Demand interval method	Sliding / Fixed	Sliding
13	Demand interval duration	1 to 30	15
14	Demand interval length	1 to 30min	1
15	Max auto Pages	1 to 18	18
16	Change Page Sequence	No / Yes	No
16.1	Page Sequence 1	01 to 18	1
16.2	Page Sequence 2	01 to 18	2
16.3	Page Sequence 3	01 to 18	3
16.4	Page Sequence 4	01 to 18	4
16.5	Page Sequence 5	01 to 18	5
16.6	Page Sequence 6	01 to 18	6
16.7	Page Sequence 7	01 to 18	7
16.8	Page Sequence 8	01 to 18	8
16.9	Page Sequence 9	01 to 18	9
16.10	Page Sequence 10	01 to 18	10
16.11	Page Sequence 11	01 to 18	11
16.12	Page Sequence 12	01 to 18	12
16.13	Page Sequence 13	01 to 18	13
16.14	Page Sequence 14	01 to 18	14
16.15	Page Sequence 15	01 to 18	15
16.16	Page Sequence 16	01 to 18	16
16.17	Page Sequence 17	01 to 18	17
16.18	Page Sequence 18	01 to 18	18
17	Factory Default	No / Yes	No
18	Reset Energy and MAX Demand	No / Yes	No
18.1	Password	0001 to 9999	1001
18.01	Reset Active Energy	No / Yes	No
18.02	Reset Reactive Energy	No / Yes	No
18.03	Reset Apparent Energy	No / Yes	No
18.04	Reset MAX Power	No / Yes	No

• For resetting energy parameters user will be prompted for the password. If correct password is entered, the user will be able to reset all energy parameters. This password will be greater than the configuration password by 1.

## MODBUS REGISTER ADDRESSES LIST

Readable / writable parameters : ( Data Structure Interger)					
Address	Hex Address	Parameter	Range		Length (Register)
40000	0x00	Password	Min value : 0	Max value : 9998	
40001	0x01	N/W selection	Value : 0x0000	Meaning : 3P-4W	1
			Value : 0x0001	Meaning : 3P-3W	1
			Value : 0x0002	Meaning : 1P2W-P1	1
40002	0x02	CT Secondary (A)	Min value : 1	Max value : 5	1
40003	0x03	CT primary(CT Secondary=1)(A)	Min value : 1	Max value : 10000	1
		CT primary(CT Secondary=5)(A)	Min value : 5	Max value : 10000	1
40004	0x04	PT Secondary (V)	Min value : 100	Max value : 500	1
40005	0x05	PT primary (V)	Min value : 100	Max value : 500kV	2
40007	0x07	Slave id	Min value : 1	Max value : 255	1
40009	0x09	Parity	Value: 0x0000	Meaning : None	1
			Value: 0x0001	Meaning : Odd	
			Value: 0x0002	Meaning : Even	
40010	0x0A	Stop bit	Value: 0x0000	Meaning : 1	1
			Value: 0x0001	Meaning : 2	
40011	0x0B	Backlight OFF (sec.)	Min Value : 0	Max Value : 7200	1
40012	0x0C	Factory Default	1	Set to factory setting range	1
40013	0x0D	Reset kWh	1	Reset total active energy	1
40014	0x0E	Reset kWh	1	Reset total apparent energy	1
40015	0x0F	Reset kWh	1	Reset total reactive energy	1
40016	0x10	Auto mode sequence	Min value : 1	Max value : 18	1
40017	0x11	Page address sequence 1	Page No.: 1-18	Meaning: 1-First page ; 18-Last page	1
40018	0x12	Page address sequence 2	Page No.: 1-18	Meaning: 1-First page ; 18-Last page	1
40019	0x13	Page address sequence 3	Page No.: 1-18	Meaning: 1-First page ; 18-Last page	1
40020	0x14	Page address sequence 4	Page No.: 1-18	Meaning: 1-First page ; 18-Last page	1
40021	0x15	Page address sequence 5	Page No.: 1-18	Meaning: 1-First page ; 18-Last page	1
40022	0x16	Page address sequence 6	Page No.: 1-18	Meaning: 1-First page ; 18-Last page	1
40023	0x17	Page address sequence 7	Page No.: 1-18	Meaning: 1-First page ; 18-Last page	1
40024	0x18	Page address sequence 8	Page No.: 1-18	Meaning: 1-First page ; 18-Last page	1
40025	0x19	Page address sequence 9	Page No.: 1-18	Meaning: 1-First page ; 18-Last page	1
40026	0x1A	Page address sequence 10	Page No.: 1-18	Meaning: 1-First page ; 18-Last page	1
40027	0x1B	Page address sequence 11	Page No.: 1-18	Meaning: 1-First page ; 18-Last page	1
40028	0x1C	Page address sequence 12	Page No.: 1-18	Meaning: 1-First page ; 18-Last page	1
40029	0x1D	Page address sequence 13	Page No.: 1-18	Meaning: 1-First page ; 18-Last page	1
40030	0x1E	Page address sequence 14	Page No.: 1-18	Meaning: 1-First page ; 18-Last page	1
40031	0x1F	Page address sequence 15	Page No.: 1-18	Meaning: 1-First page ; 18-Last page	1
40032	0x20	Page address sequence 16	Page No.: 1-18	Meaning: 1-First page ; 18-Last page	1
40033	0x21	Page address sequence 17	Page No.: 1-18	Meaning: 1-First page ; 18-Last page	1
40054	0x36	Page address sequence 18	Page No.: 1-18	Meaning: 1-First page ; 18-Last page	1
40034	0x22	Demand Interval Method	Value: 0x0000	Meaning : Sliding	1
			Value: 0x0001	Meaning : Fixed	
40035	0x23	Demand Interval Duration	Min Value : 1	Max Value : 30	1
40036	0x24	Demand Interval Length(min)	Min Value : 1	Max Value : 30	1
40037	0x25	Reset MAX kW	1	Reset MAX Active Power	1
40038	0x26	Reset MIN kW	1	Reset MIN Reactive Power	1
40039	0x27	Reset MAX kVar	1	Reset MAX Reactive Power	1
40040	0x28	Reset MIN kVar	1	Reset MIN Reactive Power	1
40041	0x29	Reset MAX kVA	1	Reset MAX Apparent Power	1
40008	0x08	Baud rate (bps)	Value : 0x0000	Meaning : 300	1
			Value : 0x0001	Meaning : 600	
			Value : 0x0002	Meaning : 1200	
			Value : 0x0003	Meaning : 2400	
			Value : 0x0004	Meaning : 4800	
			Value : 0x0005	Meaning : 9600	
			Value : 0x0006	Meaning : 19200	

## MODBUS REGISTER ADDRESSES LIST

Readable parameters : [ Length (Register) : 2 ; Data Structure : Float ]								
Note : In four byte data type , LSB will be displayed on lower address and MSB will be displayed on higher address.								
Address	Hex Address	Parameter	Address	Hex Address	Parameter	Address	Hex Address	Parameter
30000	0x00	Voltage 1st Phase	30030	0x1E	kVA1	30060	0x3C	Import kWh
30002	0x02	Voltage 2nd Phase	30032	0x20	kVA2	30062	0x3E	Import kWh
30004	0x04	Voltage 3rd Phase	30034	0x22	kVA3	30064	0x40	kW MAX Active Power
30006	0x06	Average Voltage LN	30036	0x24	kVar1	30066	0x42	kW MIN Active Power
30008	0x08	Voltage V12	30038	0x26	kVar2	30068	0x44	kVar MAX Reactive Power
30010	0x0A	Voltage V23	30040	0x28	kVar3	30070	0x46	kVar MIN Reactive Power
30012	0x0C	Voltage V31	30042	0x2A	Total kW	30072	0x48	kVA MAX Apparent Power
30014	0x0E	Average Voltage LL	30044	0x2C	Total kVA	30074	0x4A	Export kWh
30016	0x10	Current I1	30046	0x2E	Total kVar	30076	0x4C	Export kWh
30018	0x12	Current I2	30048	0x30	PF1	30132	0x84	Serial no(Data Structure : Hex)
30020	0x14	Current I3	30050	0x32	PF2	30134	0x86	Existing MAX active power
30022	0x16	Average Current	30052	0x34	PF3	30136	0x88	Existing MIN active power
30024	0x18	kW1	30054	0x36	Average PF	30138	0x8A	Existing MAX reactive power
30026	0x1A	kW2	30056	0x38	Frequency	30140	0x8C	Existing MIN reactive power
30028	0x1C	kW3	30058	0x3A	Import kWh	30142	0x8E	Existing MAX apparent power
Readable Parameters : [Data Structure : Hex]								
NOTE : LSB will be displayed on lower address and MSB will be displayed on higher address.								
Address	Hex Address	Parameter	Length	Address	Hex Address	Parameter	Length	
31000	0x3E8	Volatge V1N	2	31040	0x410	kVar3	2	
31002	0x3EA	Voltage V2N	2	31042	0x412	Total Kw	2	
31004	0x3EC	Voltage V3N	2	31044	0x414	Total Kva	2	
31006	0x3EE	Average Voltage LN	2	31046	0x416	Total Kvar	2	
31008	0x3F0	Voltage V12	2	31048	0x418	PF1	1	
31010	0x3F2	Voltage V23	2	31049	0x419	PF2	1	
31012	0x3F4	Voltage V31	2	31050	0x41A	PF3	1	
31014	0x3F6	Average Voltage LL	2	31051	0x41B	Average PF	1	
31016	0x3F8	Current I1	2	31052	0x41C	Frequency	1	
31018	0x3FA	Current I2	2	31054	0x41E	Import kWh	3	
31020	0x3FC	Current I3	2	31057	0x421	kVAh	3	
31022	0x3FE	Average Currant	2	31060	0x424	Import kVarh	3	
31024	0x400	Kw1	2	31064	0x428	kW Max active power	2	
31026	0x402	Kw2	2	31066	0x42A	kW Min active power	2	
31028	0x404	Kw3	2	31068	0x42C	kVar Max reactive power	2	
31030	0x406	Kva1	2	31070	0x42E	kVar Min reactive power	2	
31032	0x408	Kva2	2	31072	0x430	kVA Max apparent power	2	
31034	0x40A	Kva3	2	31074	0x432	Export kWh	3	
31036	0x40C	Kvar1	2	31077	0x435	Export kVarh	3	
31038	0x40E	Kvar2	2					
Energy Rollover Counter Address : This counter will increment when energy is rollover from 9999999 to 0.								
Address	Hex Address	Parameter	Length	Address	Hex Address	Parameter	Length	
31130	0x46A	IMP Kwh RC*	1	31133	0x46D	EXP Kwh RC*	1	
31131	0x46B	IMP Kvah RC*	1	31134	0x46E	EXP Kvarh RC*	1	
31132	0x46C	IMP Kvarh RC*	1					
NOTE : RC* : Rollover Counter								

## DECLARATION OF CONFORMITY

We, Eaton Electric GmbH., declare under our sole responsibility as the manufacturer that the EMC3P-D2P1 meter described within this manual corresponds to the production model described in the EC-type examination certificate and to the requirements of the 2014/22/EC Directive EC type examination certificate number 0120/SGS0347. The identification number of the notified body is 0120.

## MECHANICAL INSTALLATION / DIMENSIONS (in mm)

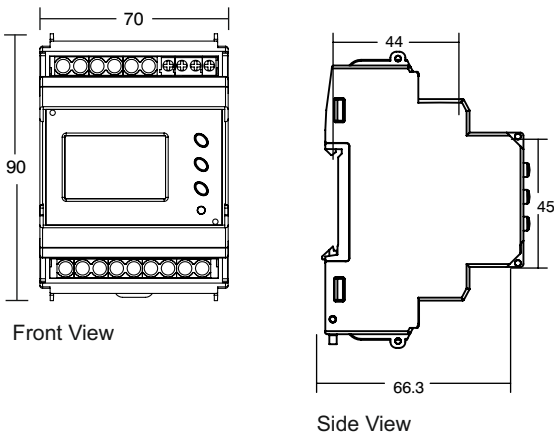

**TYPICAL WIRING DIAGRAM**

**3 Phase-4 Wire (Commonly Used)** 3 Ø - 4 Wire, 3 CT'S

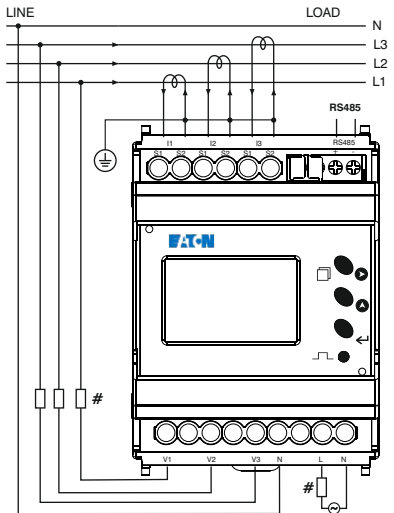

**3 Phase - 3 Wire** 3 Ø - 3 Wire, 2 CT'S

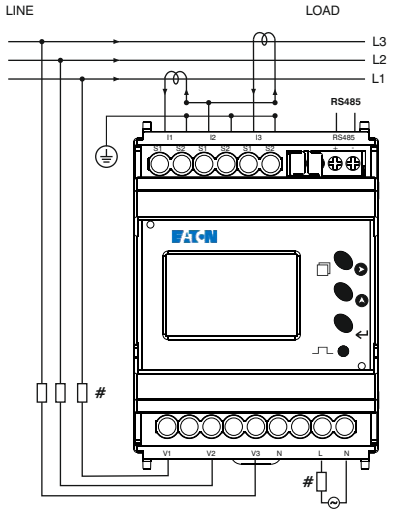

**3 Phase - 4 Wire** 3 Ø - 4 Wire, 3 CT'S and 3 PT'S

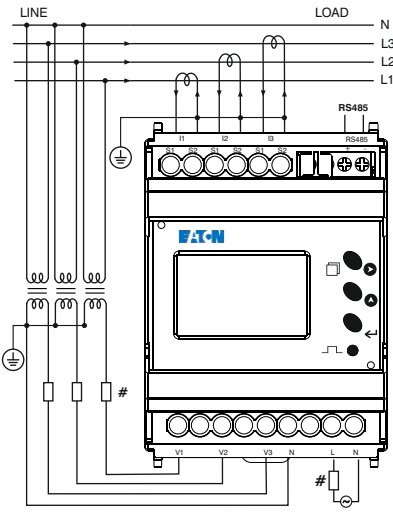

**2 Phase - 3 Wire** 2 Ø - 3 Wire, 2 CT'S and 2 PT'S

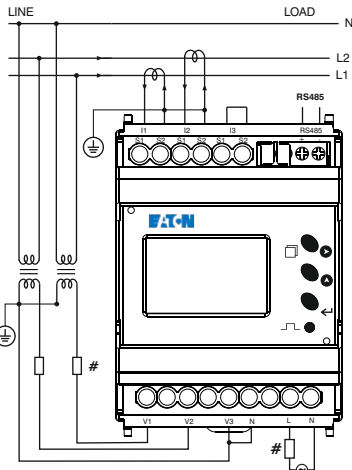

**2 Phase - 3 Wire** 2 Ø - 3 Wire, 2 CT'S

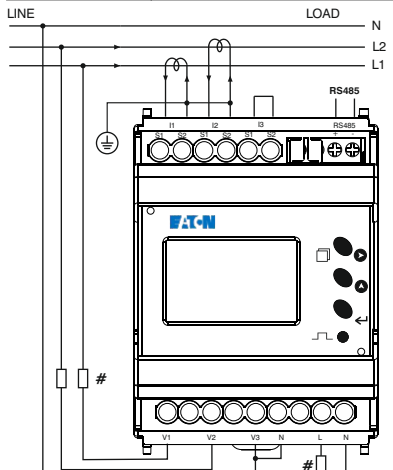

**1 Phase - 2 Wire** 1 Ø - 2 Wire, 1 CT

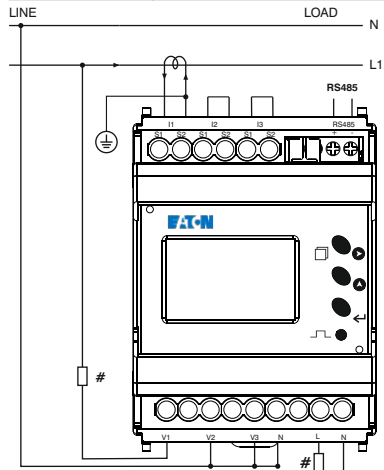

**3 Phase - 3 Wire** 3 Ø - 3 Wire, 2 CT'S and 2 PT'S

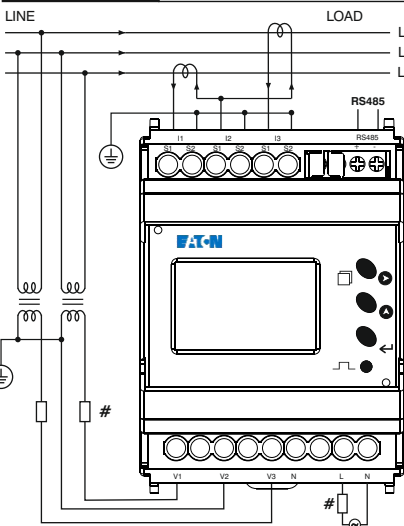

**TERMINAL CONNECTIONS**

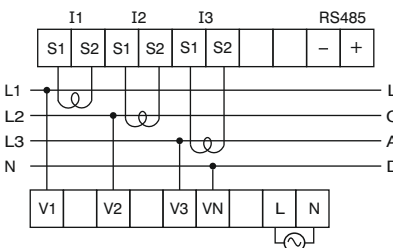

Note: # All fuse types: 0.5A class CC UL type 0.5A fast acting 600V

**CONNECTION DIAGRAM FOR COMMUNICATION**

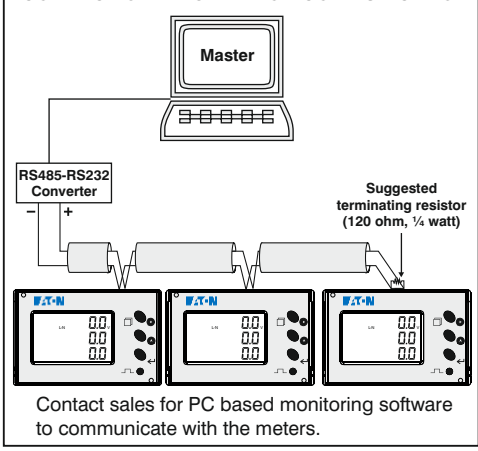

(Specifications subject to change, as development is a continuous process.)

**Eaton Industries (Austria) GmbH,  
Eugenia 1, A-3943, Schrems, Austria  
Website: [www.eaton.com/meter](http://www.eaton.com/meter)  
Support: [techsupportmea@eaton.com](mailto:techsupportmea@eaton.com)**



**[www.eaton.com/recycling](http://www.eaton.com/recycling)**