

Dimensions

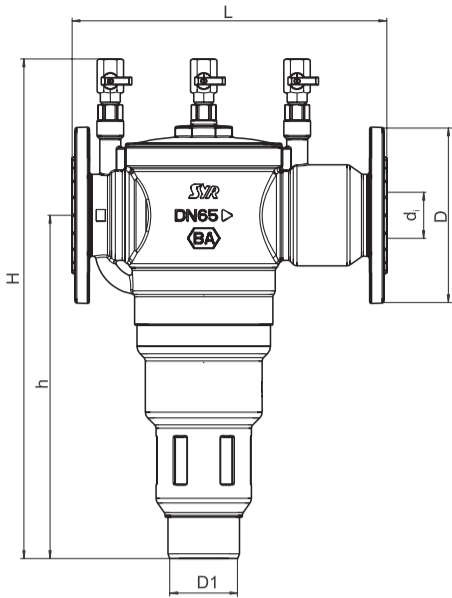

Nominal size		DN 65	DN 80	DN 100
Dimensions in mm	L	330	350	350
	H	496,5	513,5	537,5
	h	365	370	382,5
	d ₁	65	80	100
	D	185	200	220
	D1	75	75	75

WARNING

Only qualified installers are authorized to mount and service the device. Observe the maintenance instructions! The warranty does not cover malfunctions caused by dirt.

Spare parts

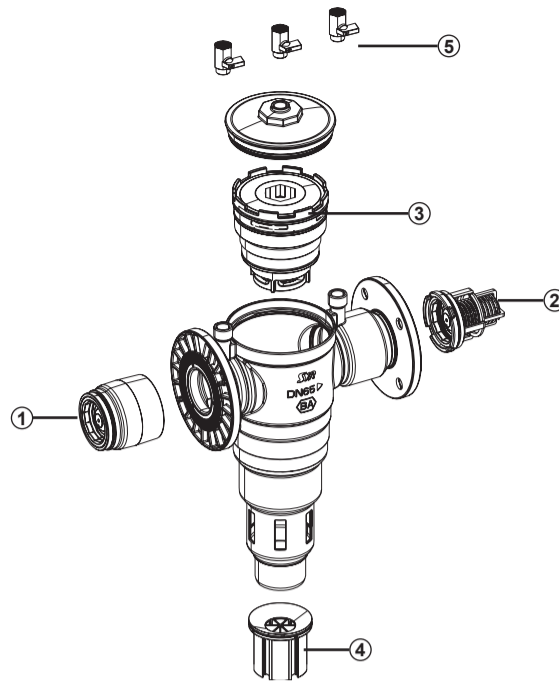

- ① **Check valve cartridge inlet**
DN 65: 29 9891
DN 80: 29 9892
DN 100: 29 9893
- ② **Check valve cartridge outlet:**
DN 65: 29 9894
DN 80: 29 9895
DN 100: 29 9896
- ③ **Control unit:** 29 9897
 ④ **Tundish:** 29 9898
- No pict.**
Assembly tools 29 9890

SYR[®] ARMATUREN

Made in Germany

Instructions for use and installation

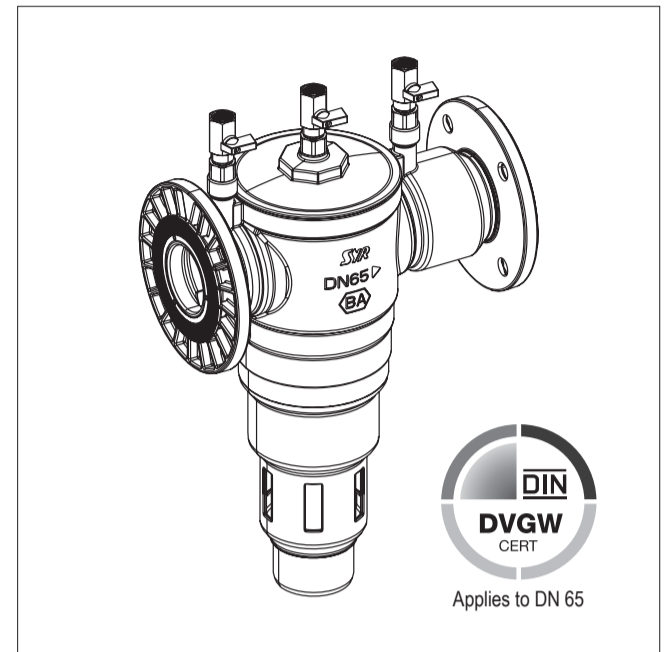

Flanged Backflow Preventer BA 6600 DN 65 - 100

Field of application

The Backflow Preventer BA 6600 is designed to protect potable water against non-potable water up to and including fluid category 4 according to EN 1717. The BA Backflow Preventer covers many applications such as printing, chemical and food industry or laboratory and medical technology.

Design

The BA Backflow Preventer includes the following parts: Body, integrated strainer, BA Backflow Preventer according to EN 1717 up to and including fluid category 4, 3 ball valves for the connection of a differential pressure manometer and tundish.

Materials

Body made of gunmetal, Backflow Preventer made of high-quality synthetic material and gunmetal, ball valves made of brass, sealing elements in conformity with the regulations of the German Public Health Office (KTW).

Technical specifications

Fluid:	potable water
Upstream pressure:	max. 10 bar
Min. inlet pressure:	1.5 bar
Mounting position:	horizontal, tundish pointing downwards
Service temperature:	max. 65 °C
Drain pipe connection:	DN 65
Flow rate:	DN 65: 80 m ³ /h, Δp 1.5 bar DN 80: 110 m ³ /h, Δp 1.5 bar DN 100: 125 m ³ /h, Δp 1.5 bar

Function

The BA Backflow Preventer (Reduced Pressure Zone Valve) from SYR includes all components set by EN 1717 and is designed as 3 pressure-zone-system with a controllable upstream, intermediate and downstream pressure zone. Each pressure zone is equipped with ball valves that make it possible to check each zone and to ensure the leak-tightness of the safety devices by pressure measurement. The BA Backflow Preventer is equipped with 2 consecutive check valves with an intermediate pressure zone in between, which can be vented to the atmosphere. When no water is drawn, the check valves on either side and the drain valve are closed. In case of back-siphonage, the inlet pressure drops. The drain valve opens at the latest, when the differential pressure between the upstream and intermediate zone decreases to 0.14 bar.

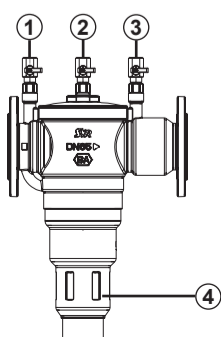

- ① **Upstream pressure zone**
 ② **Intermediate pressure zone**
 ③ **Downstream pressure zone**
 ④ **Tundish**

Installation

Thoroughly flush the pipe prior to installation. Service valves shall be provided either side of the Backflow Preventer. Mount the device in the pipe with the tundish pointing downwards to ensure perfect operation. Free access to the Backflow Preventer shall be provided to facilitate maintenance works and inspections. Do not install the device in locations liable to frost and flooding. It should only be mounted in a well-ventilated environment. The drain pipe's diameter shall be able to accommodate the maximum discharge volume. We recommend to install a potable water filter according to EN 13443, part 1 upstream of the Backflow Preventer in order to ensure perfect functionality. Once installed, vent the device by means of the 3 ball valves. Then, the Backflow Preventer is ready for operation. When connecting the tundish to the sewer, comply with the requirements set in the standard EN 12056.

How to replace the Backflow Preventer cartridge

Depressurize the device prior to opening!

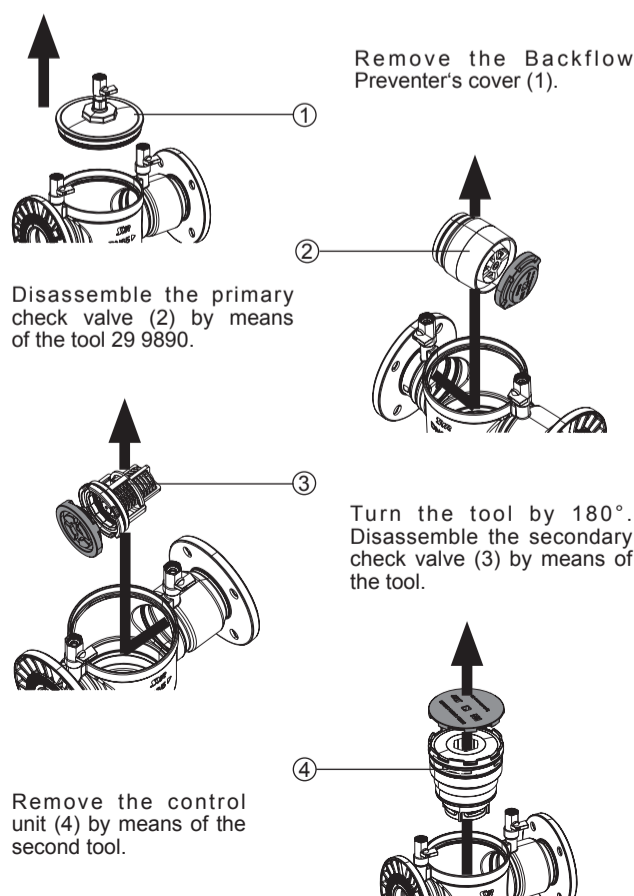

It is compulsory to service the BA Backflow Preventer on a regular basis. Therefore, maintenance agreements between user and installer are very useful. The correct function of the Backflow Preventer has to be verified after the first service year, then periodically according to the operating conditions, but every year at the latest. Use the pressure measurement device (accessories; differential pressure kit art. nr. 29 9985) to check the correct operation of the device with the ball valves in each pressure zone. The device is easy to service as the Backflow Preventer is designed with a cartridge.

How to check the disconnecting function of the discharge valve and the secondary check valve

- When checking the discharge valve, close both shut-off valves 4a + 4b.
- Remove the manometer plugs on the service valves 1+2.
- Open the service ball valves 1 + 2 to depressurize the device.
- Mount the measuring device's needle valves on the service ball valves 1+2.
- Fit the measuring device.
- Open both shut-off valves 4a + 4b.
- Vent the device by means of both needle valves. Close them again.
- Close the shut-off valves 4a + 4b.
- Relieve the pressure slowly by means of the needle valve 1.
- Watch the tundish. When the first drop comes out of the tundish, the diff. pressure shall exceed 140 mbar. If it is not case, dirt has accumulated in the device or there is a mechanical defect.
- Open the needle valve 1 and discharge the intermediate pressure zone until completely drained.
- To verify the secondary check valve, open the shut-off valve on the outlet side (4b). Should water drip from the tundish, there is probably a mechanical defect or dirt has accumulated in the secondary check valve.
- Close both service ball valves 1+2.
- Remove the measuring device and put the manometer plugs back in their position (service ball valves).
- Open both shut-off valves (4a + 4b).

