

INSTRUCTION MANUAL

MULTICONTROL MODULAR

EMCM-_2 ... _9 (-TWIN)



Copyright ©

All rights reserved. No part of this user manual may be reproduced and/or published on the Internet, by means of printing, photocopying, microfilm or in any other way without the prior written permission of Spirotech bv.

TABLE OF CONTENTS

1.	PREFACE	5
	1.1. About the device.....	5
	1.2. About this document.....	5
	1.3. Symbols.....	5
2.	SAFETY	6
	2.1. Safety instructions.....	6
3.	GENERAL.....	9
	3.1. Description of the device.....	9
	3.2. CE mark.....	9
4.	ASSEMBLY	10
	4.1. Setting up the device	10
	4.2. Degassing module EMAE and backfeed module EMCF	11
	4.3. Connection to the water supply system.....	11
	4.4. Connection side right / left	12
	4.5. Use of cooling vessels.....	12
	4.6. Temperature sensor T2	13
	4.7. Electrical connection	14
5.	HYDRAULIC CONNECTION DIAGRAMS	15
	5.1. MultiControl Modular with degassing function	15
	5.2. MultiControl Modular without degassing function (standard scheme).....	16
	5.3. MultiControl Modular without degassing function with cooling vessel	17
6.	CIRCUIT DIAGRAMS	18
	6.1. MultiControl Modular EMCM-_2 ... _9	18
	6.2. MultiControl Modular EMCM-_2 ... _9 (2 mains supply cables)	19
	6.3. MultiControl Modular EMCM-_2 ... _9	20
	6.4. MultiControl Modular EMCM-_2 ... _9	21
	6.5. MultiControl Modular EMCM-_2 ... _9	22
	6.6. MultiControl Modular EMCM-_2 ... _9	23
7.	COMMISSIONING	24
	7.1. Putting the device into operation	24
8.	CLEANING AND MAINTENANCE.....	31
	8.1. Cleaning.....	31
	8.2. Maintenance	31

9.	SPARE PARTS LIST.....	32
9.1.	Piping	32
9.2.	Elektronik	34
9.3.	EMCF backfeed module.....	36
9.4.	Degassing module EMAE.....	37
9.5.	Power section	38
10.	CERTIFICATES	39
10.1.	CE declarations of conformity	39
11.	APPENDIX	40
11.1.	Sizing the expansion line	40
11.2.	Details on connecting EMCM with EP-R(S).....	41

Disclaimer of Liability

This instruction manual has been prepared with the greatest care possible. However, we are constantly striving to improve our products and we reserve the right to make changes at any time and without prior notice. We do not guarantee the accuracy and completeness of this document. Any claims, in particular claims for damages and loss of profit or financial loss, are excluded.

1. PREFACE

1.1. About the device

These operating instructions cover the installation, commissioning and operation of the following MULTICONTROL types:

TYPE	DESCRIPTION	COMPOSITION
EMCM-S2 ... S9-__	MultiControl Modular SOLO	Single pump 100%, single valve 100%
EMCM-D2 ... D9-__	MultiControl Modular DUO	Double pump 2x50%, single valve 1x100%
EMCM-D2 ... D9-__-TWIN	MultiControl Modular DUO TWIN	Double pump 2x50%, single valve 2x100%
EMCM-M2 ... M9-__	MultiControl Modular MAXI	Double pump 2x100%, single valve 1x100%
EMCM-M2 ... M9-__-TWIN	MultiControl Modular MAXI TWIN	Double pump 2x100%, single valve 2x100%

1.2. About this document





Read this instruction manual before installation, commissioning and operation. Keep the instructions for future reference.

The original language of the document is German. All other available language versions are translations of the original instructions.

The illustrations in this document show a typical structure with relevant details and may differ from the model supplied depending on the type and equipment, but do not affect the comprehensibility of this document.

1.3. Symbols

The following symbols are used in these operating instructions:

SYMBOLS		
	CAUTION	This symbol warns of a dangerous situation in which failure to observe the hazard warning may result in minor, reversible injuries.
	WARNING	This symbol warns of an extremely dangerous situation in which failure to observe the hazard warning may result in death or serious irreversible injury.
	ELECTRICAL HAZARD	This symbol warns of the risk of electric shock.
	NOTE	This symbol warns of situations in which failure to observe the instructions can lead to material damage.

2. SAFETY

2.1. Safety instructions

This safety information warns the user of risks and shows how the risks can be avoided.

Due to the design of the pressurisation unit, hardly any hazards are to be expected.

However, it should always be noted that hot system media (e.g. heating water) or even harmful media can leak out when handling these devices!

Since different devices each may have a special medium contained within, EDER Spirotech cannot predict which medium the respective system will use. This also applies to harmful mixtures of media that may be used in the system.

It is the responsibility of the installer of the system and, after proper handover, the responsibility of the operator of the system to take appropriate safety-related measures if necessary.

Take precautions and, if necessary, attach warning signs to the device!



WARNING

The following areas of application are expressly excluded:

- Use in potentially explosive atmospheres
- Use outdoors
- Use in rooms with risk of water jets
- Use in areas with heavily polluted ambient air

If it is the case that the system medium is a hazardous, harmful substance, the following hazardous situations may arise:

A filling and emptying tap is located on the lower flange of the EP-R(S) expansion vessel(s) on MultiControl Modular appliances. This is used for maintenance purposes, where hot system media can escape when the tap is opened.



WARNING

In this case there is a risk of scalding!

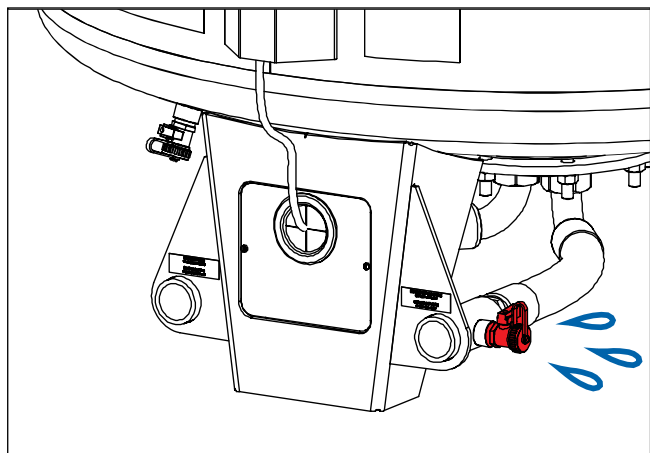

Figure 1: Filling and emptying tap of the vessel

There is a 0.5 bar safety valve on the top flange of the EP-R(S) expansion tank, which can be triggered by the following causes and thus allow hot and harmful system media to escape:

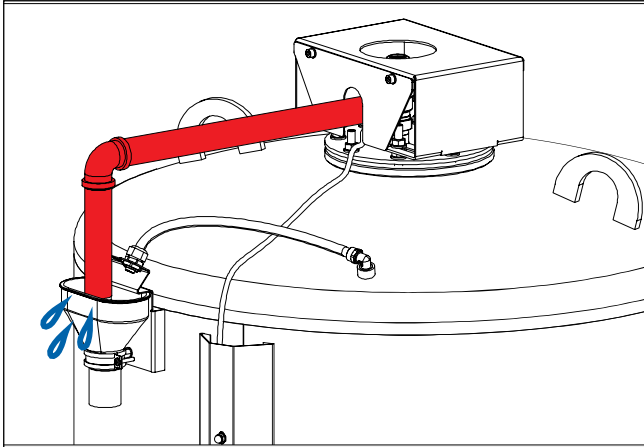

Figure 2: Safety valve of the container

- The expansion valve and the expansion tank have been sized incorrectly (too small) and the entire expansion volume cannot be accommodated in the tank.
- The content measurement may not work correctly due to defective pressure transmitters or a defective membrane, which can cause the container to overflow.
- The tank was filled to too high a level when cold (possibly by the "Fill once" function or uncontrolled if the EMCF backfeed module is not installed), whereby the expansion volume that occurs was not taken into account and can therefore no longer be fully absorbed in the tank.



WARNING

In this case there is a risk of scalding!

There is an emptying tap at the bottom of the EP-R(S) expansion tank, which is not expected to pose any danger during normal operation. If the membrane installed in the tank is defective for any reason, hot and harmful system media can leak out through this tap.



WARNING

In this case there is a risk of scalding!

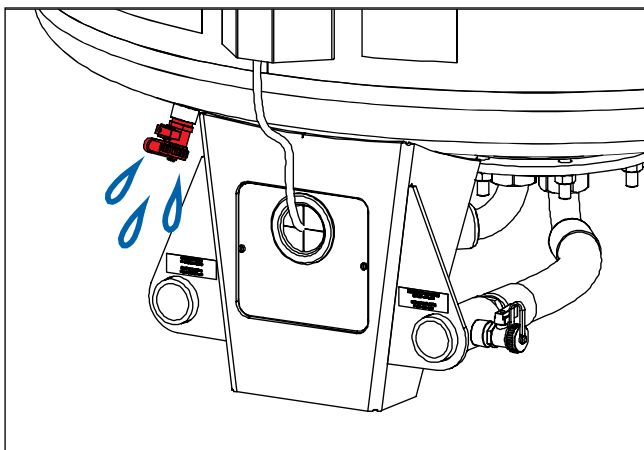

Figure 3: Emptying tap of the vessel

**WARNING**

Installation, commissioning and servicing may only be carried out by trained specialist personnel.

If the device is damaged, it must be taken out of operation and repaired by trained specialists.

The device must be de-energised before carrying out any electrical work!

No changes may be made to the product.

Operation is only permitted with the housing closed.

**NOTE**

Illustrations in this document may differ from the model supplied depending on the type and equipment.

**CAUTION**

Spirotech devices are subjected to a functional test at the factory before delivery and the device is filled with a frost-protected ready-mixed test water. Although the device is emptied as far as possible after the function test, small quantities of testing water (max. approx. 1.5 litres) may remain in the device, depending on the device type and design.

This test water is frost-protected down to -20°C and is produced on the basis of propylene glycol together with protective substances. Experience has shown that such small quantities of test water in the system do not cause any problems at the final destination when mixed with the system water there.

However, if there are concerns about the introduction of such a small amount of test water into the system at the destination, the pressurisation unit must also be flushed before connecting it to the system in the same way as is specified for the system itself (e.g. in ÖNORMH5195-1)

3. GENERAL

3.1. Description of the device

MultiControl Modular EMCM for loss-free absorption of the expansion volume and for pressure stabilisation in closed heating, air-conditioning and cooling systems. Manufactured in accordance with the EN 12828 construction guidelines.

Attractive, self-contained unit in a self-supporting, sound-insulating construction for MODULAR combination with unpressurized expansion tanks (max. 0.5 bar), connections for suction and overflow lines on the back.

Control unit as a COMPACT hydraulic with one or two low-noise pressure maintenance pump(s) (model SOLO 1x100%, model DUO 2x50%, model MAXI 2x100%) in the version as a vertical, normally suction high centrifugal pump in inline design with a highly wear-resistant cartridge mechanical seal made of the highest quality material pairing (but can still be easily changed from the outside if necessary), one (model SOLO, DUO and MAXI) or two (models DUO TWIN and MAXI TWIN) pressure-proportionally continuously regulating, mechanically adjusted overflow valve(s) (1x100% or 2x100% of the expansion volume flow). Precision system pressure measurement. Hydraulic connection (expansion line) for on-site integration ex works on the left and with necessary shutoff (can be easily converted to the right). Temperature monitoring of the system medium entering the tank.

Prepared connection point for easy assembly of the backfeed module for quantity-controlled, litre-precise backfeed, also available for retrofitting at any time. Water treatment can be combined with the backfeed module (softening, demineralisation) for standard-compliant backfeed water.

Furthermore, prepared connection point for easy installation of a degassing module for automatic, economical low-pressure degassing function based on the principle of depressurisation, also available for retrofitting at any time. Connection for degassing line then at the rear including necessary shutoff.

Electronic control unit in microprocessor design for controlling all processes, ergonomically arranged control panel with sophisticated operating concept in many national languages. Self-contained compact measuring and switching unit in closed switch cabinet design including connection cables and load circuit for pump switching with motor protection switch and main switch in separate switch box. The basic version already includes four potential-free signalling contacts (fault, warning, backfeed running, device function enabled) as well as inputs for "ext. Enable contact device function" and "external message".

For extended signal exchange, prepared installation slots for additional expansion modules (also for retrofitting). Remote monitoring of the device is also possible using various MULTICONTROL bus modules or MULTICONTROL web module (also prepared for retrofitting). Additional external temperature monitoring provided by optional temperature sensor at the point of integration into the system.

- max. safety temperature of the system: 110 °C (with cooling vessel)
- max. temperature at the connection point: 70°C

3.2. CE mark

The device is CE labelled. This means that the device has been developed, built and tested in accordance with the applicable health and safety regulations. Provided that the operating instructions are followed, the device can be used and maintained safely.

4. ASSEMBLY

4.1. Setting up the device

The device must be set up on a level, solid floor. Any unevenness must be levelled out. Setting the device up outdoors is not permitted. For devices with adjustable feet, it is also important to ensure that they are set up vertically.

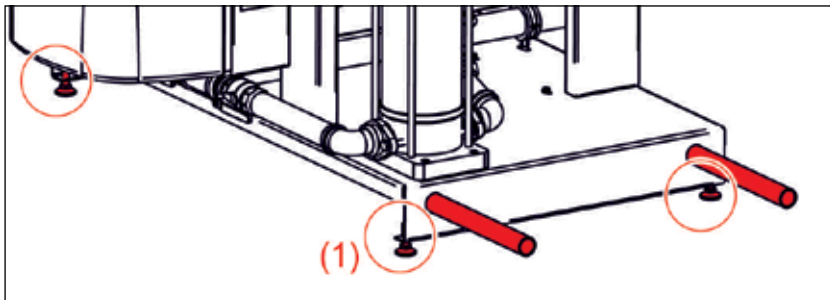

Figure 4: Adjustable feet and transport tubes

The connection of all hydraulic lines from the EMCM to the expansion tanks and to the system must be as stress-free as possible. The nozzle loads introduced into the device through connected piping must not impair the device in any operating phase. Piping must be designed and installed in such a way that impermissible forces are avoided (e.g: by installing expansion joints or setting fixed points immediately before the transition to the connection points on the device).

Storage:

Ambient temperature min./max: -18°C/40°C

Storage area must be protected from precipitation and direct sunlight.

Operation:

The device should only be installed in enclosed indoor areas of buildings. The ambient temperature in the installation room must be between +5°C and +40°C from the time the device is first filled with the system medium until it is taken out of service.

Sufficiently bright electrical lighting must be provided for the display and safety equipment, the operating devices and the access routes. Objects that are not intended for the operation or maintenance of the pressurisation system must not be stored in the immediate vicinity of the system (observe construction and safety regulations).

Integration into the system return is carried out according to the diagrams (in Chapter 5 - "Hydraulic connection diagrams").

Our pressurisation devices are suitable for systems where the maximum temperature at the connection point does not exceed 70 °C. If temperatures of more than 70 °C may occur at the point of integration into the system, a cooling vessel must be used (see chapter 5.5 "Use of cooling vessels"). The connection to the system return must be made at a point where there are no external hydraulic pressures that could influence the proper functioning of the pressurisation system.

The expansion line is sized in accordance with ÖNORM H5151-1. See Appendix 12.1.

i NOTE

We recommend connecting the pressurisation unit with a minimum dimension of DN25.

For details on the hydraulic connection of MULTICONTROL MODULAR with EP-R(S) expansion vessels, see the appendix.

! CAUTION

Danger of damage due to stray welding currents during installation with electric welding processes! If the welding current return cable is connected incorrectly to the part of the system to be welded, welding current may flow via the protective earth conductor. This can destroy protective conductors, damage devices and electrical equipment, overheat components and cause fires!

4.2. Degassing module EMAE and backfeed module EMCF

Devices in the MULTICONTROL MODULAR series are supplied ex works without EMAE degassing module or EMCF backfeed module. Retrofitting is possible at any time. These modules are installed in accordance with the instructions supplied with the respective module.

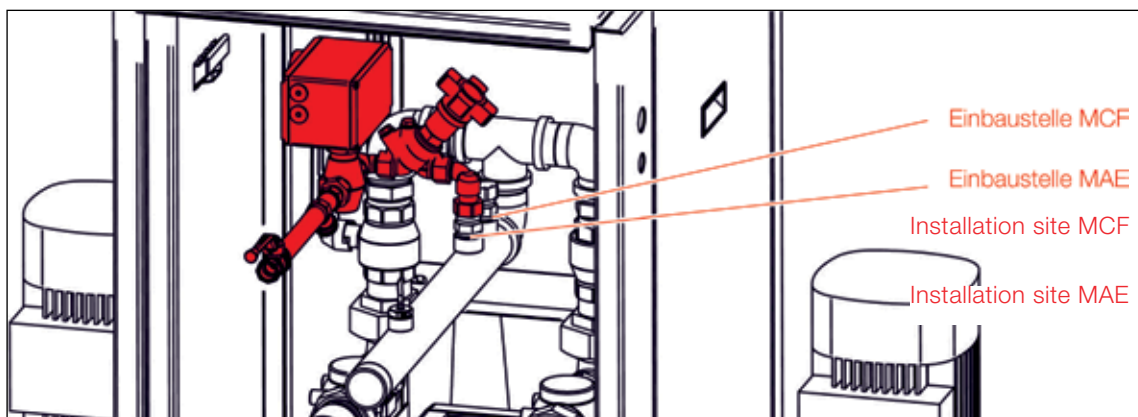

Figure 5: MAE degassing module / EMCF backfeed module

4.3. Connection to the water supply system

Devices with a built-in backfeed module (EMCF) are equipped with a connection for fresh water supply.

If the fresh water connection is connected to the public water supply system, non-drinking water (heating water) must be prevented from being siphoned back into the water supply system. Appropriate devices that reliably prevent back siphoning are not built into the MULTICONTROL device and must be provided externally (on site) (e.g. system separator).

FRESH WATER CONNECTION:

Highest inlet water pressure: 1.0 MPa = 10 bar

Lowest inlet water pressure: 0.2 MPa = 2 bar

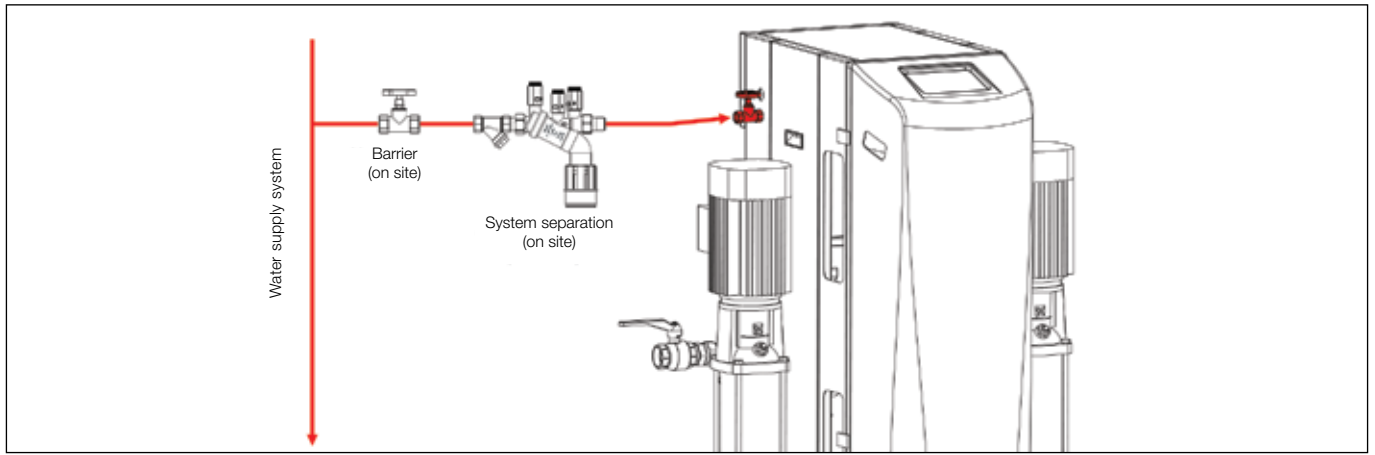

Figure 6: Connection for fresh water supply



WARNING

Devices intended for connection to the water supply system must be fitted on site with devices that reliably prevent non-drinking water from being siphoned back into the water supply system.

4.4. Connection side right / left

On devices in the MULTICONTROL EMCM- _2 ... _9 (-TWIN) series, the connections from/to the system return are located on the left-hand side ex works. These can be converted to the right-hand side if required (fig. 7).

4.5. Use of cooling vessels

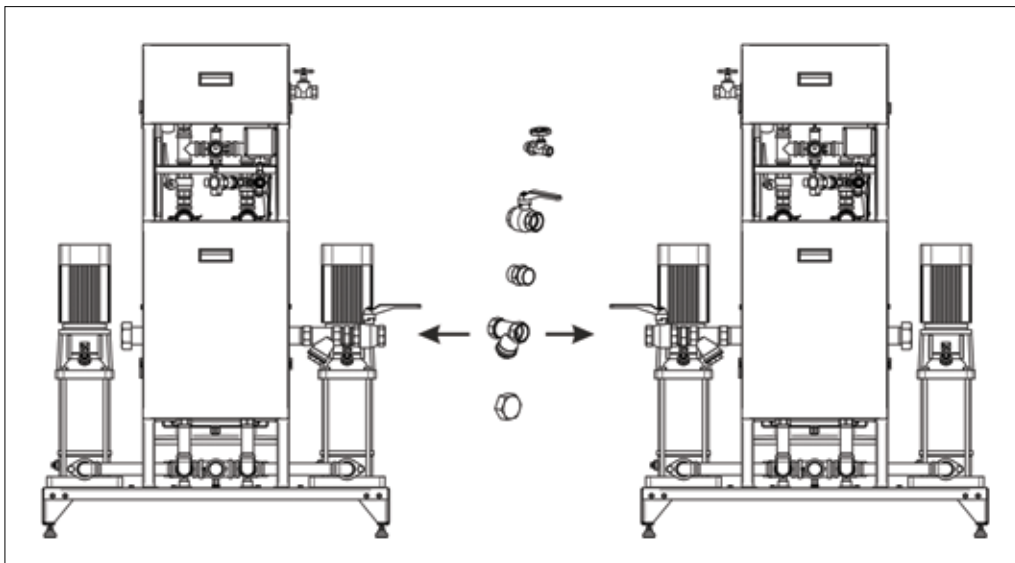

Figure 7: Conversion of connection side hydraulics MULTICONTROL MODULAR

Devices in the MULTICONTROL MODULAR series are suitable for systems where the maximum temperature at the connection point does not exceed 70 °C.

If temperatures of more than 70 °C can occur at the point of integration into the system, a cooling vessel must be used.

Depending on the pipe routing from the system return to the EV cooling vessel, a vent valve must be installed on the upper connection. This must be vented once during commissioning.

i NOTE

When using an EV cooling vessel, ensure that it is not thermally insulated under any circumstances. This also applies to the entire expansion line from the system return to the automatic expansion valve.

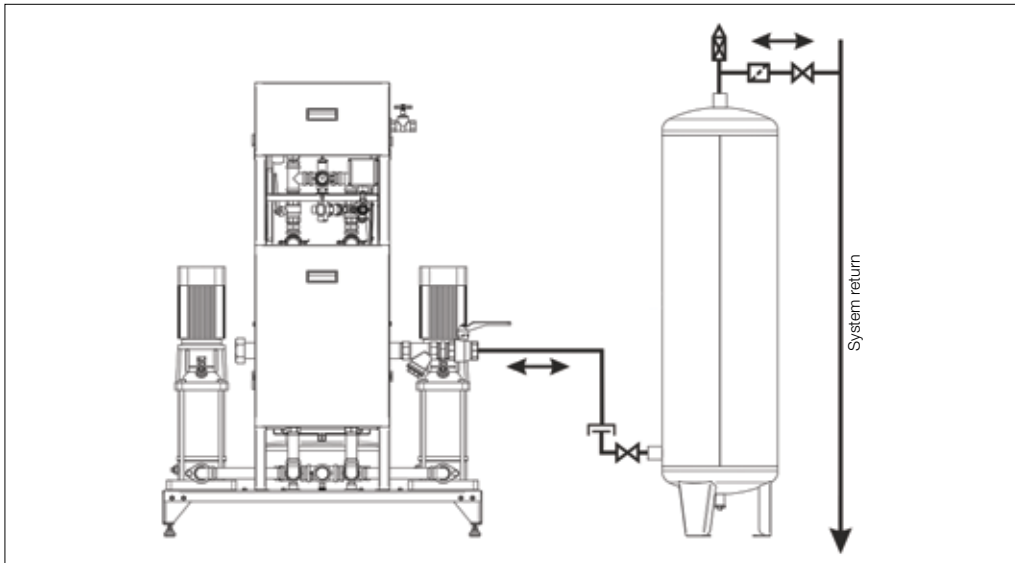

Figure 8: Use of an EV cooling vessel

4.6. Temperature sensor T2

Devices from the MULTICONTROL MODULAR series, in conjunction with the T2 temperature sensor available as an accessory, offer the option of monitoring the temperature in the system return or in the expansion overflow pipe.

This monitoring function is used to protect the device by blocking the degassing function if the temperature is currently too high, so that the fittings and the diaphragm are not damaged during the degassing process by system medium that is too hot or has not yet cooled down. The installation of a T2 temperature sensor is highly recommended for systems with a protection temperature of more than 95 °C.

This temperature sensor is integrated on site in the system return immediately upstream of the connection point (Fig. 9). When using a cooling vessel, a sleeve is provided on the cooling vessel for this purpose (Fig. 10).

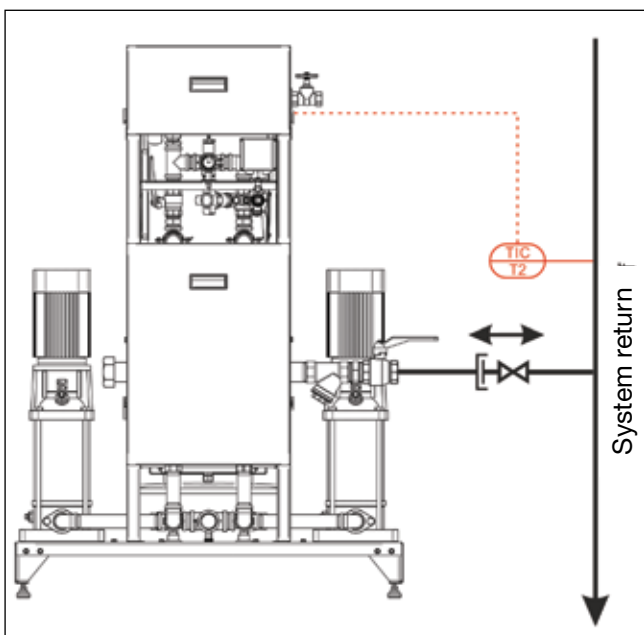

Figure 9: Integration of temperature sensor T2 without cooling vessel

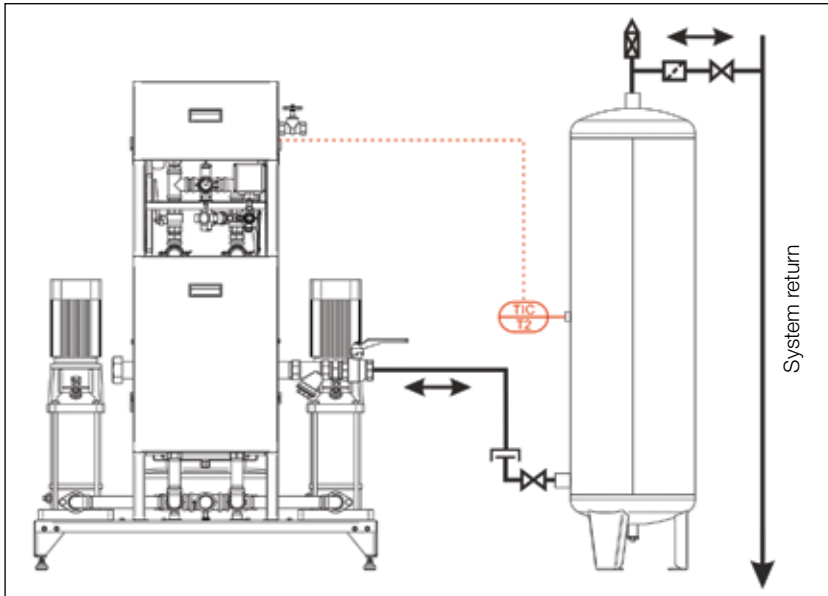

Figure 10: Integration of temperature sensor T2 with cooling vessel

4.7. Electrical connection

EMCM-_2 ..._9 (-TWIN) units are multiphase devices that are equipped with a flexible mains connection cable and are intended for permanent connection to a permanently installed mains connection. The mains connection cable must be attached to the device according to connection type Y.

The device must be secured on site and connected to an external all-pole mains switch.

Ensure that the electrical data specified on the rating plate matches the existing power supply.

The device must be connected to the equipotential bonding before commissioning. A corresponding connection point is provided on the device and labelled accordingly.

CAUTION

If the mains connection cable of this device is damaged, it must be replaced by the manufacturer or its customer service or a similarly qualified person in order to avoid hazards.

WARNING

The applicable electrical regulations must be observed and complied with!

NOTE

The electrical connection values can be found on the type plate of the device.

5. HYDRAULIC CONNECTION DIAGRAMS

5.1. MultiControl Modular with degassing function

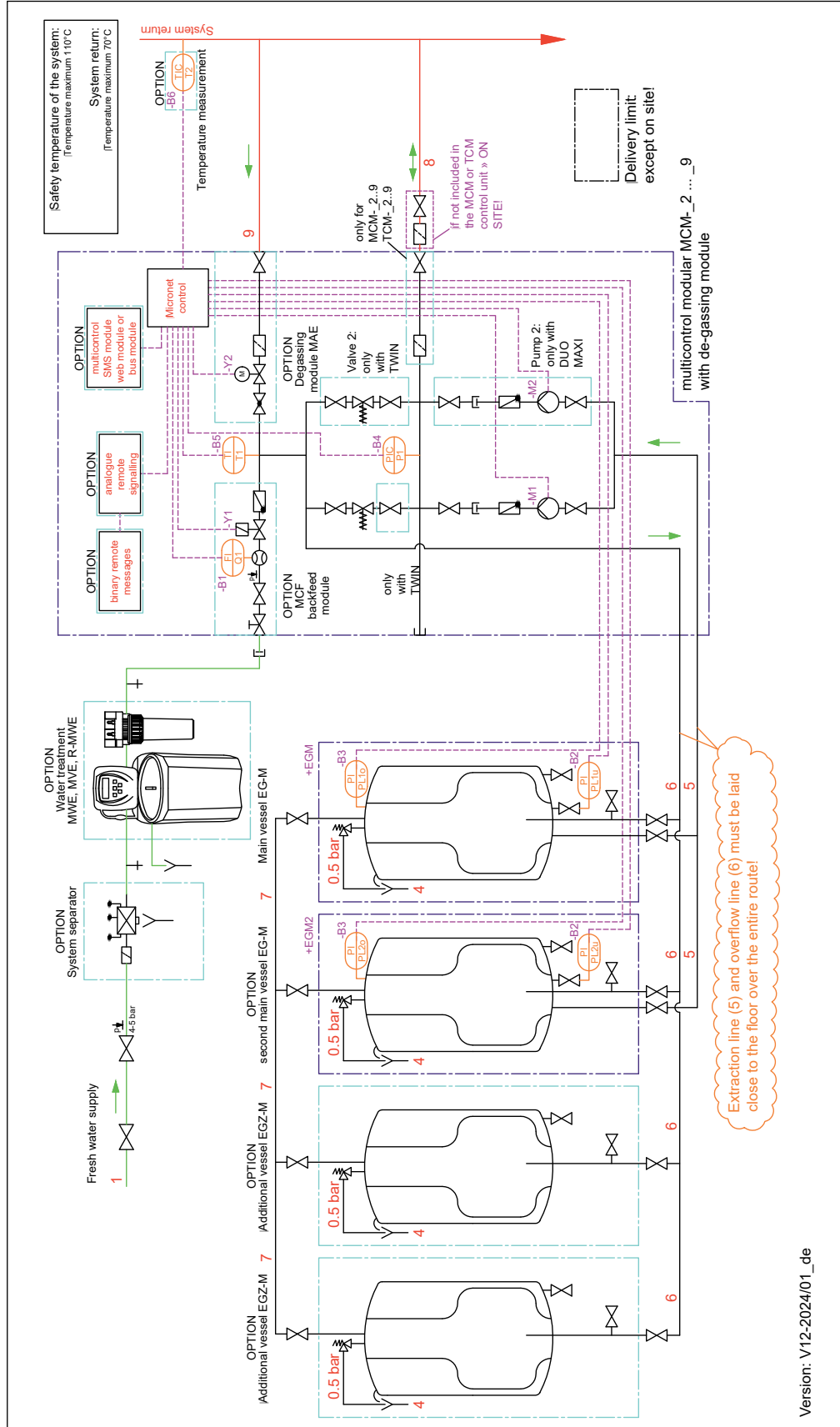

1. Fresh water supply	7. DN20 gas-side vessel connection
4. Vessel safety valve drain pipe	8. Expansion line from/to the system return
5. Suction line from the expansion tank	9. Degassing line from the system return
6. Overflow line to the expansion tank	

Options: EGZ-M additional vessels, expansion modules, EMAE degassing module, EMCF backfeed module, water softener, system separator, sensor T2

5.2. MultiControl Modular without degassing function (standard scheme)

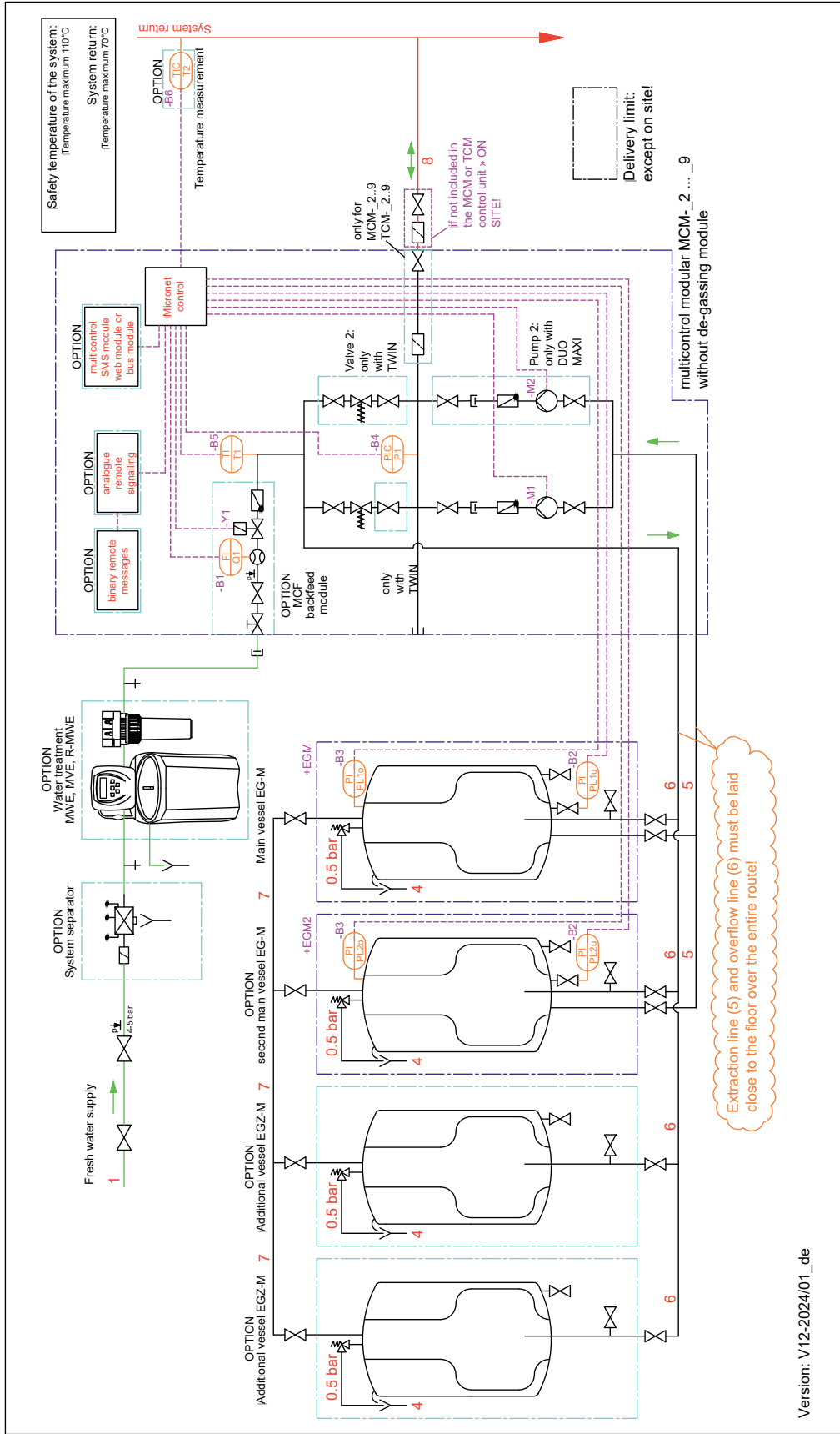

1. Fresh water supply	
4. Vessel safety valve drain pipe	
5. Suction line from the expansion tank	
6. Overflow line to the expansion tank	
7. DN20 gas-side vessel connection	
8. Expansion line from/to the system return	

Options:

EGZ-M additional vessels, expansion modules, EMCF backfeed module, water treatment, system separator, sensor T2

6.2. MultiControl Modular EMCM- 2 ... _9 (2 mains supply cables)

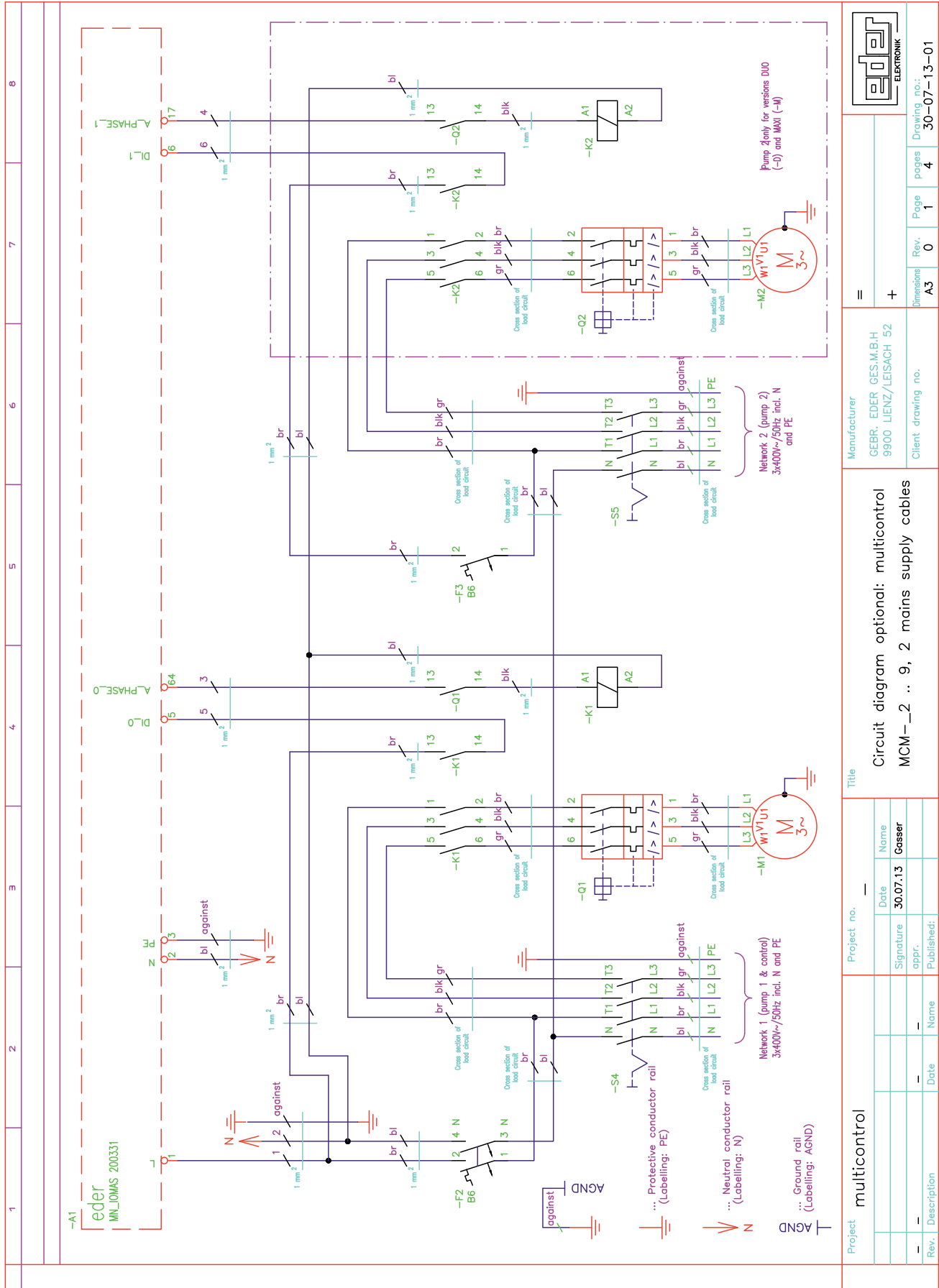

6.3. MultiControl Modular EMCM-2 ... _9

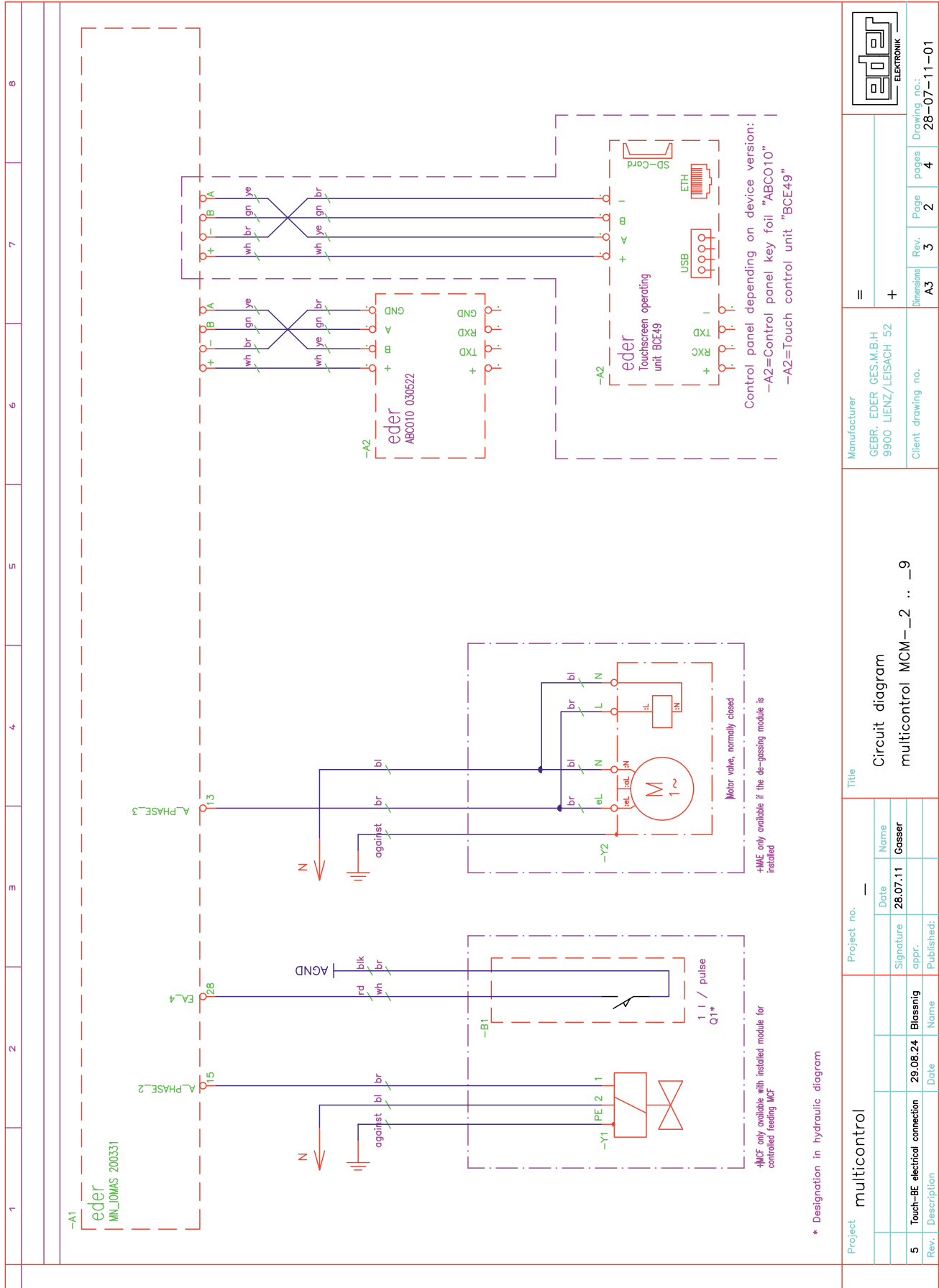

6.4. MultiControl Modular EMCM- 2 ... _9

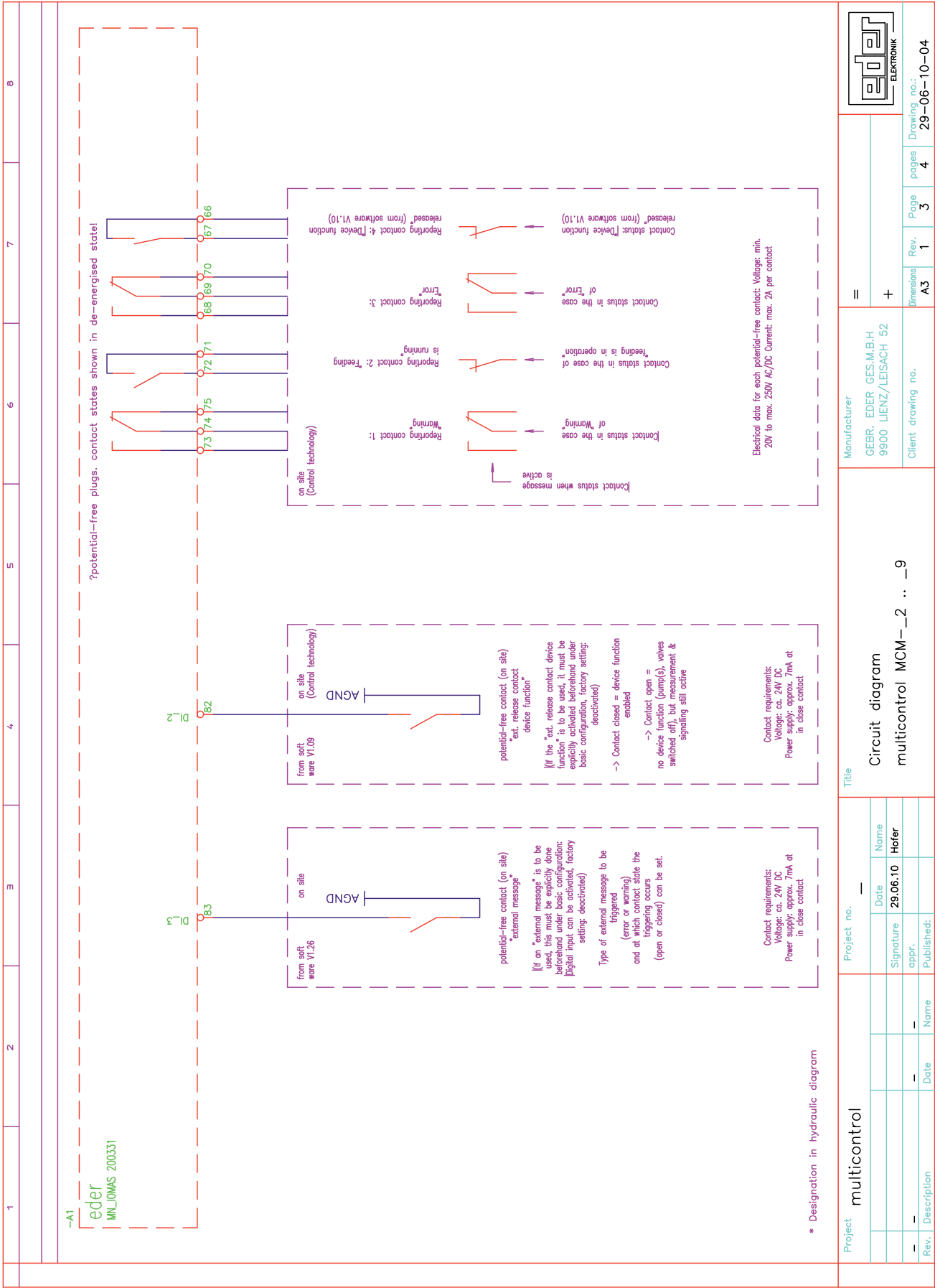

* Designation in hydraulic diagram

6.5. MultiControl Modular EMCM- 2 ... _9

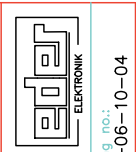
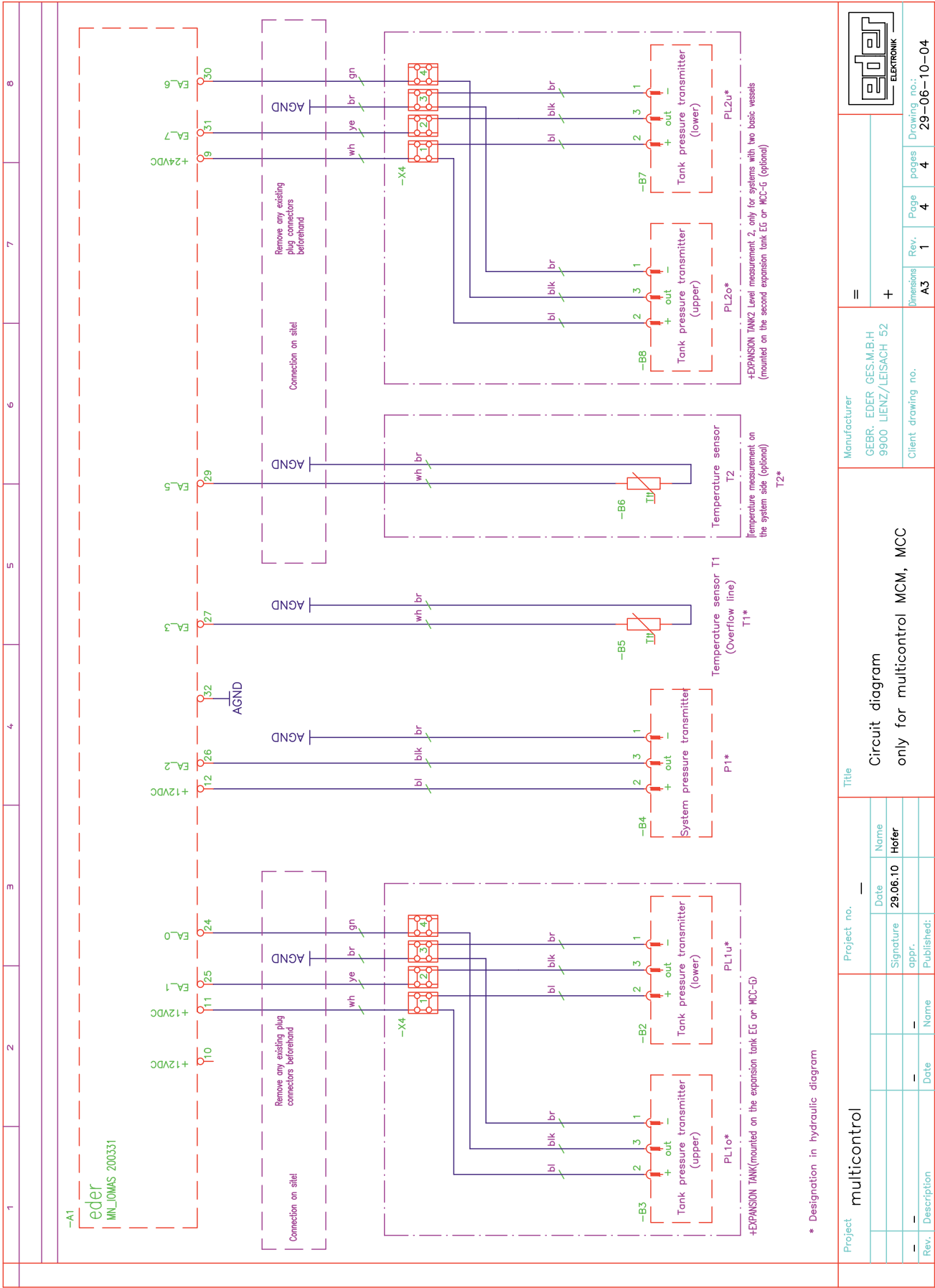

Manufacturer	GEBR. EDER GES.M.B.H 9900 LENZ/LEISACH 52
Client drawing no.	A3
Dimensions	Rev. 1
Page	4
Pages	4
Drawing no.:	29-06-10-04

Title	
Circuit diagram only for multicontrol MCM, MCC	

Project no.	-	
Date	29.06.10	
Name	Hofer	
Signature	[Signature]	
app.	-	
Published:	Date	Name

Project	multicontrol	
Rev.	Description	Date
-	-	-

6.6. MultiControl Modular EMCM- _2 ... _9

DESIGNATION	DESCRIPTION
-A1	Control electronics: MultiControl motherboard, type 200331
-A2	Depending on the device version: Control electronics: Processor board MultiControl, type ABCO10 Control electronics: Touchscreen operating unit, type BCE49
-Y1	EMCF backfeed module: Solenoid valve (option)
-B1	EMCF backfeed module: Water meter pulse output (option)
-B2	Vessel pressure transmitter bottom (PL1u*)
-B3	Vessel pressure transmitter top (PL1o*)
-B4	System pressure transmitter (P1*)
-B5	Temperature sensor (T1*), sensor element KTY10-6 or compatible
-B6	Temperature sensor (T2*), sensor element KTY10-6 or compatible
-B7	Vessel pressure transmitter bottom (PL2u*) (option)
-B8	Vessel pressure transmitter top (PL2o*) (option)
-X4	Connection clamp
-S4	Main switch
-S5	Main switch for mains 2 (only for versions with 2 mains supply cables)
-F2	Automatic circuit breaker, characteristic curve B, 6A, 1-pole + N
-F3	Automatic circuit breaker, characteristic curve B, 6A, 1-pole
-Q1	Motor protection switch for pump 1
-Q2	Motor protection switch for pump 2 (option)
-M1	Motor pump 1
-K1	Protection - Pump motor 1
-M2	Motor pump 2 (option)
-K2	Protection - pump motor 2 (option)
-Y2	Degassing module EMAE: Degassing valve (option)

* Designation in hydraulic diagram

7. COMMISSIONING

7.1. Putting the device into operation

⚠ CAUTION

Commissioning of the device by the Spirotech factory customer service or an authorised partner, including training of the operating personnel of the system, is mandatory!

Proceed as follows when commissioning the MultiControl Modular:

⚠ CAUTION

Steps 1-3 represent work to be carried out on site in preparation for commissioning.

Step 1:

Determination of the upper and lower working pressure. The upper working pressure is also the set pressure at the overflow valve.

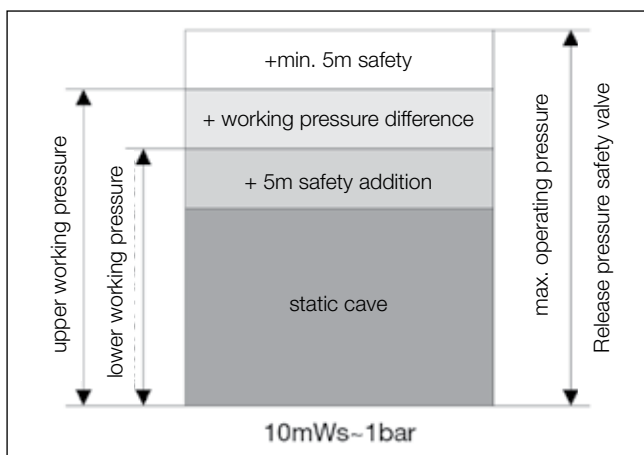

Figure 11: Determination of upper and lower working pressure

Step 2:

Shut off the lines from/to the system (expansion line, fresh water supply).

⚠ WARNING

But do NOT shut off the suction line and overflow line!

Step 3:

Fill and ventilate the system to the upper working pressure determined in step 1.

Step 4:

Check the hydraulic and electrical connections for correctness, especially the expansion line.

Step 5:

Open the fresh water supply to the MULTICONTROL on the EMCF backfeed module and set the pressure reducer to 1.5 bar to max. 2.0 bar.

Version A: Loosen the fixing screw (1) and set the pressure reducer to 1.5 bar - max. 2.0 bar. Then tighten the screw again to fix the setting of the pressure reducer (fig. 13).

Version B: The setting is made using the adjusting dial (2). If the EMCF backfeed module is installed at the factory, this is already set, see sealing strip on the valve (3) (fig. 14).

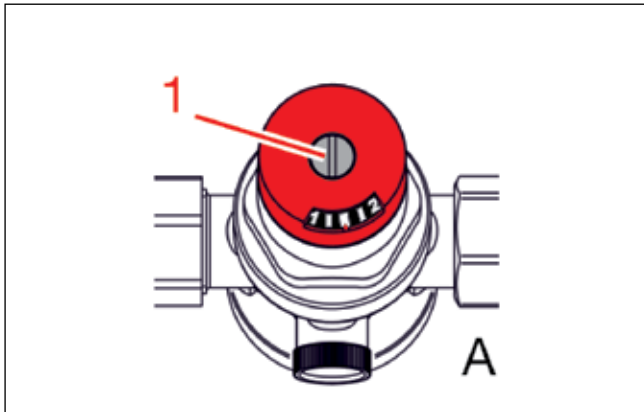

Figure 12: Pressure reducer on EMCF version A

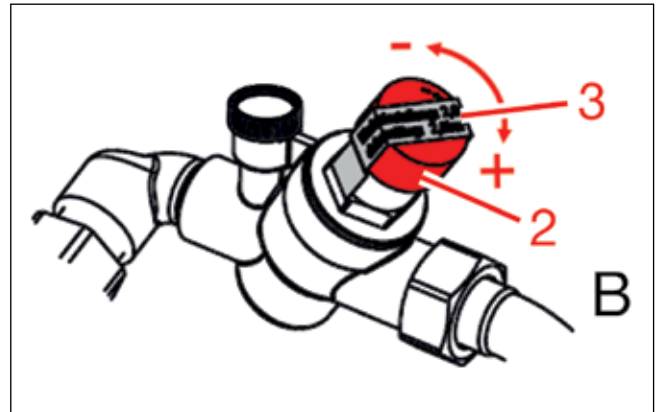

Figure 13: Pressure reducer on EMCF version B

Step 6:

Switch on the power supply and check whether the device function is deactivated. If necessary, switch off the device function using the activate device function button (system ON/OFF).

Step 7:

Settings in the device setup allow the touchscreen operating unit to be customised to the components in the device and its range of functions. Some of the settings possible in the device setup have already been preconfigured in the factory. Further settings are made during commissioning or, if necessary, in the course of a component extension or component replacement (service/maintenance).

Device setup: see touchscreen operating unit operating instructions, menu "Settings" "Device set-up".

i NOTE

For device set-up, see "Touchscreen operating unit operating instructions".

Step 8:

Filling and venting the pressurising pump(s) and the piping

- Fully open the shutoff valves on the pump extraction side and fully close the regulating valves on the pump pressure side.
- Open the bleed valve on the pressurising pump(s).
- With the EMCF backfeed module installed, switch to manual mode (operating level 3: Manual mode -> Outputs).
- Switch on the "backfeed valve" output and fill the tank with it until a continuous jet of the system medium emerges from the pump's vent valve, then set the "backfeed valve" output back to automatic mode (Auto "1").

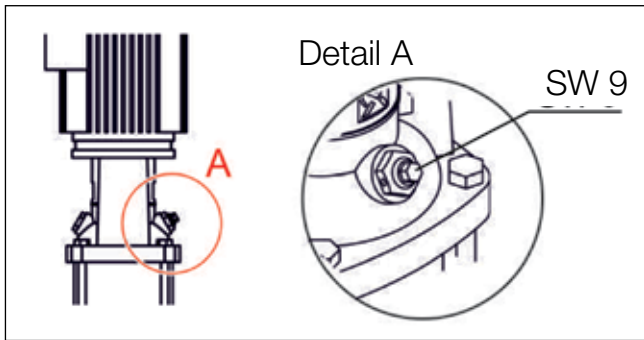

Figure 14: Venting valve on the pressure maintenance pump

i NOTE

Shut off all expansion tanks except the first main vessel beforehand to speed up the filling process.

- For devices without a built-in EMCF backfeed module, the vessel must be filled (e.g. via the KFE tap in the overflow line on the connection of the EG-M - see Figure 15, detail B) until a continuous jet of the system medium emerges from the pump vent valve (detail A). If necessary, reduce the factory-set upper working pressure at the overflow valve beforehand if the pressure in the system would otherwise rise too high (higher than the desired upper working pressure).
- Then switch the pressure maintenance pump on and off a few times in manual mode to achieve complete venting of the pump chambers ("Test" pump 1).

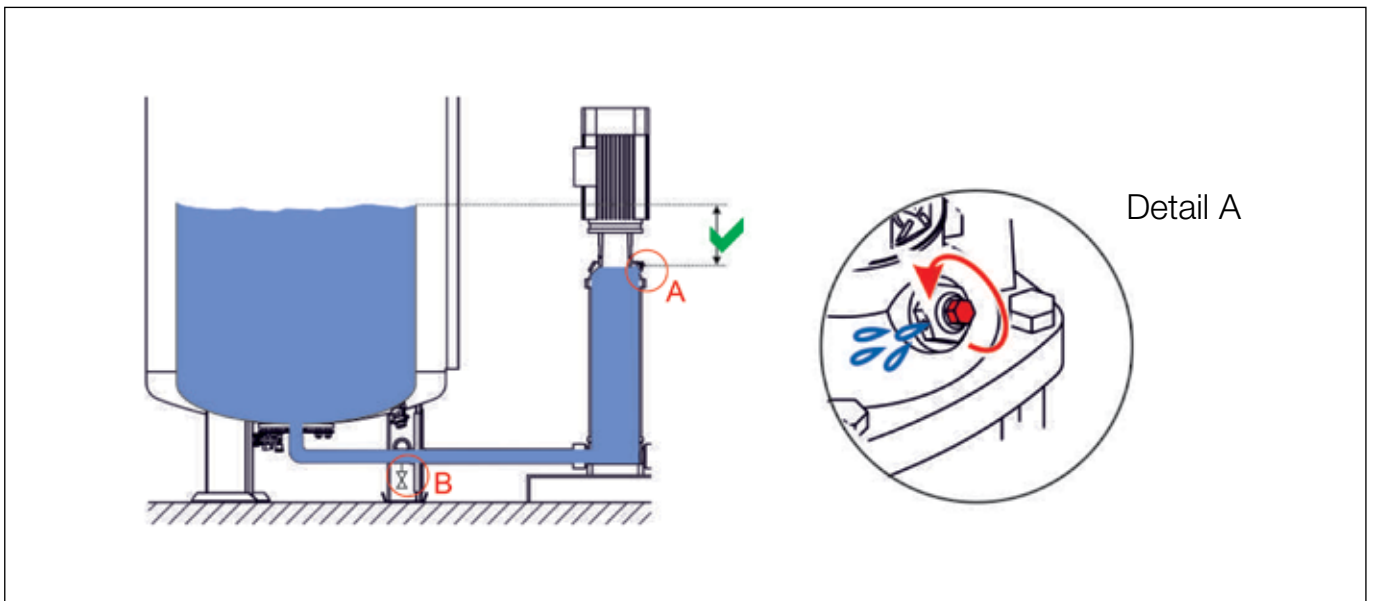

Figure 15: Venting valve on the pressure maintenance pump

- The direction of rotation of the pump motor must be checked at the same time. The motor fan wheel must rotate in the direction indicated on the motor cover. The fan wheel is visible through the holes in the motor cover. (Fig 16)
- If the direction of rotation is incorrect, 2 of the 3 phases in the on-site supply line to the device must be swapped in order to reverse the direction of the rotating field and thus the direction(s) of motor rotation.
- Close and tighten the pump venting valve again.
- For devices with 2 pressure maintenance pumps (DUO and MAXI models), follow the steps above for the 2nd pump. Repeat pump (front view: Pump 1=left, Pump 2=right).

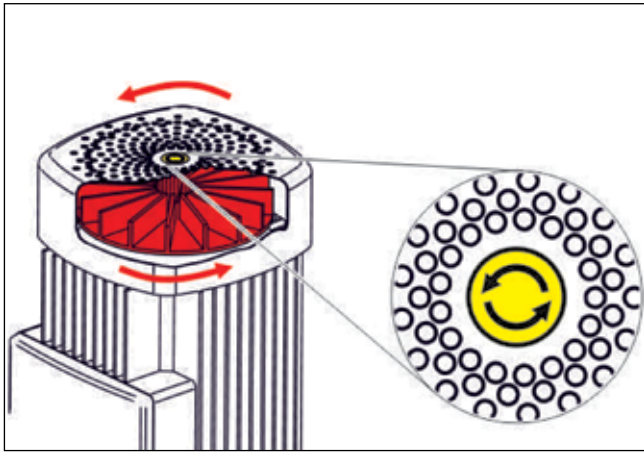

Figure 16: Checking the direction of rotation of the pump motor

Step 9:

Once the basic configuration has been completed and the pump(s) have been vented, switch on the device function using the activate device function button (system ON/OFF).



Step 10:

Depending on the working pressure to be set, it may be necessary to adjust the pressure maintenance pump(s) on the pressure side (characteristic curve-dependent increase in delivery rate with decreasing pressure). An indication that adjustment is necessary may be, for example, if the overflow valve only closes completely at more than approx. 0.5 bar below the upper working pressure after the pump(s) have been switched off.

The setting (1) of the pressure-side regulating valve(s) must be noted in the system or commissioning log.

Setting of regulating valve pump 1: _____

Setting of regulating valve pump 2: _____

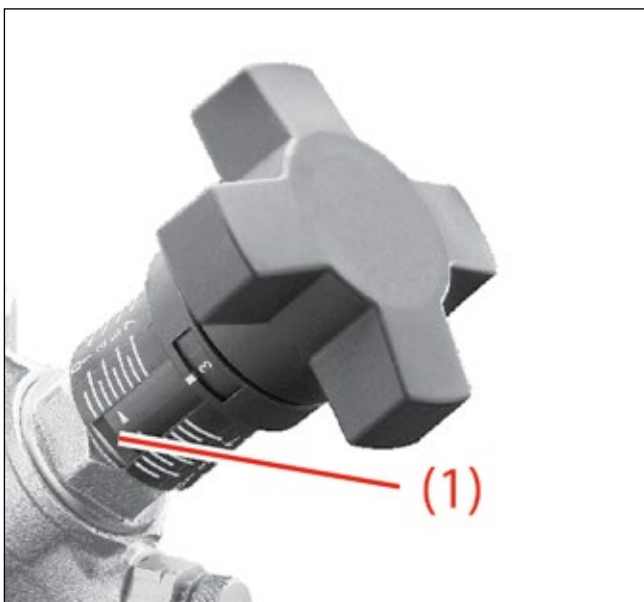

Figure 17: Adjusting the pressure-side regulating valve



CAUTION

The pressurising pump(s) must always be adjusted before the working pressure is set. After this, neither the working pressure nor the adjustment may be changed! If the pump(s) are subsequently adjusted, the working pressure must be set again.

Step 11:

Set the working pressure:

- Open the shut-off valves from/to the system (expansion line, fresh water). If the EMAE degassing module is installed, its ball valve on the inlet side must be closed. Depending on the size of the system, the pressure setting can take a long time, as the pressure must be propagated throughout the entire connected system in order to be sufficiently stable for the setting.
- Switch to operating level 3.



CAUTION

The connection from/to the system must be guaranteed for adjustment!

- Select "Settings" -> "Pressure maintenance" -> "Working pressure".
- The current setting is displayed; it corresponds to the last set working pressure (e.g. factory-set default values).



WARNING

Depending on the values displayed, the working pressure must always be set again during commissioning!

- After pressing the "CHANGE" button and confirming with "YES", the pump starts and the working pressure setting is active.
- Set the overflow valve to the upper working pressure determined in step 1. The currently measured pressure is displayed on the touchscreen of the Touchscreen operating unit.
Setpoint adjustment on the valve with: (a) black handwheel, (b) hexagon nut on the spring disc, (c) setpoint adjuster (design depends on the valve type installed).

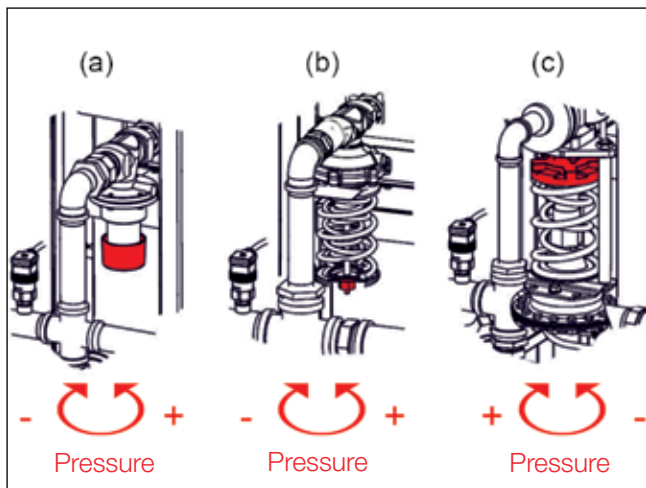

Figure 18: Adjusting the overflow valve

- For devices with two overflow valves (TWIN), the valves must be set individually one after the other. To do this, shut off one valve with the respective shut-off valves and set the pressure on the other valve. Then shut off the valve that has already been set, open the second valve and repeat the above steps (set both valves to the same pressure!).
- As soon as the desired value is stable for a few minutes, enter the working pressure difference (default setting: 0.5 bar). Difference between the upper working pressure set on the valve and the switch-on pressure of the pump (= lower working pressure).
- Accept the pressure setting using the OK button.



CAUTION

With TWIN devices, only one overflow valve may be in operation at any one time; the other must be shut off on the inlet side. If both overflow valves are operated at the same time, the control behaviour of the valves can be negatively influenced by each other (e.g. working pressure difference too large); this must therefore be avoided!

Step 12:

If the EMCF backfeed module is installed, the operating mode of the backfeed module must be selected. This operating mode depends on various factors, such as the size of the system, the age of the system, any known leaks, etc.

In the case of known regular leaks (e.g. if it is known that a certain quantity needs to be refilled within a certain time), we recommend the "Time-controlled" operating mode.

The description of the possible EMCF operating modes can be found in the operating instructions for the touchscreen operating unit.

Step 13:

If the EMAE degassing module is installed, the "Degassing module" operating mode must be selected. Incorrect selection will not guarantee correct degassing function!

One-off adjustment of the degassing module:

- Close the regulating valve and the ball valve on the degassing module.
- Switch to the Manual mode -> Outputs menu (operating level 3) and switch on the "Degassing valve" output (Manual "1").
- Wait until the motor valve is fully open (approx. 35 seconds; the scale or the red shaft on the linear actuator must no longer rotate).
- Opening the ball valve on the inlet side.
- Open the regulating valve slowly until a flow can be heard (1/4 turn). The system pressure drops and the pressure maintenance pump switches on.
- Monitor the system pressure on the touchscreen.
- The regulating valve is set correctly when 1 pump can build up the pressure again in a short time and switches off. If the pump does not switch off or, for DUO and MAXI models, the second pump switches on, the regulating valve is set incorrectly (open too wide).
- Then set the "Degassing valve" output back to automatic (Auto "1").
- The setting (1) of the regulating valve must be noted in the system or commissioning log.

Setting of EMAE regulating valve: _____

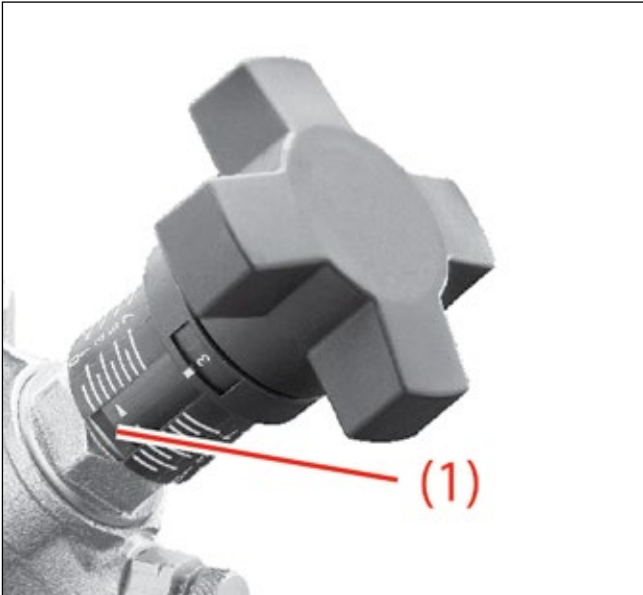

Figure 19: Adjusting of regulating valve MAE

Step 14:

The device is now ready for operation

The shut-off valves in the pipes from/to the system must be secured against unintentional closing (e.g. remove handles...).

Further settings (e.g. softening MWE, operating modes, etc.) can be made in the "Settings" menu of the touchscreen operating unit.

i NOTE

A detailed description of the function, operation, menu structures and display of the touchscreen operating unit can be found in the separate operating instructions.

8. CLEANING AND MAINTENANCE

8.1. Cleaning

During operation, dirt particles are separated from the system at the built-in strainer. These impurities are gathered in the strainer and are consequently lead to the reduced passage of the strainer. This may cause problems with the function of the device.



CAUTION

If problems with contamination occur frequently or constantly, further measures should be considered for the system (e.g. replacement and flushing of the system contents, installation of additional filters or sludge separators, etc.). These measures have a positive effect on all installed devices with direct contact with the medium, not just the pressurisation system.

The dirt particles separated by the strainer must therefore be removed at regular intervals by removing and cleaning the strainer screen. This inspection and cleaning of the strainer must be carried out at least twice a year! However, if there are any problems with the function of the device, the strainer must be cleaned first of all!

Problems and malfunctions caused by failure to clean the strainer as prescribed are excluded from any warranty claims.

8.2. Maintenance

The device must undergo maintenance at least once a year or when a warning "W03" is displayed! Carrying out this maintenance is the responsibility of the operator.



CAUTION

If the operator of the system is unable or unwilling to carry out this annual maintenance, appropriate specialist personnel or the Spirotech factory customer service must be commissioned to do so.



NOTE

It is recommended that maintenance is carried out by the Spirotech customer service centre. The conclusion of a maintenance contract is highly recommended.

Problems or malfunctions caused by non-compliance with the prescribed maintenance intervals or lack of maintenance are excluded from any warranty.

Work to be carried out in the course of maintenance:

- Check and document whether the regular cleaning according to 8.1 is carried out and document when this was last done; Carry out cleaning in any case!
- Ask the operator and document whether any abnormalities or problems have occurred since the last maintenance. These must be rectified if necessary!
- Check the check valve(s) for correct closure.
- Check the overflow valve for correct function and correct closing.

9. SPARE PARTS LIST

9.1. Piping

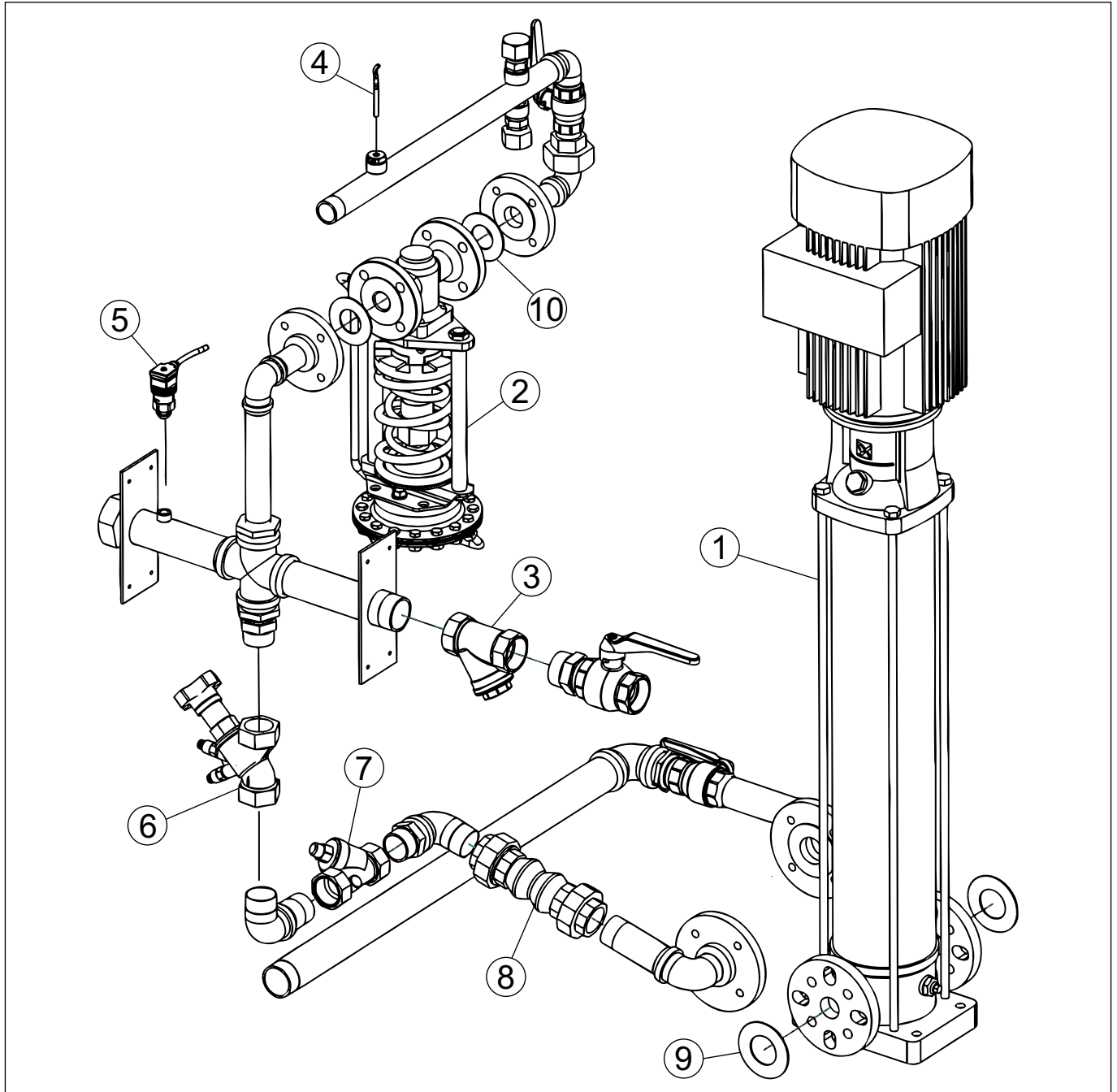

Figure 20: Spare parts for piping

POS.	DESIGNATION	SPARE PART ART. NO.												
	System SOLO	EMCM-S2-6.0	EMCM-S2-7.8	EMCM-S3-10.0	EMCM-S4-6.2	EMCM-S5-6.2	EMCM-S6-6.6	EMCM-S6-10.1	EMCM-S7-6.6	EMCM-S0.3-16.0	EMCM-S8-16.0	EMCM-S9-6.6	EMCM-S9-11.0	
1	Pressure maintenance pump	E90357	E90359	E90360	E90361	E90398	E90362							
2	Overflow valve	E90603	E90604	E90121	E90119	E90121	E90115	E90119	-	E90539	E90119	E90606		
3	Dirt trap	E90932			E90933				E90934	E90933				
4	Temperature sensor for MC	E90911												
5	System pressure transmitter	E90140												
6	Regulating valve	E90930			E90931				E90930	E90931				
7	Angle seat check valve	E90546			E90131				-	E90936	E90131			
8	Rubber compensator	E90937			E90116				-	E90938	E90116			
9	Seal for pressure maintenance pump	E90939			E90940				E90942	E90941				
10	Seal for overflow valve	-								E90942				

POS.	DESIGNATION	SPARE PART ART. NO.											
	System SOLO	EMCM-D2-6.6 EMCM-D2-6.6-TWIN	EMCM-D2-7.8 EMCM-D2-7.8-TWIN	EMCM-D3-10.4 EMCM-D3-10.4-TWIN	EMCM-D4-6.2 EMCM-D4-6.2-TWIN	EMCM-D5-6.2 EMCM-D5-6.2-TWIN	EMCM-D6-6.6 EMCM-D6-6.6-TWIN	EMCM-D6-10.1 EMCM-D6-10.1-TWIN	EMCM-D7-6.6 EMCM-D7-6.6-TWIN	EMCM-D8-16.0 EMCM-D8-16.0-TWIN	EMCM-D9-6.6 EMCM-D9-6.6-TWIN	EMCM-D9-11.0 EMCM-D9-11.0-TWIN	
1	Pressure maintenance pump	E90357	E90359	E90360	E90361	E90362							
2	Overflow valve	E90121	E90115	E90119	E90944	E90119	E90606	E90944	E90946	E90944	E90945		
3	Dirt trap	E90933			E90935	E90933	E90935	E90934	E90935				
4	Temperature sensor for MC	E90911											
5	System pressure transmitter	E90140											
6	Regulating valve	E90930			E90931								
7	Angle seat check valve	E90546			E90131				E90936	E90131			
8	Rubber compensator	E90937			E90116				E90938	E90116			
9	Seal for pressure maintenance pump	E90939			E90940				E90941	E90941			
10	Seal for overflow valve	-				E90943	-	E90943	E90941	E90943			

POS.	DESIGNATION	SPARE PART ART. NO.												
	System MAXI	EMCM-M2-6.0 EMCM-M2-6.0-TWIN	EMCM-M2-7.8 EMCM-M2-7.8-TWIN	EMCM-M3-10.0 EMCM-M3-10.0-TWIN	EMCM-M4-6.2 EMCM-M4-6.2-TWIN	EMCM-M5-6.2 EMCM-M5-6.2-TWIN	EMCM-M6-6.6 EMCM-M6-6.6-TWIN	EMCM-M6-10.1 EMCM-M6-10.1-TWIN	EMCM-M7-6.6 EMCM-M7-6.6-TWIN	EMCM-M0.3-16.0 EMCM-M0.3-16.0-TWIN	EMCM-M8-16.0 EMCM-M8-16.0-TWIN	EMCM-M9-6.6 EMCM-M9-6.6-TWIN	EMCM-M9-11.0 EMCM-M9-11.0-TWIN	
1	Pressure maintenance pump	E90357	E90359	E90360	E90361	E90398	E90362							
2	Overflow valve	E90603	E90604	E90121	E90119	E90121	E90115	E90119	-	E90539	E90119	E90606		
3	Dirt trap	E90933								E90934	E90933			
4	Temperature sensor for MC	E90911												
5	System pressure transmitter	E90140												
6	Regulating valve	E90930			E90931				E90930	E90931				
7	Angle seat check valve	E90546			E90131					E90936	E90131			
8	Rubber compensator	E90937			E90116				-	E90938	E90116			
9	Seal for pressure maintenance pump	E90939			E90940				E90942	E90941				
10	Seal for overflow valve	-								E90942				

9.2. Elektronik

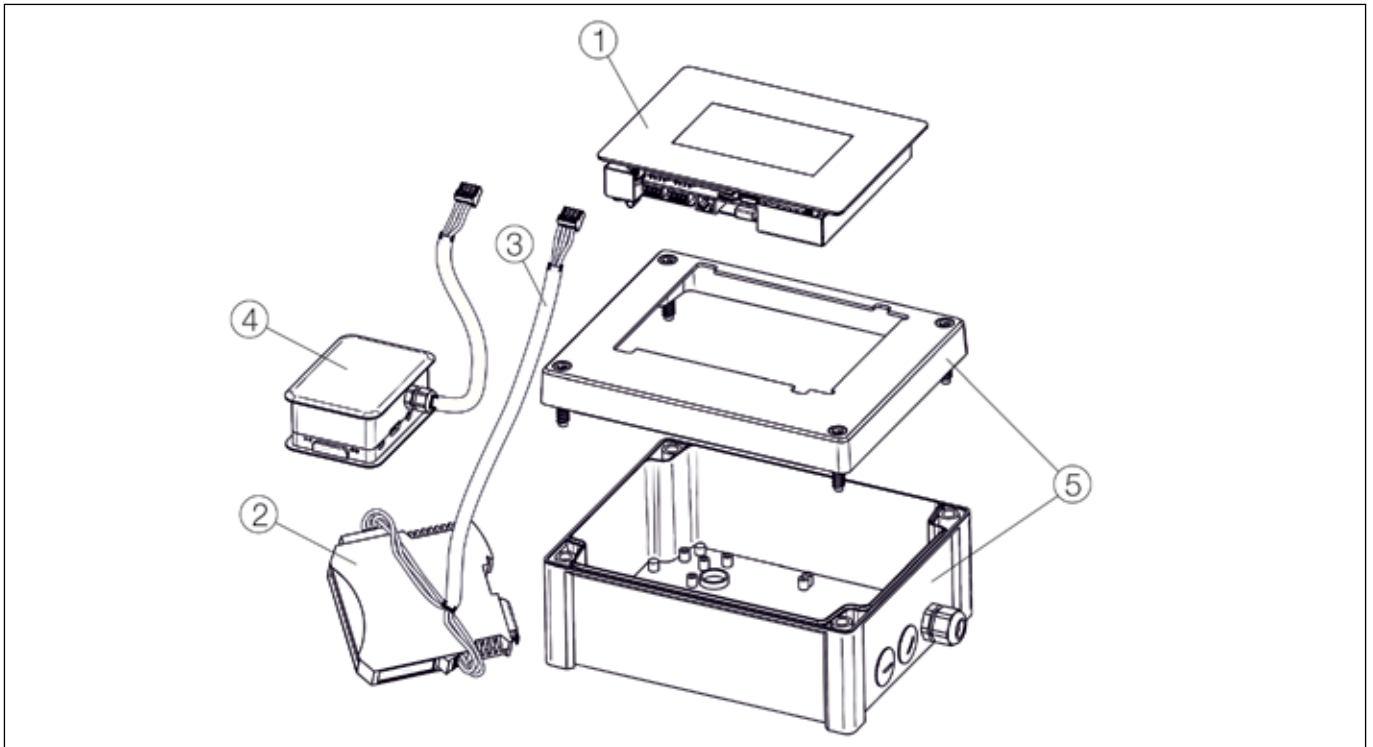

Figure 21: Spare parts control housing

POS.	DESIGNATION	SPARE PART ART. NO.
1	Touchscreen operating unit, type BCE49, incl. shielding plate	E90996
2	MultiControl Bus Module Profibus	(optionally available as an accessory)
2	MultiControl Bus Module Modbus RTU RS485	(optionally available as an accessory)
2	MultiControl Profinet Bus Module	(optionally available as an accessory)
2	MultiControl Bus Module Modbus TCP	(optionally available as an accessory)
3	Connection cabling for bus module	(included in the scope of delivery of the bus module)
4	MultiControl web module	(optionally available as an accessory)
5	Touchscreen operating unit - MULTICONTROL operating housing (base + cover), machined, empty	E90997



WARNING

Simultaneous use of bus module and web module is not possible!

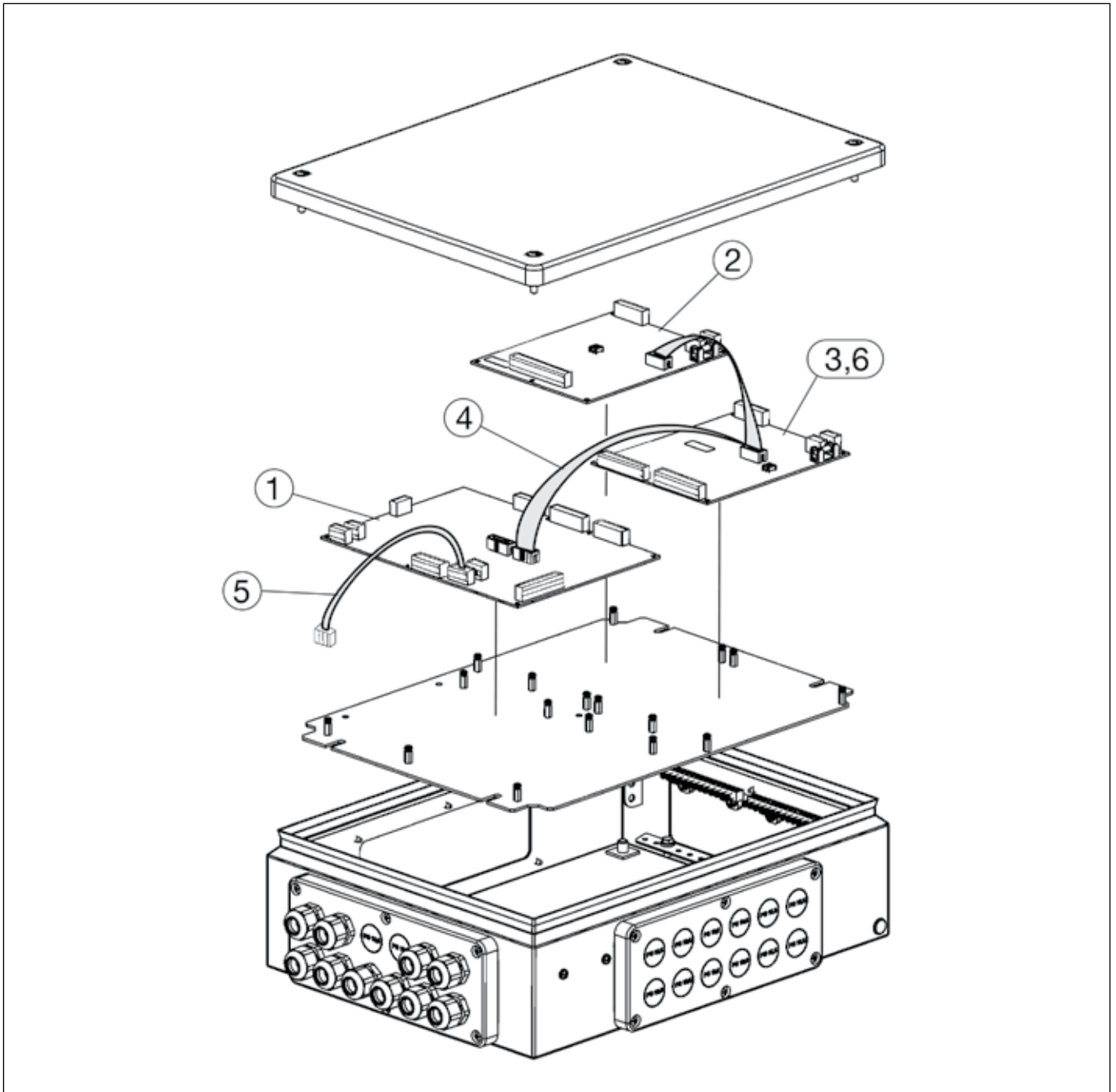

Figure 22: Spare parts switch cabinet

POS.	DESIGNATION	SPARE PART ART. NO.
1	Print - MultiControl motherboard, type 200331	E90903
2	Print - "Analogue remote signalling" expansion module	E90624
3	Print - "Binary remote signalling" expansion module	E90625
4	Connection cable motherboard-expansion board, 10-pole, 3 connectors	E90965
5	Connection cable 4-pole, shielded Motherboard operating unit, without plug	E90994
6	Print - Expansion module "Binary remote signalling & remote acknowledgement"	E90626

9.3. EMCF backfeed module

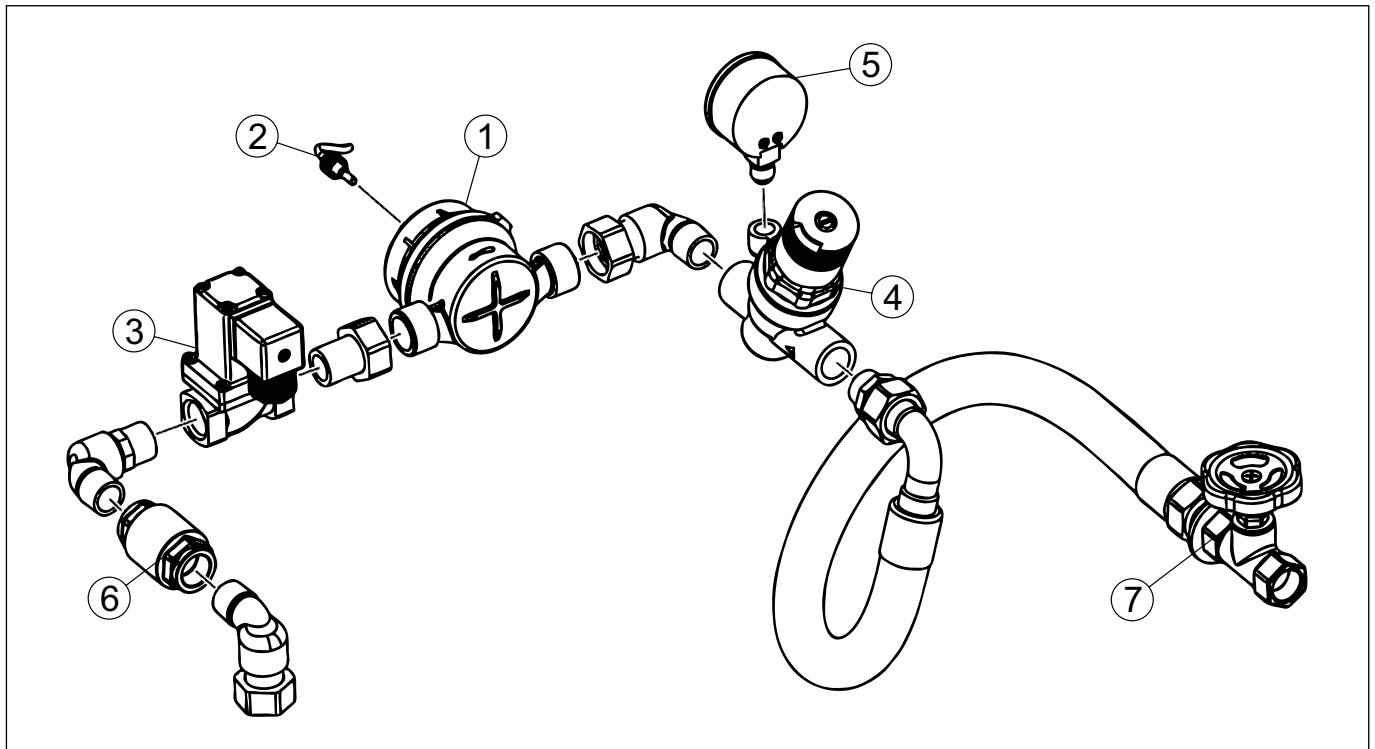

Figure 23: EMCF backfeed module

POS.	DESIGNATION	SPARE PART ART. NO.	
		EMCF-1	EMCF-3
1	Water meter 1.5 m ³ /h, version B Water meter 2.5 m ³ /h, version B	E90950 -	- E90951
2	Water meter contact module 1 litre/pulse plug-in, for meter version B	E90949	
3	Solenoid valve	E90575	E90038
4	Pressure reduction valve, ½", type D05; Version B Pressure reduction valve, ¾", type D05; Version B	E90952 -	- E90953
5	Pressure gauge - for EMCF (optional depending on version)	E90908	
6	Check valve	E90620	E90621
7	Flow valve with handwheel, ½" (EMCF-1) or ¾" (EMCF-3)	E90694	E90695

9.4. Degassing module EMAE

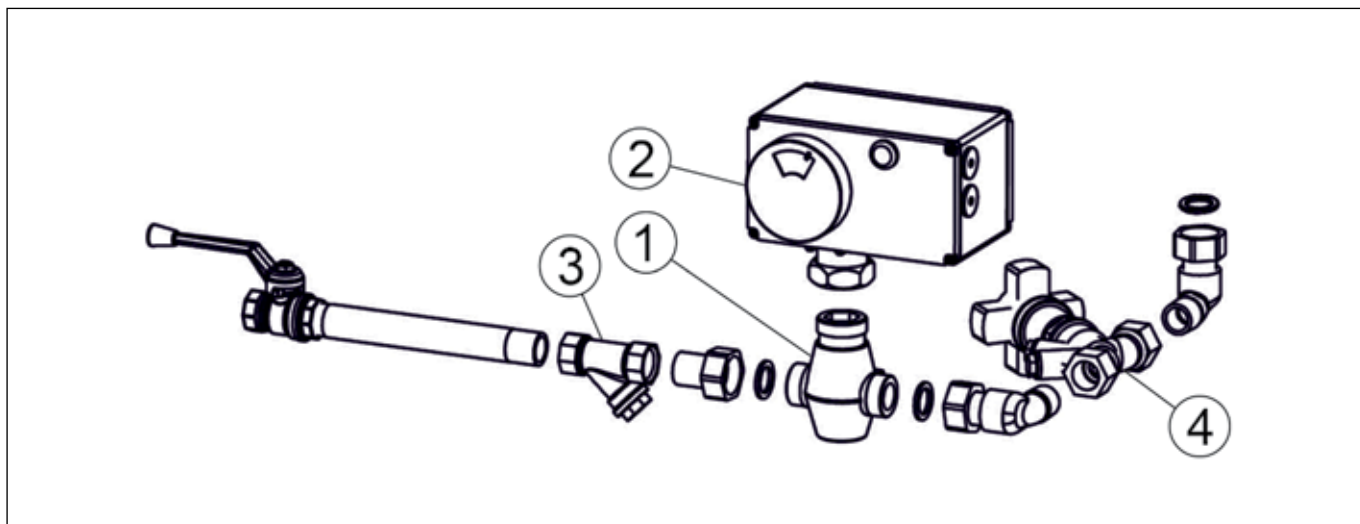

Figure 24: Degassing module EMAE

POS.	DESIGNATION	SPARE PART ART. NO.
		EMA-E-1
1	Control valve ½" PN25	E90926
2	Linear actuator for control valve ½" with safety function	E90927
3	Strainer ½" PN25	E90928
4	Regulating valve ½" PN25	E90929

9.5. Power section

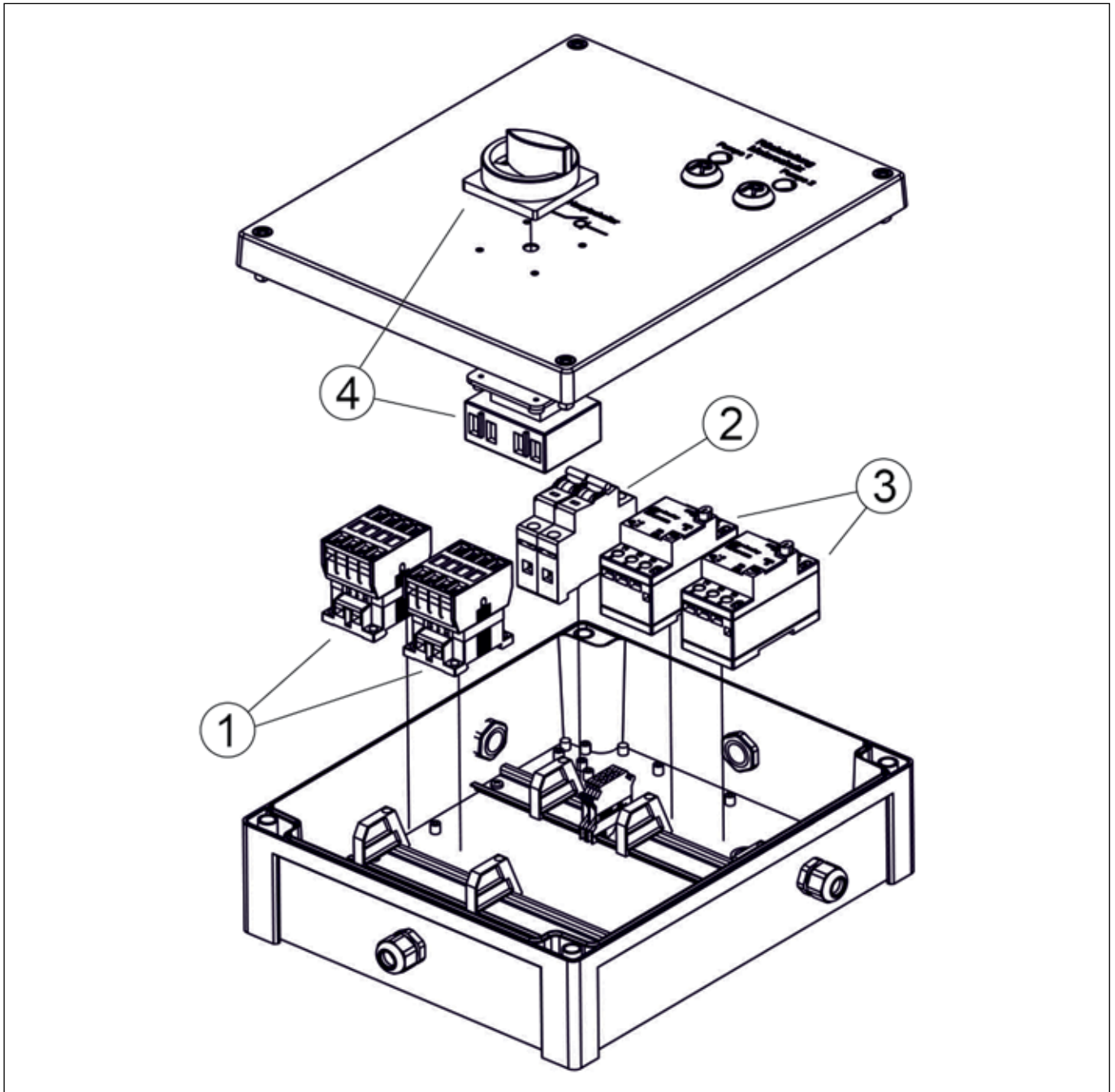





Figure 25: Power section

POS.	DESIGNATION	SPARE PART ART. NO.		
		EMCM-S2...5 EMCM-M2...5-TWIN EMCM-D2...5-TWIN	EMCM-S6...7 EMCM-M6...7-TWIN EMCM-D6...7-TWIN	EMCM-S8...9 EMCM-M8...9-TWIN EMCM-D8...9-TWIN
1	Power contactor min. 4.0 kW, coil 230V~/50Hz	E90919		
2	Automatic circuit breaker, 2-pole, N switched, 6 A	E90920		
3	Motor protection switch incl. auxiliary contact	4 A (2,5-4,0 A) E90921	6,3 A (4,0-6,3 A) E90922	10 A (6,3-10,0 A) E90923
4	Main switch, 4-pole, 32 A	E90924		

10. CERTIFICATES

10.1. CE declarations of conformity

		EG-Konformitätserklärung EC Declaration of Conformity			
im Sinne der Richtlinie(n):		in accordance with the directive(s):			
- 2006/42/EG über Maschinen		- 2006/42/EC on machinery			
- 2014/30/EU über die elektromagnetische Verträglichkeit		- 2014/30/EU relating to electromagnetic compatibility			
- 2014/35/EU über die Bereitstellung elektrischer Betriebsmittel zur Verwendung innerhalb bestimmter Spannungsgrenzen auf dem Markt		- 2014/35/EU relating to the making available on the market of electrical equipment designed for use within certain voltage limits			
- 2011/65/EU Verwendung bestimmter gefährlicher Stoffe in Elektro- und Elektronikgeräten (RoHS 2) gemäß Anhang II (gültig ab 22.07.2019) nach Änderungen der Richtlinie (EU) 2015/863		- 2011/65/EU use of certain hazardous substances in electrical and electronic equipment (RoHS 2) as per Annex II (valid from 22 July 2019) acc. to the amendments of the directive (EU) 2015/863			
Der Hersteller		The manufacturer			
Eder Spirotech GmbH Leisach 52 A - 9909 Leisach					
erklärt hiermit, dass das Produkt		declares hereby, that the product			
multicontrol modular MCM					
mit dem (optionalen) Zubehör		with the (optional) accessories			
Expansionsgefäß Nachspeisemodul Entgasungsmodul		elko-mat eder EG-M multicontrol MCF multicontrol MAE		expansion vessel makeup module degassing module	
entwickelt, konstruiert und gefertigt wurde in Übereinstimmung mit der/den oben genannten Richtlinie(n).		has been developed, designed and manufactured in compliance with the above listed directive(s).			
Folgende harmonisierten und nationalen Normen und Spezifikationen sind angewandt:		The following harmonised and national standards and specifications have been applied:			
- ÖNORM EN ISO 12100:2013 - ÖVE EN 60204-1:2019 - EN 61000-6-2:2005 - EN 61000-6-3:2007 +A1:2011 +AC:2012 EN 61326-1:2013 EN 61000-3-2:2014 EN 61000-3-3:2013 ÖNORM EN 60335-1:2012 + AC:2014 ÖVE ÖNORM EN 60730-1:2012					
Leisach, 03.02.2022 Ort, Datum		 Ing. Hans Jacobs, Geschäftsführer Unterschrift			

11. APPENDIX

11.1. Sizing the expansion line

Expansion lines are pipes that connect the system to the expansion and pressure maintenance system.

i NOTE

The design criterion is the nominal heat output to be dissipated, the maximum operating temperature and the flow velocity according to ÖNORM H 5151-1:2010 12 15.

Extract from **ÖNORM H 5151-1:2010 12 15:**

11.2.3.2 Sizing the expansion line (expansion line).

The following points must be observed when sizing the expansion line:

- The nominal heat output of the heat supply system applies to the sizing of the expansion line.
- For systems with a nominal heat output of less than 500 kW, the minimum nominal diameters can be retrieved from the adjacent table.

DN	NOMINAL HEAT OUTPUT IN KW
20	up to 120
25	over 120 to 500

Minimum nominal diameter of expansion lines

The maximum flow velocity in the expansion line must not exceed 0.15 m/s.

i NOTE

If the heat supply and heat distribution systems are separated, there may be a small volume of water in the heat supply system. It may therefore be necessary to size the expansion line using the maximum flow velocity.

The calculation of the flow velocity in the expansion line must be based on the percentage temperature-dependent increase in volume V_e from the filling water temperature (10°C) to the protection temperature θ_{TZ} and the total content of the system V_A .

The heating time t_A , which is required to reach the safety temperature θ_{TZ} and the total volume of the system V_A , is calculated according to equation A:

$$t_A = \frac{(V_A \cdot \Delta\theta_{TZ} \cdot c_W \cdot \rho_W)}{\Phi_N}$$

c_W	Spec. heat capacity of heating water at θ_{TZ}	[kJ/(kg · K)]
Φ_N	Nominal heat output	[kW]
ρ_W	Density of the heating water at θ_{TZ}	[kg/m ³]

Figure 26: Equation A

The expansion volume flow V_e is calculated according to equation B:

$$\dot{V}_e = \frac{V_e}{t_A \cdot 1000}$$

Figure 27: Equation B

The calculation inner diameter of the expansion line is calculated according to equation C:

$$d_{AI} = \sqrt{\frac{4 \cdot \dot{V}_e}{\pi \cdot v}} \cdot 1000$$

Figure 28: Equation C

The next larger nominal pipe diameter must be selected. The maximum pressure loss in the expansion line must not exceed 1 kPa.



CAUTION

Within the pressure maintenance system (overflow line, suction line), the manufacturer decides which flow velocities ensure problem-free functioning of the pressure maintenance system.

The maximum flow velocities are therefore 0.75 m/s in the overflow line and 0.50 m/s in the suction line.

11.2. Details on connecting EMCM with EP-R(S)

In devices from the MultiControl Modular series, there is no built-in expansion tank; the expansion volume is stored in expansion tanks from the EG-M series; the additional expansion vessel EGZ-M serves as a possible extension for this.

The individual devices must always be connected in accordance with the required hydraulic connection diagram in chapter 5.

To ensure proper functioning of the pressurisation system, the following instructions must be observed when connecting the EMCM to the EP-R(S)!

Ensure that the respective connections are connected correctly!

EP-R(S) expansion vessels have internals on the lower vessel flange that are required for proper degassing function.

Therefore, the overflow line of the EMCM control unit must always be connected to the overflow line on the expansion vessel. This must also be observed for the suction line!

i NOTE

- Overflow line EMCM = Overflow line EG-M
- Suction line EMCM = Suction line EG-M

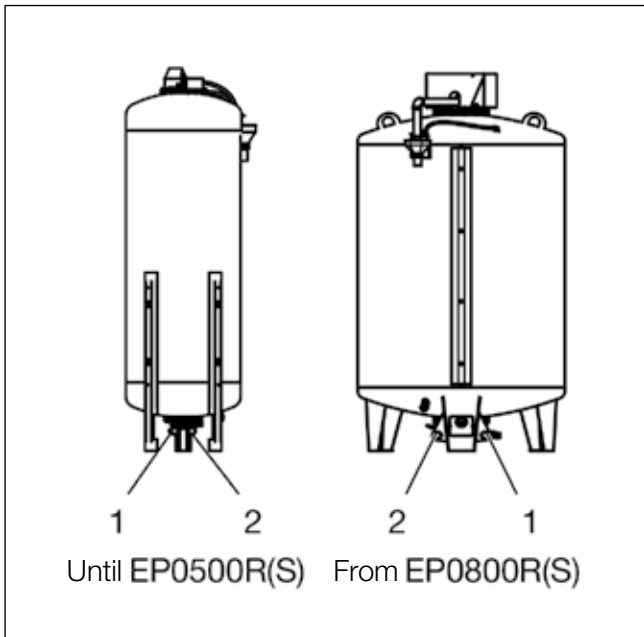

Figure 29: Overflow line (1) and suction line (2) of EP-R(S) expansion tanks

Laying the suction line

In some cases, it may be necessary to cross the overflow line and the suction line in order to connect the EMCM and EP-R(S) correctly. It is important to ensure that the suction line is laid without constant differences in level.

If level differences between the EMCM and EP-R(S) cannot be avoided, it must at least be ensured that the suction line from the EMCM to the EP-R(S) is routed upwards.

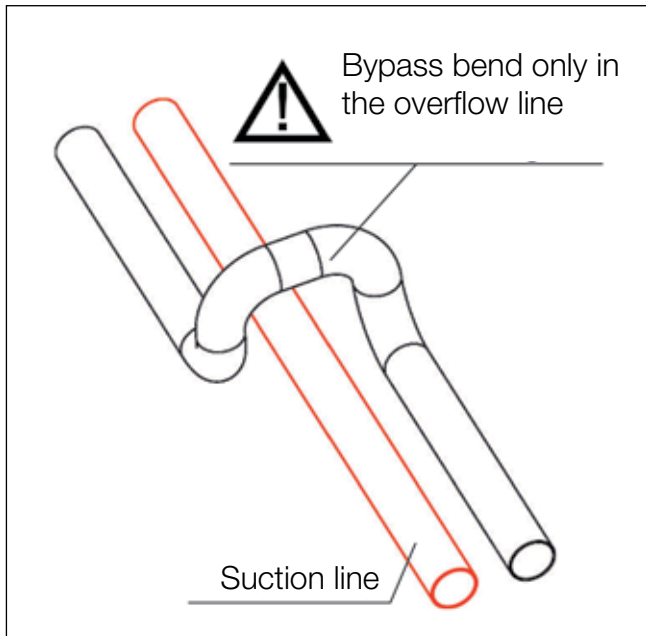

Figure 30: Laying the suction line



CAUTION

Avoidance bends, jump bends etc. required for the crossing may only be implemented in the overflow line. To ensure problem-free level compensation between the individual vessels, the suction line and overflow line must be laid close to the floor along their entire length!

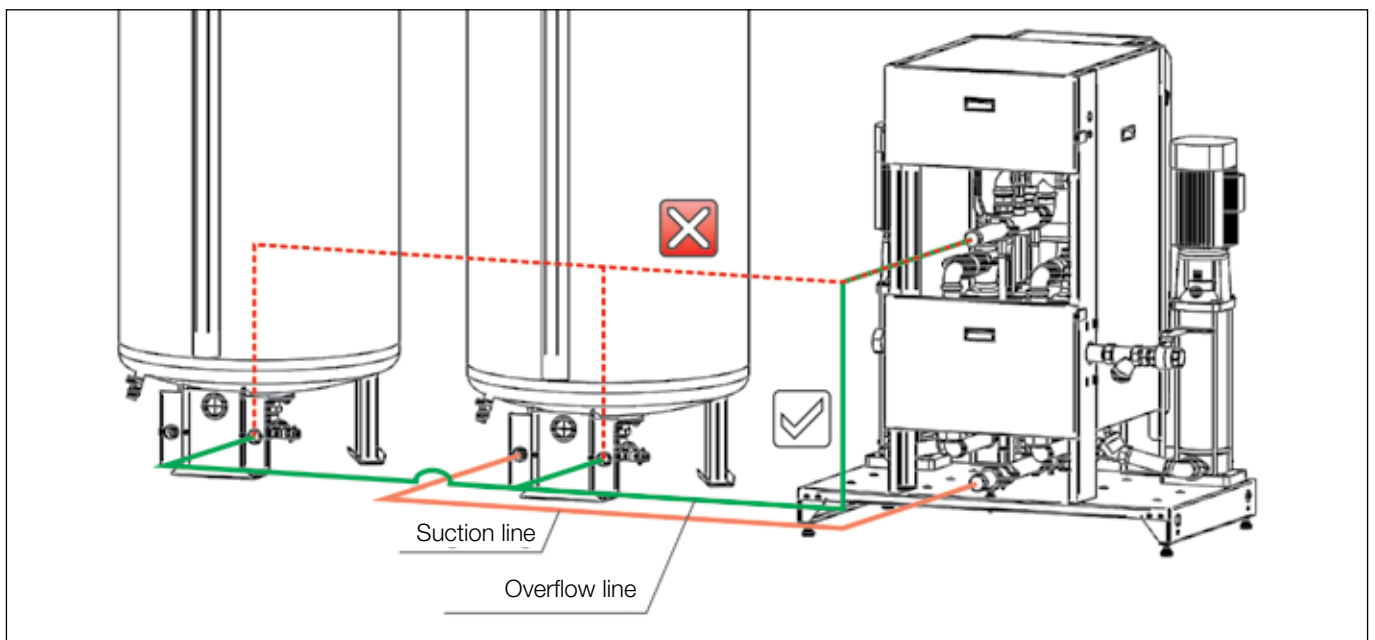
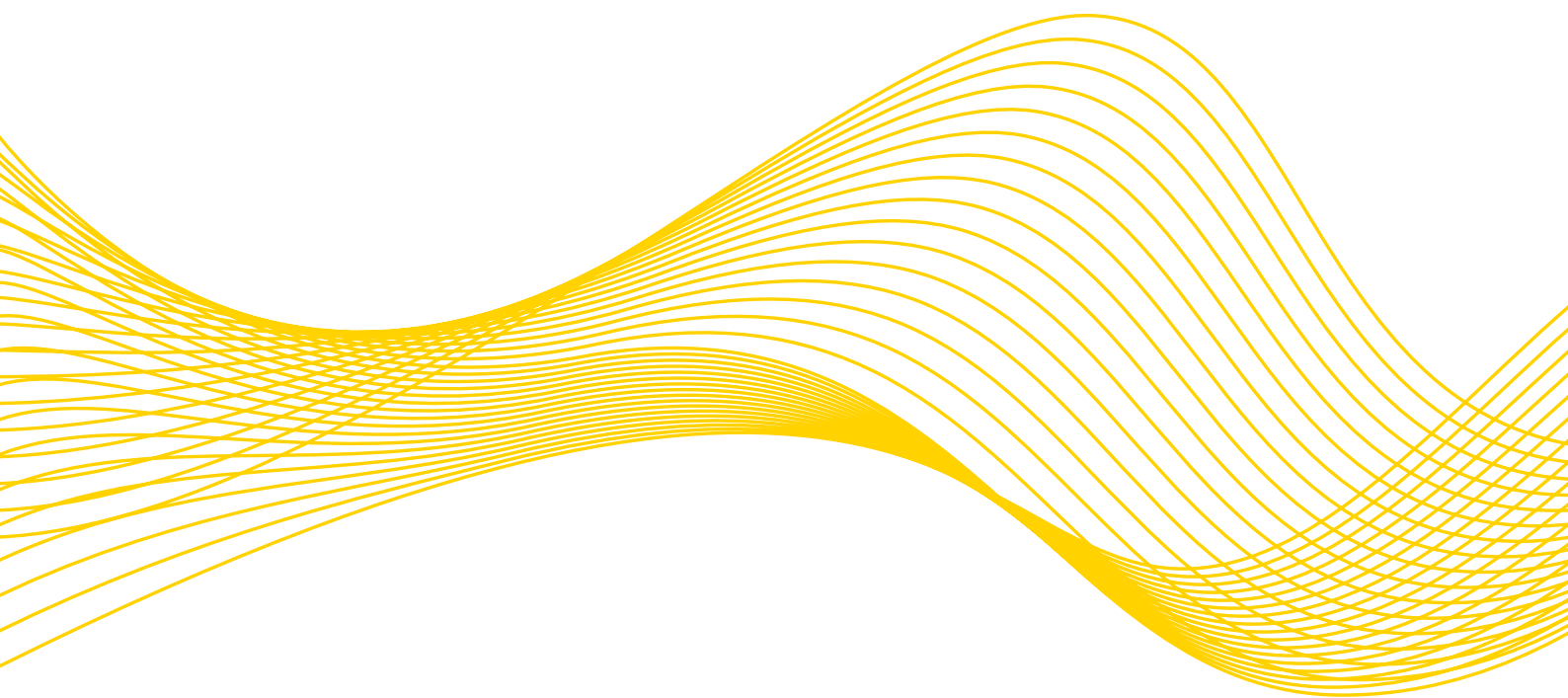

Figure 31: Laying the suction line and overflow line

MAXIMISING PERFORMANCE FOR YOU



Copyright ©

All rights reserved. No part of this manual may be reproduced and/or published on the Internet, by means of printing, photocopying, microfilm or in any other way without the prior written permission of Spirotech bv.

Spirotech bv

Postbus 207
5700 AE Helmond, NL
T +31 (0)492 578 989

www.spirotech.co.uk
www.spirotech.com