

# Motorised ball zone valves for air-conditioning systems

## 6452-6453 series



### Function

The zone valves perform the function of automatically shutting off the flow of the medium distributed to the system.

Complete with insulation, they are ideal above all for application in air-conditioning systems, characterized by particularly low working temperatures of the thermal medium with consequent condensation build-up.

The motorised ball valves are used in air-conditioning systems also thanks to the following features:

- possibility of being installed upside-down;
- possibility of being opened and closed thanks to the manual control lever on the actuator;
- no seepage;
- short operating times (valve opening/closing);
- operation with high differential pressures;
- low head losses.

### European directive conformity

CE mark directives 2006/95/EC and 2004/108/EC



### Product range

6452 series	Motorised two-way ball zone valve for air-conditioning systems	230 V (ac) or 24 V (ac)
		DN 20 (1/2" - 3/4"), DN 25 (1" - 1 1/4") with union
6453 series	Motorised three-way ball zone valve for air-conditioning systems	230 V (ac) or 24 V (ac)
		DN 20 (1/2" - 3/4"), DN 25 (1" - 1 1/4") with union
6459 series	By-pass tee for 6453 series motorised ball zone valves	
		DN 20 (1/2" - 3/4"), DN 25 (1" - 1 1/4") with union
6459 series	Shell insulation for 6453 series motorised ball zone valves with 6459 series by-pass tee	

### Technical specifications

#### Valve body

#### Materials

Body:	brass EN 12165 CW617N
Ball:	brass EN 12165 CW617N, chrome plated
Ball seal:	PTFE with EPDM O-Ring
Control stem seal:	double EPDM O-Rings
Union seal:	EPDM O-Ring

#### Performance

Medium:	water, glycol solutions
Max. percentage of glycol:	50%
Maximum working pressure:	10 bar
Maximum differential pressure:	10 bar

Ball passage:	reduced bore
Connections:	1/2", 3/4", 1", 1 1/4" M (ISO 228-1) with union
3-way bottom connection:	3/4" F (ISO 228-1)
By-pass tee top connection:	3/4" M (ISO 228-1)

### Ambient conditions (valve + actuator)

Medium working temperature range:	-10–110°C
Ambient temperature:	
Operation:	-10–55°C EN 60721-3-3 Cl. 3K4, max. humidity 95%
Transportation:	-30–70°C EN 60721-3-2 Cl. 2K3, max. humidity 95%
Storage:	-20–70°C EN 60721-3-1 Cl. 1K2, max. humidity 95%

### Technical specifications of actuator

Synchronous motor	
Electric supply:	230 V (ac) 24 V (ac)
Power consumption:	6 VA
Auxiliary microswitch contact rating:	6 (2) A (230 V)
Protection class:	IP 65
Operating time:	50 s (rotation 90°)
Supply cable length:	0,8 m
Dynamic torque:	9 N·m

### Technical specifications of insulation

Material:	closed cell expanded PE-X
Thickness:	15 mm
Density: - inner part:	30 kg/m³
- outer part:	80 kg/m³
Thermal conductivity (DIN 52612):	- at 0°C: 0,038 W/(m·K)
	- at 40°C: 0,045 W/(m·K)

Coefficient of resistance to the diffusion of water vapour (DIN 52615):	> 1.300
Working temperature range:	0–100°C
Reaction to fire (DIN 4102):	class B2

## Dimensions

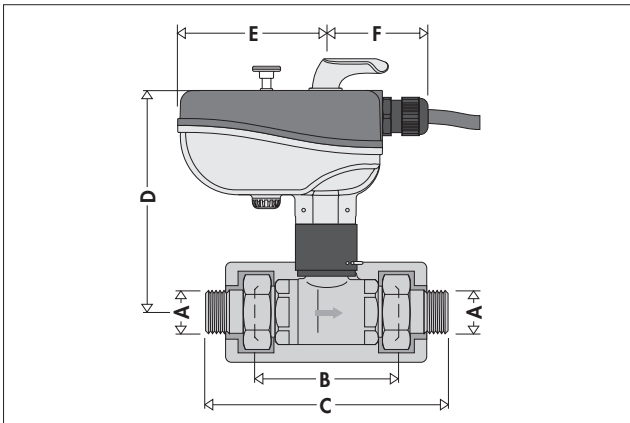

Codice	DN*	A**	B	C	D	E	F	Massa (kg)
645242/4	20	1/2"	84	141	129	85	59	1,43
645252/4	20	3/4"	84	141	129	85	59	1,52
645262/4	25	1"	96	177	129	85	59	1,97
645272/4	25	1 1/4"	96	177	129	85	59	2,00

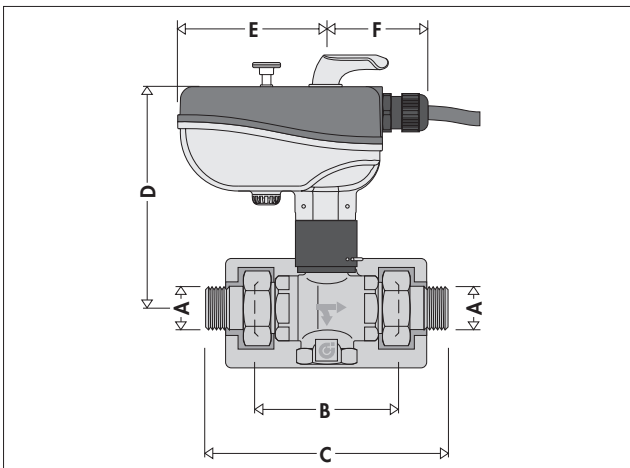

Codice	DN*	A**	B	C	D	E	F	Massa (kg)
645342/4	20	1/2"	84	141	129	85	59	1,50
645352/4	20	3/4"	84	141	129	85	59	1,50
645362/4	25	1"	96	177	129	85	59	2,00
645372/4	25	1 1/4"	96	177	129	85	59	2,00

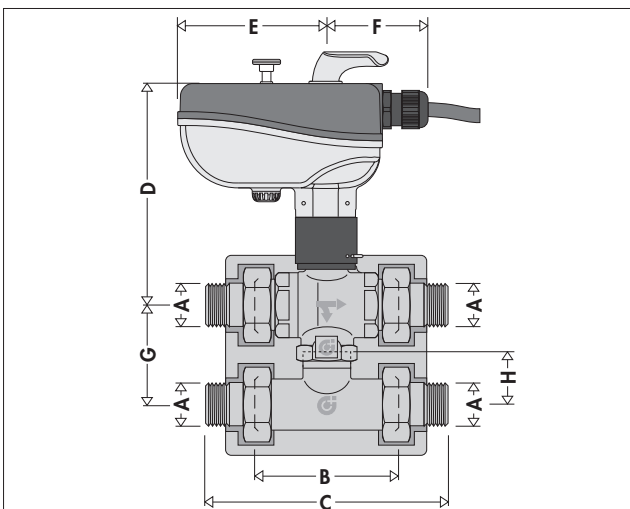

Codice	DN*	A**	B	C	D	E	F	G	H	Massa (kg)
64534.+645940	20	1/2"	84	141	129	85	59	60	38	2,03
64535.+645950	20	3/4"	84	141	129	85	59	60	38	2,03
64536.+645960	25	1"	96	177	129	85	59	60	32	2,83
64537.+645970	25	1 1/4"	96	177	129	85	59	60	32	2,86

\* Valve body  
\*\* Connections

## Operating principle

### Ambient temperature control in air-conditioning systems.

The increase in ambient temperature, in the summertime, causes the contacts of the room thermostat to close and the resulting electric supply of the actuator that drives the valve opening.

The circuit is thus supplied with refrigerated water and the zone is air-conditioned.

When the desired ambient temperature is reached, the thermostat causes the contact to open with the valve closing as a result.

The room thermostat, usually used also for the wintertime, must be the type with two positions (ON/OFF) and must be designed for the WINTER/SUMMER switchover.

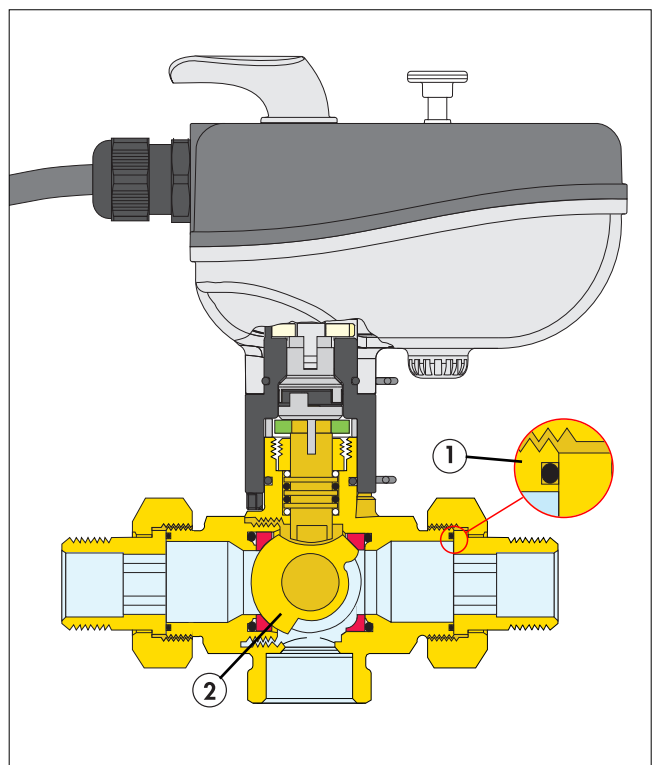
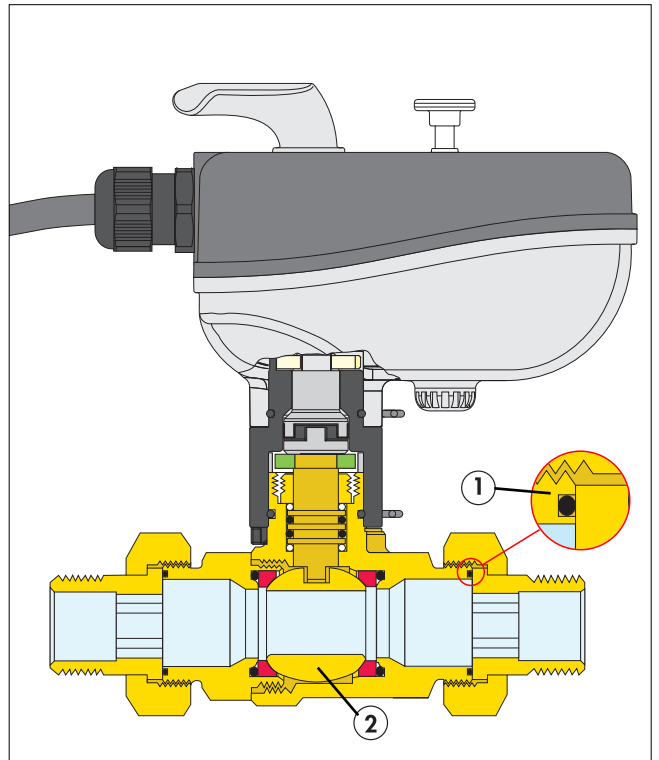

## Construction details

### Valve

The valve is equipped with a flat seat union with EPDM O-Ring seal ①. Using the ball shut-off mechanism ② enables high differential operating pressures and, when fully open, low head losses. The low torque values when opening/closing, together with an adequate actuator dynamic torque, make for short operating times.

### Actuator

#### Manual opening/closing

The actuator is equipped with a control lever (B), for valve manual opening/closing, that can be operated by pressing the button (A). The lever also acts as a position indicator.

The fixing of the actuator to the valve body, by means of a stainless steel clip ③, enables quick disassembly in order to check and operate the control stem of the ball with the aid of a screwdriver.

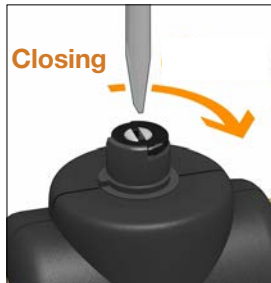
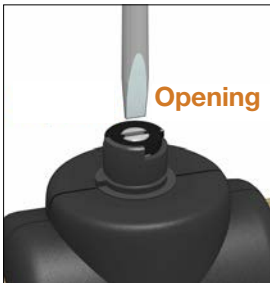
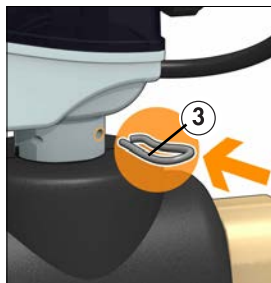
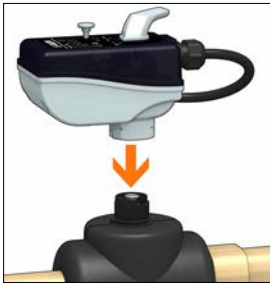
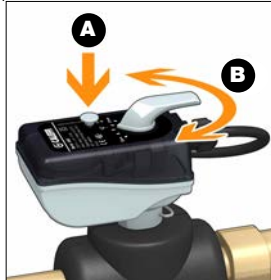

### IP protection class and material safety

The valve can be installed in a vertical, horizontal or upside-down position, as shown in the figure, as the actuator is certified with an IP 65 protection class.

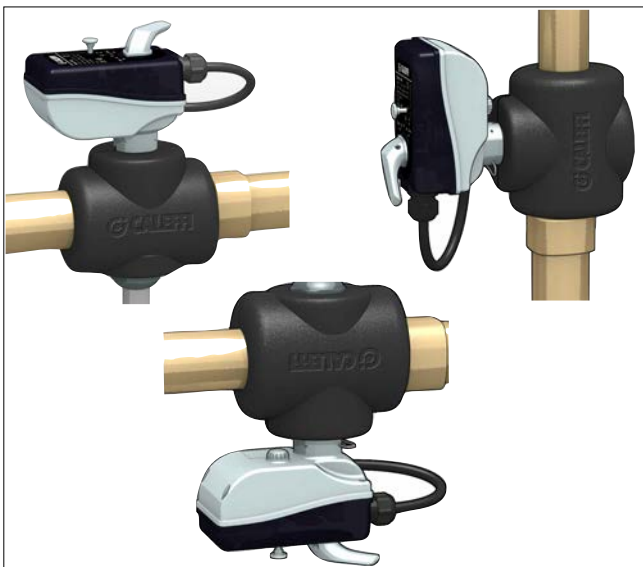

### Pre-formed insulation

This particular series of motorised ball zone valves is offered, above all, for the specific application on air-conditioning systems, thanks to the hot pre-formed shell insulation, supplied in the package, that prevents condensation build-up on the valve body surface. This system, moreover, ensures not only perfect thermal insulation, but also the resistance to the diffusion of water vapour from the ambient toward inside.

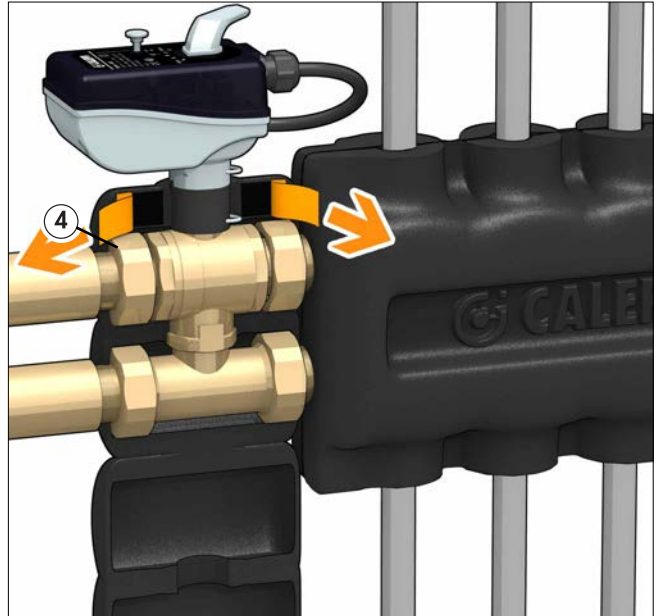

The 6459 series insulation (flow / return) must be used with the 6453 series valve when coupled to the 356 ...IS series cast monoblock dual distribution manifold. This assembly requires to eliminate the insulation supplied with the valves. The self-sticking labels ④ enable a quick fitting of the insulation without using fixing glues.

### Thermal decoupler

Between the valve body and the actuator there is a polymer thermal decoupler ⑤, which contains two stainless steel stems and a central insulating ring. This prevents the transmission of heat from/to the electric actuator. This heat is generated by the flow of the thermal medium in the valve. This prevents condensation build-up inside the actuator.



## Hydraulic characteristics

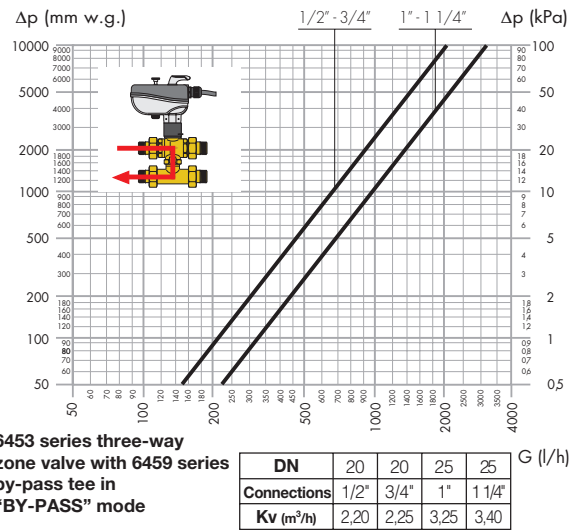
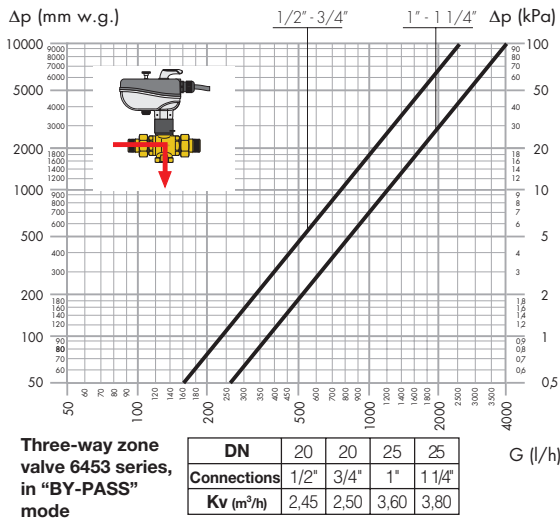
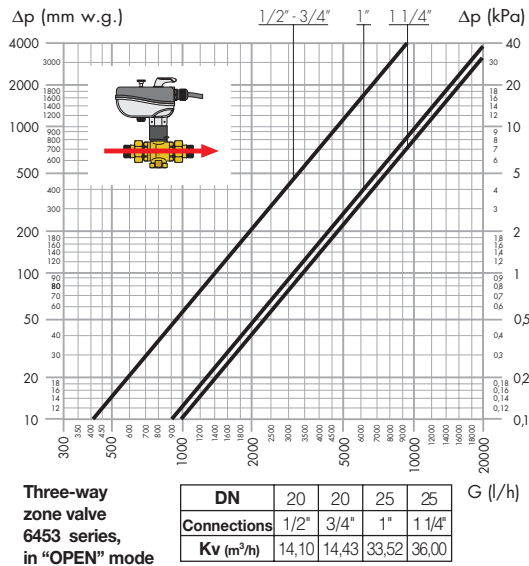
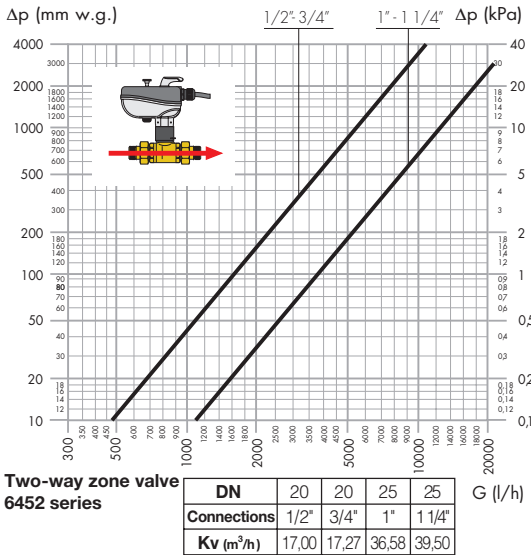

## Installation

The zone valve must be installed respecting the direction of water flow shown on the valve body.

The 6452 series two-way zone valves can be installed both on the return pipe and on the flow pipe.

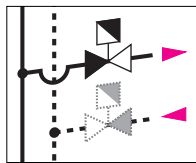

The 6453 series three-way zone valves and 6459 series three-way valves with by-pass must be installed on the flow pipe.

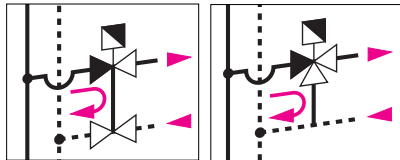

### Example of fitting the zone valve with the 663 IS series manifold

The figure shows an example of installation featuring the 6480 series off-centre kit connected to the 6459 series by-pass for coupling the 6453 series zone valve to the 663 IS series insulated single manifolds and the use of 6562 and 6564 series thermo-electric actuators.

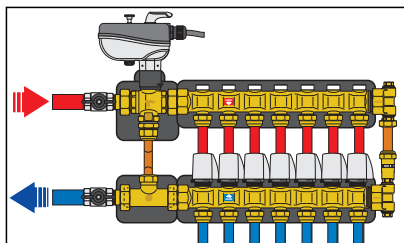

## Wiring diagrams

### Internal diagram with valve in the closed position

- R relay
- MC1 opening limit stop microswitch.
- MC2 closing limit stop microswitch.
- AUX. MICRO. auxiliary microswitch, ready for use.

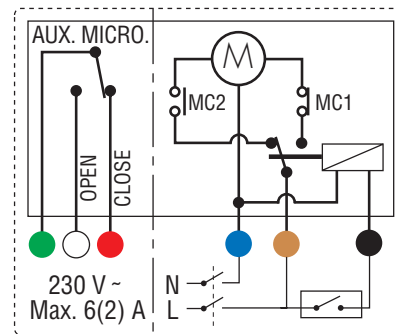

### Auxiliary microswitch

The actuator is equipped with an auxiliary microswitch for starting and stopping the pump. The closing switch over of the microswitch contacts occurs at about the 95% of the valve opening phase.

**Application diagrams**

**System with two-way zone valves and AUTOFLOW®**

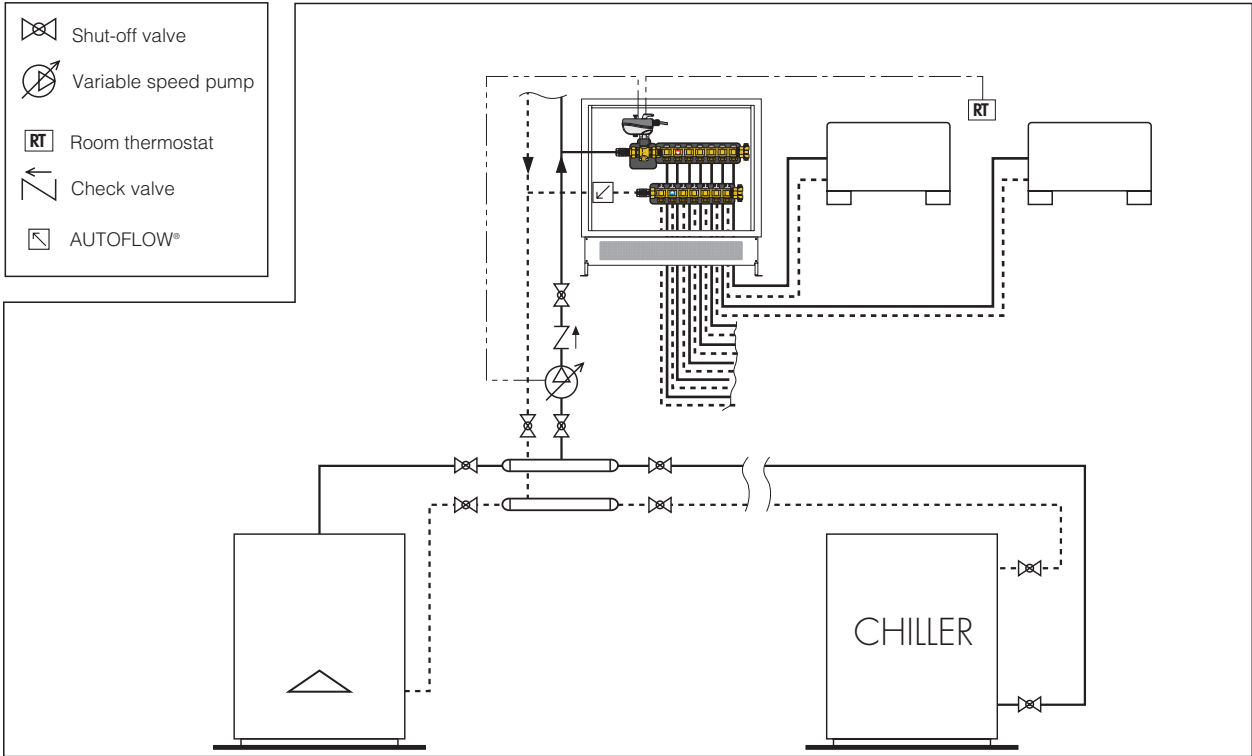

**System with three-way zone valves with by-pass tee and AUTOFLOW®**

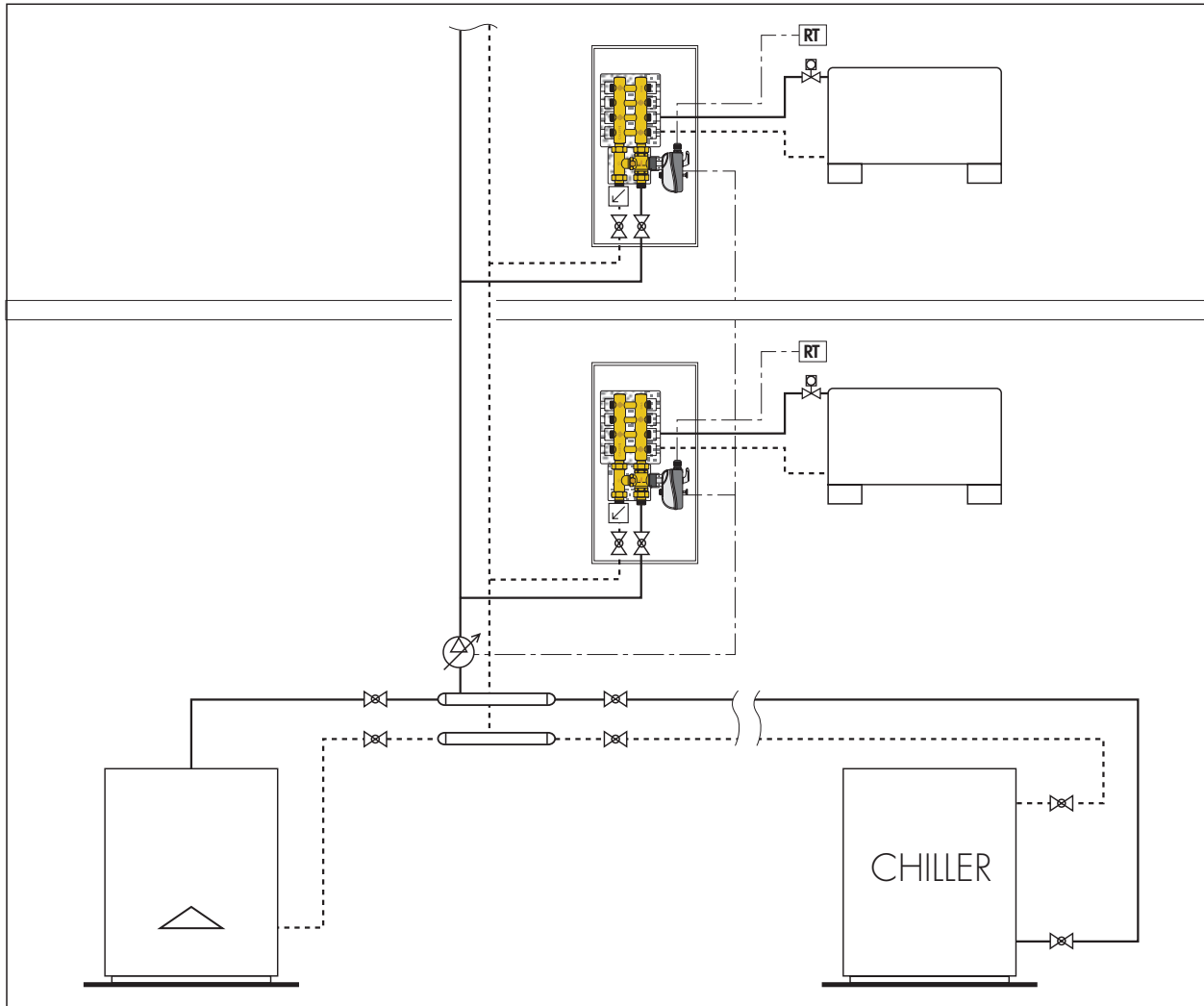

## SPECIFICATION SUMMARY

### 6452 series

Two-way motorised ball zone valve for air-conditioning systems. Sizes DN 20 (DN 20 and DN 25). Connections 1/2" (from 1/2" to 1 1/4") M (ISO 228-1) with union. Brass body. Chrome plated brass ball. Control stem seal with double EPDM O-Ring. PTFE ball seal with EPDM O-Ring for compensation of mechanical slack. EPDM O-Ring union seals. Medium water and glycol solutions; maximum percentage of glycol 50%. Maximum working pressure 10 bar. Maximum differential pressure 10 bar. Actuator electric supply 230 V (ac) or 24 V (ac); power consumption 6 VA; with auxiliary microswitch, auxiliary microswitch contact rating 6 (2) A (230 V); dynamic torque 9 N·m. Operating time 50 seconds (rotation 90°). Protection class IP 65. Electric supply cable length 0,8 m. Ambient conditions for valve with actuator: medium working temperature range -10–110°C; ambient temperature: operation -10–55°C EN 60721-3-3 Cl. 3K4, maximum humidity 95%; transportation: -30–70°C EN 60721-3-2 Cl. 2K3, maximum humidity 95%; storage: -20–70°C EN 60721-3-1 Cl. 1K2, maximum humidity 95%. Complete with closed cell expanded PE-X hot pre-formed shell insulation.

### 6453 series

Three-way motorised ball zone valve for air-conditioning systems. Sizes DN 20 (DN 20 and DN 25). Connections 1/2" (from 1/2" to 1 1/4") M (ISO 228-1) with union; bottom connection 3/4" F (ISO 228-1). Brass body. Chrome plated brass ball. Control stem seal with double EPDM O-Ring. PTFE ball seal with EPDM O-Ring for compensation of mechanical slack. EPDM O-Ring union seals. Medium water and glycol solutions; maximum percentage of glycol 50%. Maximum working pressure 10 bar. Maximum differential pressure 10 bar. Actuator electric supply 230 V (ac) or 24 V (ac); power consumption 6 VA; with auxiliary microswitch, auxiliary microswitch contact rating 6 (2) A (230 V); dynamic torque 9 N·m. Operating time 50 seconds (rotation 90°). Protection class IP 65. Electric supply cable length 0,8 m. Ambient conditions for valve with actuator: medium working temperature range -10–110°C; ambient temperature: operation -10–55°C EN 60721-3-3 Cl. 3K4, maximum humidity 95%; transportation: -30–70°C EN 60721-3-2 Cl. 2K3, maximum humidity 95%; storage: -20–70°C EN 60721-3-1 Cl. 1K2, maximum humidity 95%. Complete with closed cell expanded PE-X hot pre-formed shell insulation.

### 6459 series

By-pass tee for 6453 series motorised ball zone valves for air-conditioning systems. Size DN 20 (DN 20 and DN 25). Connections 1/2" (from 1/2" to 1 1/4") M (ISO 228-1) with union; top connection 3/4" M (ISO 228-1). Brass body. EPDM O-Ring union seals. Medium water and glycol solutions; maximum percentage of glycol 50%. Maximum working pressure 10 bar. Maximum differential pressure 10 bar. Medium working temperature range -10–110°C. Complete with closed cell expanded PE-X hot pre-formed shell insulation.

### 6459 series

Shell insulation for 6453 series motorised ball zone valves with 6459 series by-pass tee. Thickness 15 mm. Density: inner part: 30 kg/m<sup>3</sup>; outer part: 80 kg/m<sup>3</sup>; thermal conductivity (DIN 52612): at 0°C 0,038 W/(m·K); at 40°C 0,045 W/(m·K). Coefficient of resistance to the diffusion of water vapour (DIN 52615): >1,300. Working temperature ranges 0–100°C. Reaction to fire (DIN 4102) class B2.

*We reserve the right to change our products and their relevant technical data, contained in this publication, at any time and without prior notice.*