

## ONETRACK SUPPLY SUSPENSION BOX WHITE SET-RS/W2 9200820

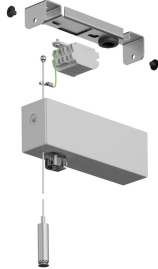

### Features

- OneTrack accessory, complete supply box including white metal cup (134x33x53mm), terminal block, 2675/SP/43 with earth wire, and ceiling bracket for installation. Compatible with Lytespan.



### Product Overview

|                            |  |
|----------------------------|--|
| <b>Product name</b>        | ONETRACK SUPPLY SUSPENSION BOX WHITE SET-RS/W2 |
| <b>Technology</b>          | Accessory                                      |
| <b>Mount</b>               | Ceiling surface mounting                       |
| <b>General application</b> | Museums & Galleries, Office                    |
| <b>ETIM Class</b>          | EC002556                                       |
| <b>Housing colour</b>      | White  |
| <b>Product EAN number</b>  | 4012289008208                                  |
| <b>Warranty</b>            | 5 years  |

### Technical drawings

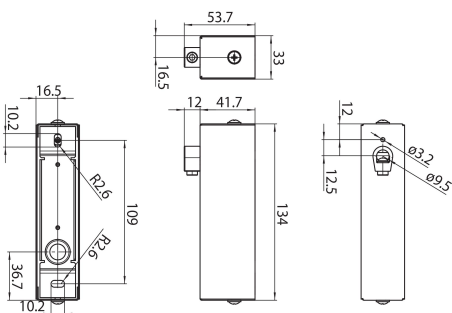

## ONETRACK SUPPLY SUSPENSION BOX WHITE SET-RS/W2 9200820

### Data table

#### GENERAL DATA

|                     |  |
|---------------------|--|
| Product name        | ONETRACK SUPPLY SUSPENSION BOX WHITE SET-RS/W2 |
| Technology          | Accessory                                      |
| Accessory type      | Mounting                                       |
| Type of accessory   | Installation set                               |
| Mount               | Ceiling surface mounting                       |
| General application | Museums & Galleries, Office                    |
| ETIM Class          | EC002556                                       |
| Warranty            | 5 years  |

#### ELECTRICAL DATA

|  |     |
|--|-----|
| Control gear required  | No  |
| Connectable conductor cross section - Max (mm <sup>2</sup> ) | 2.5 |

#### PHYSICAL DATA

|                             |       |
|-----------------------------|-------|
| Housing colour              | White |
| Nominal Product Length (mm) | 134   |
| Nominal Product Width (mm)  | 33    |
| Nominal Product Height (mm) | 53.7  |
| Weight (kg)                 | 0.06  |

#### PACKAGING

|                                       |               |
|---------------------------------------|---------------|
| Product EAN number                    | 4012289008208 |
| Packaging single length / height (cm) | 16.0          |
| Packaging single width (cm)           | 10.0          |
| Packaging single depth (cm)           | 10.0          |
| Units per outer package               | 1             |
| Packaging outer length / height (cm)  | 16.0          |

## ONETRACK SUPPLY SUSPENSION BOX WHITE SET-RS/W2 9200820

---

|                            |      |
|----------------------------|------|
| Packaging outer width (cm) | 10.0 |
| Packaging outer depth (cm) | 10.0 |

### SAFETY DATA

---

|                                     |    |
|-------------------------------------|----|
| Special purpose lamp                | No |
| Dry applications use only           | No |
| Suitable for household illumination | No |