

## Data Sheet | Item Number: 771-6993/206-501

pre-assembled connecting cable; Eca; Plug/open-ended; 3-pole; Cod. A; H05VV-F  
3G 1.5 mm<sup>2</sup>; 5 m; 1,50 mm<sup>2</sup>; black

<https://www.wago.com/771-6993/206-501>



Color: ■ black

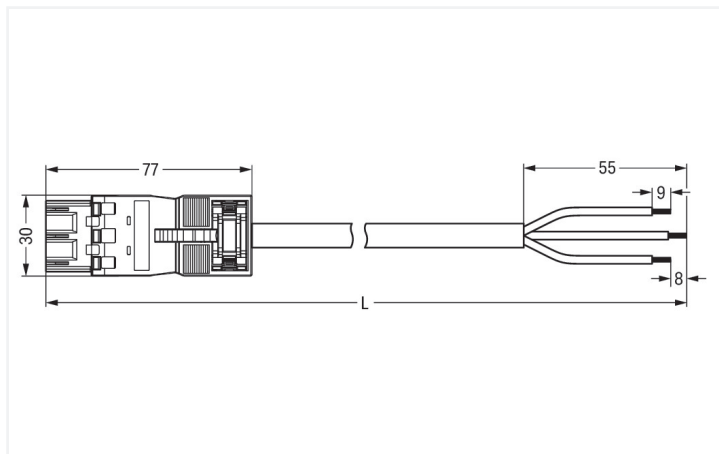

Dimensions in mm

### Cable assembly WINSTA® MIDI A coding

The WINSTA® MIDI cable assembly 3-pole is the pluggable solution for your application in control cabinets, on PCBs or for lighting connections. Our pluggable installation connectors with spring pressure connection technology function entirely without screw connections. They allow fast, efficient, error-free installation in a large number of possible uses. The coding options reduce installation errors, allowing fast, secure wiring of all components. Thanks to the color coding and mechanical A coding of WINSTA® MIDI pluggable installation connectors, you can clearly distinguish different circuits. The WINSTA® MIDI Pluggable Connection System with Push-in CAGE CLAMP® spring pressure connection technology facilitates precise electrification. Due to the built-in test slot, connections can be checked even when they are plugged in. That saves time and reduces installation labor and costs. Of course, the safety of buildings must always be ensured, even after the electrical installation has been performed. The required safety requirements in connection with EU CPR are fully satisfied by this product through fire class E.

### Fast, secure pluggable connections – cable assemblies from WAGO

The cable assembly is provided with a plug and a free end. The WINSTA® Pluggable Connection System allows pluggable electrical installation. This significantly reduces the need for servicing and lowers costs. Take advantage of the pluggable version of our maintenance-free spring pressure connection technology too! Plan your installation with with fire class E from WAGO.

- protection against mismatching eliminates errors
- simple circuits
- with A coding for use in many general mains applications
- ready for immediate use
- fast, secure installation

### Notes

Note Cables with a different fire class can be found in the eShop.

### Electrical data

Rated per	IEC/EN 60664-1		
Overvoltage category	III	III	II
Pollution degree	3	2	2
Nominal voltage	250 V	-	-
Rated impulse withstand voltage	4 kV	-	-
Rated current	16 A	-	-

### General information

Note on contact resistance approx. 1 mΩ of contact resistance  
approx. 0.25 mΩ contact transition plug/  
socket

## Connection Data

Total number of potentials	3
PE function	Preceding PE contact
Conductor preparation	ultrasonically tip-bonded

### Connection 1

Strip length	9 mm / 0.35 inches
Pole number	3
Wire cross-section	1.5 mm <sup>2</sup>
Strip length (outer insulation)	55 mm
Connection type	Plug - free end

## Physical data

Pin spacing	10 mm / 0.394 inches
Width	30 mm / 1.181 inches
Height	12.9 mm / 0.508 inches
Total length	5 m

## Mechanical data

Use	General mains applications
Coding	A
Variable coding	Yes
Marking	L ⊕ N
Potential marking	L ⊕ N
Mating force of a plug-in connection	approx. 20 ... 70 N (depending on pole number)
Retention force of a plug-in connection	when locked: > 80N
Unmating force of a plug-in connection	when unlocked: approx. 20 ... 70 N (depending on pole number)
Number of mating cycles	200, without resistive load
Connection type	Plug - free end
Type of pre-assembled cable	Connecting cable
Cable type	H05VV-F 3G1.5
Protection type	IP2XD; When mated: IP2xC (These compact connectors are not designed for use in open, easily accessible areas!)

## Plug-in connection

Mismating protection	Yes
Note on mismating protection	All WINSTA® components are 100% protected against mismating when: a.) plugging different numbers of poles b.) plugging while rotated 180 c.) plugging while laterally staggered d.) plugging one pole
Locking lever	Can be retrofitted
Locking of plug-in connection	Locking lever
Note on locking system	All connectors for mounted installations (snap-in versions for lighting fixtures or devices, all types of PCB and distribution connectors) are factory-equipped with locking levers to ensure plugs and sockets are securely locked. Additional locking levers are only required for flying leads (plug/socket).

### Material data

Note (material data)	<a href="#">Information on material specifications can be found here</a>
Color	black
Insulation material (main housing)	Polyamide (PA66)
Fire class per EN 50575	E <sub>ca</sub>
Contact material	Copper or copper alloy; surface-treated
Contact Plating	Tin
Fire load	150.031 MJ
Connector color	black
Strain relief color	black
Sheathed cable color	black
Printing color of sheathed cable	white
Halogen-free	No
Silicon-free	Yes
Sheath material	PVC
Rubber cable	No
Weight	508.6 g
Copper weight of the raw cable	0.043 kg/m

### Environmental requirements

Processing temperature	-5 ... +40 °C
Continuous operating temperature	-35 ... +85 °C
Note on continuous operating temperature	Cable for temperatures ≤ 70 °C (including halogen-free) Insulating parts for temperatures ≤ 105 °C

### Commercial data

PU (SPU)	1 pcs
Packaging type	unpacked
Country of origin	DE
GTIN	4050821522676
Customs tariff number	85444290900

### Product Classification

UNSPSC	26121629
eCl@ss 10.0	27-44-06-04
eCl@ss 9.0	27-44-06-04
ETIM 9.0	EC002587
ETIM 10.0	EC002587
ECCN	NO US CLASSIFICATION

### Environmental Product Compliance

RoHS Compliance Status	Compliant, No Exemption
------------------------	-------------------------

## Approvals / Certificates

### General approvals



Approval	Standard	Certificate Name
CCA DEKRA Certification B.V.	IEC 61535	NTR NL-7355
KEMA/KEUR DEKRA Certification B.V.	EN 61535	71-123834

### Declarations of conformity and manufacturer's declarations

Approval	Standard	Certificate Name
EU-Declaration of Confor- mity WAGO GmbH & Co. KG	-	-
UK-Declaration of Confor- mity WAGO GmbH & Co. KG	-	-

## Downloads

### Environmental Product Compliance

#### Compliance Search

Environmental Product  
Compliance  
771-6993/206-501



## Documentation

### Bid Text

771-6993/206-501	19.02.2019	xml 3.04 KB	
771-6993/206-501	14.01.2015	doc 26.50 KB	

## CAD/CAE-Data

### CAE data

EPLAN Data Portal  
771-6993/206-501



WSCAD Universe  
771-6993/206-501



## 1 Compatible Products

### 1.1 Required Accessories

#### 1.1.1 Locking system

##### 1.1.1.1 Locking system



[Item No.: 770-101](#)

Locking lever; for flying leads; for manual operation; black

[Item No.: 770-121](#)

Locking lever; for flying leads; for manual operation; white

[Item No.: 770-111](#)

Locking lever; for flying leads; for tool operation; black

[Item No.: 770-131](#)

Locking lever; for flying leads; for tool operation; white

## 1.2 Optional Accessories

### 1.2.1 Cover

#### 1.2.1.1 Cover



**Item No.: 770-360**

Lockout cap; for plugs; 5-pole; separable;  
yellow

## 1.2.2 Installation

### 1.2.2.1 Mounting accessories



**Item No.: 770-310**

Mounting carrier; 2- to 5-pole; for flying  
leads; black

## 1.2.3 Marking

### 1.2.3.1 Marking strip



**Item No.: 210-334**

Marking strips; as a DIN A4 sheet; Strip  
width 5 mm; Strip length 182 mm; plain;  
Self-adhesive; white