

Walraven W-LX-H Concrete Screw

(L0355)

ultimate performance zinc-plated concrete screws for anchoring in cracked and non-cracked concrete

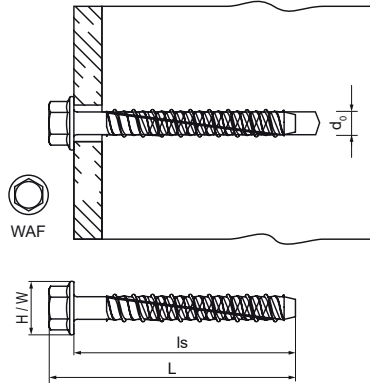

Features & benefits

- very high load capacity
- up to 3 anchoring depths provide maximum installation and design flexibility
- reduced edge and anchor spacing distances
- unique tip and thread geometry prevents concrete spalling
- material: steel
- zinc plated
- fire resistance class R30-R120
- seismic performance categories C1 and C2 (Ø 8/10/14)
- complies with VdS CEA 4001:2014-04 (05) and VdS CEA 4001:2018-01 (06) for applications with sprinkler systems in concrete elements
- substrate type: cracked concrete, non-cracked concrete, precast pre-stressed hollow core slabs
- for loads and more information, refer to the product data sheets and/or the ETA reports



Product Number	VVS Number	Screw Length	Anchor Size	Width Across Flats	Drill Hole Diameter	Total Height	Total Width	Total Length
Reference letter		<i>ls</i>		<i>WAF</i>	<i>d0</i>	<i>H</i>	<i>W</i>	<i>L</i>
Unit description		mm		mm	mm	mm	mm	mm
62430304	018049361	40	6	10	6	14	14	47
62430306	018049362	60	6	10	6	14	14	67
62430308	018049363	75	6	10	6	14	14	82
62430406	018049372	60	8	13	8	18	18	68
62430408	018049373	75	8	13	8	18	18	83
62430410	018049375	100	8	13	8	18	18	108
62430412	018049376	120	8	13	8	18	18	128
62430507	018049383	65	10	15	10	22	22	74
62430509	018049384	90	10	15	10	22	22	99
62430510	018049385	100	10	15	10	22	22	109
62430608	018049393	75	12	16	12	27	27	87
62430610	018049395	100	12	16	12	27	27	112
62430713	018049403	135	14	19	14	32	32	148