

## Walraven W-LX-PX Concrete Screw

(L0357)

zinc-plated concrete screw with a  $\varnothing 17.0$  mm pan head and torx T30 drive

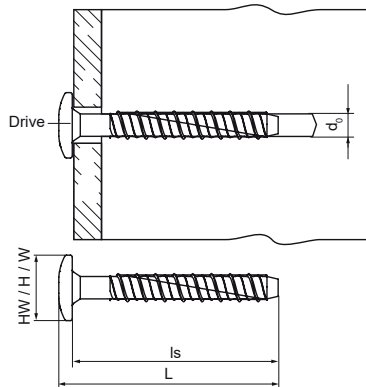

### Features & benefits

- very high load capacity
- approved for use in precast prestressed hollow core slabs
- up to 3 anchoring depths provide maximum installation and design flexibility
- reduced edge and anchor spacing distances
- removable
- unique tip and thread geometry prevents concrete spalling
- material: steel
- zinc plated
- fire resistance class R30-R120 for design of anchorages under exposure to fire
- complies with VdS CEA 4001:2014-04 (05) and VdS CEA 4001:2018-01 (06) for applications with sprinkler systems in concrete elements
- substrate type: cracked concrete, non-cracked concrete, precast pre-stressed hollow core slabs
- for loads and more information, refer to the product data sheets and/or the ETA reports



Product Number	Screw Length	Anchor Size	Key Driver Size	Drill Hole Diameter	Head Width	Total Height	Total Width	Total Length
Reference letter	ls		Drive	d0	HW	H	W	L
Unit description	mm			mm	mm	mm	mm	mm
62432304	40	6	T30	6	17	17	17	44
62432306	60	6	T30	6	17	17	17	64