

**Data Sheet | Item Number: 750-965**  
**Fieldbus Connector CC-Link; with D-sub male connector; 9-pole**

<https://www.wago.com/750-965>

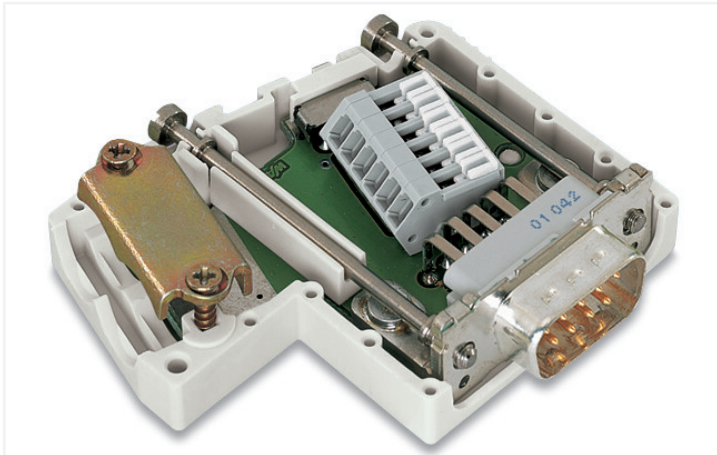

Color: ■ light gray

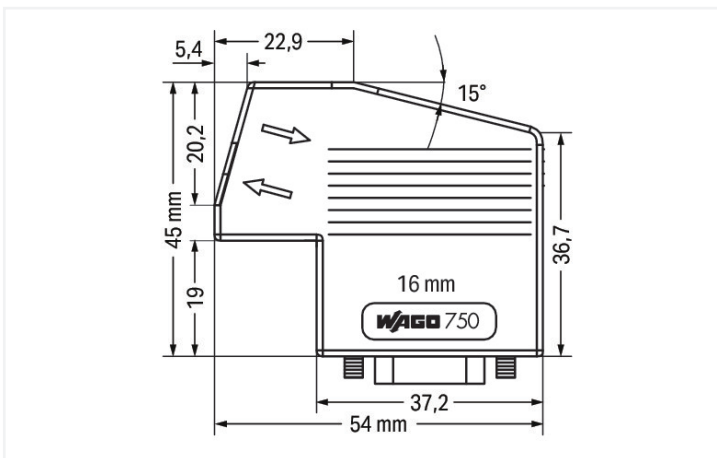
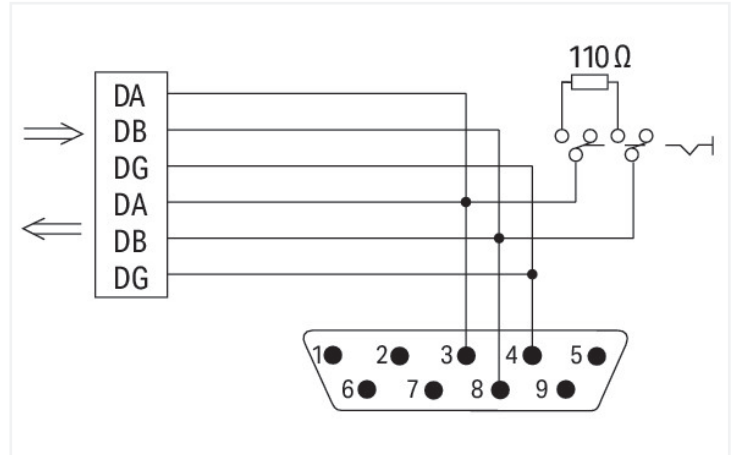

Dimensions in mm

This fieldbus connector links a CC-Link device to a CC-Link line.

The fieldbus connector has the following features:

- Two horizontal cable entries for both input and output
- Fast and maintenance-free CAGE CLAMP® connection – a locking slide keeps the clamping unit in its open position
- Externally operable switch to activate or deactivate the network terminating resistor
- For the first and last station on the bus, the switch must be set to "ON" (Terminating resistor activated)  
 Switch setting to "OFF" for downstream bus stations (Terminating resistor deactivated)

**Technical data**

Connection type	D-sub 9 plug
Pole number	9
Communication/fieldbus	CC-Link
Baud rate	-

### Connection data

Connection type 1	CAGE CLAMP® terminal strip with locking slide (218 Series)
Solid conductor	0.08 ... 0.5 mm <sup>2</sup> / 28 ... 20 AWG
Strip length	5 ... 6 mm / 0.2 ... 0.24 inches

### Physical data

Width	45 mm / 1.772 inches
Height	16 mm / 0.63 inches
Depth	54 mm / 2.126 inches

### Mechanical data

Connectable sheathed cable diameter	4.5 ... 9.5 mm
Cable glands (number)	2
Housing material	PA66-105-V2
Weight	34.1 g
Color	light gray

### Environmental requirements

Ambient temperature (operation)	0 ... +60 °C
Ambient temperature (storage)	-25 ... +85 °C
Protection type	IP20
Relative humidity (without condensation)	95 %
Fire load	0.29 MJ

### Commercial data

Product Group	15 (I/O System)
eCl@ss 10.0	27-24-26-92
eCl@ss 9.0	27-24-26-92
ETIM 8.0	EC002584
ETIM 7.0	EC002584
PU (SPU)	1 pcs
Packaging type	Bag
Country of origin	DE
GTIN	4050821096030
Customs tariff number	85366990990

### Environmental Product Compliance

RoHS Compliance Status	Compliant, No Exemption
------------------------	-------------------------

### Approvals / Certificates

#### General approvals



Approval	Standard	Certificate Name
UL Underwriters Laboratories Inc. (ORDINARY LOCATIONS)	UL 508	E175199 Sec.1

## Downloads

### Environmental Product Compliance

#### Compliance Search

Environmental Product  
Compliance 750-965



## Documentation

### Manual

System Manual WAGO	V 3.3.3	pdf	↓
I/O System 750/753	29.08.2023	8512.61 KB	

### Bid Text

750-965	06.10.2017	doc	24.50 KB	↓
750-965	19.02.2019	xml	4.43 KB	



## CAD/CAE-Data

### CAE data

EPLAN Data Portal  
750-965

