

Communicative damper actuator fail-safe and extended functionalities for adjusting dampers in technical building installations

- Air damper size up to approx. 8 m<sup>2</sup>
- Torque motor 40 Nm
- Nominal voltage AC/DC 24 V
- Control modulating, communicative, hybrid
- Communication via BACnet MS/TP, Modbus RTU, Belimo-MP-Bus or conventional control
- Conversion of sensor signals

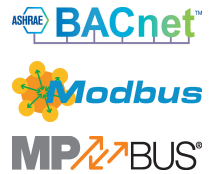

## Technical data

<b>Electrical data</b>	Nominal voltage	AC/DC 24 V
	Nominal voltage frequency	50/60 Hz
	Nominal voltage range	AC 19.2...28.8 V / DC 21.6...28.8 V
	Power consumption in operation	11 W
	Power consumption in rest position	3 W
	Power consumption for wire sizing	21 VA
	Power consumption for wire sizing note	Imax 20 A @ 5 ms
	Connection supply / control	Cable 1 m, 6x 0.75 mm <sup>2</sup>
<b>Data bus communication</b>	Communicative control	BACnet MS/TP Modbus RTU (factory setting) MP-Bus
	Number of nodes	BACnet / Modbus see interface description MP-Bus max. 8
<b>Functional data</b>	Torque motor	40 Nm
	Operating range Y	2...10 V
	Operating range Y variable	0.5...10 V
	Position feedback U	2...10 V
	Position feedback U note	Max. 1 mA
	Position feedback U variable	Start point 0.5...8 V End point 2...10 V
	Setting fail-safe position	0...100%, adjustable in increments of 10% (POP rotary knob on 0 corresponds to left end stop)
	Bridging time (PF)	2 s
	Bridging time (PF) variable	0...10 s
	Position accuracy	±5%
	Direction of motion motor	selectable with switch 0/1
	Direction of motion note	Y = 0%: At switch position 0 (ccw rotation) / 1 (cw rotation)
	Direction of motion variable	electronically reversible
	Direction of motion fail-safe	selectable with switch 0...100%
	Manual override	with push-button
Angle of rotation	Max. 95°	
Angle of rotation note	can be limited on both sides with adjustable mechanical end stops	
Running time motor	150 s / 90°	
Running time motor variable	90...150 s	

**Technical data**

<b>Functional data</b>	Running time fail-safe	35 s / 90°	
	Adaptation setting range	manual	
	Adaptation setting range variable	No action Adaptation when switched on Adaptation after pushing the manual override button	
	Override control, controllable via bus communication	MAX (maximum position) = 100% MIN (minimum position) = 0% ZS (intermediate position) = 50%	
	Override control variable	MAX = (MIN + 32%)...100% MIN = 0%...(MAX - 32%) ZS = MIN...MAX	
	Sound power level, motor	52 dB(A)	
	Sound power level, fail-safe	61 dB(A)	
	Mechanical interface	Universal shaft clamp reversible 12...26.7 mm	
	Position indication	Mechanical, pluggable	
	<b>Safety data</b>	Protection class IEC/EN	III, Safety Extra-Low Voltage (SELV)
		Power source UL	Class 2 Supply
Degree of protection IEC/EN		IP54	
Degree of protection NEMA/UL		NEMA 2	
Enclosure		UL Enclosure Type 2	
EMC		CE according to 2014/30/EU	
Certification IEC/EN		IEC/EN 60730-1 and IEC/EN 60730-2-14	
UL Approval		cULus according to UL60730-1A, UL60730-2-14 and CAN/CSA E60730-1 The UL marking on the actuator depends on the production site, the device is UL-compliant in any case	
Hygiene test		According to VDI 6022 Part 1 / SWKI VA 104-01, cleanable and disinfectable, low emission	
Type of action		Type 1.AA	
Rated impulse voltage supply / control		0.8 kV	
Pollution degree		3	
Ambient humidity		Max. 95% RH, non-condensing	
Ambient temperature		-30...50°C [-22...122°F]	
Storage temperature		-40...80°C [-40...176°F]	
Servicing		maintenance-free	
<b>Weight</b>		Weight	1.1 kg
<b>Terms</b>	Abbreviations	POP = Power off position / fail-safe position PF = Power fail delay time / bridging time	

**Safety notes**



- This device has been designed for use in stationary heating, ventilation and air-conditioning systems and must not be used outside the specified field of application, especially in aircraft or in any other airborne means of transport.
- Outdoor application: only possible in case that no (sea) water, snow, ice, insolation or aggressive gases interfere directly with the device and that it is ensured that the ambient conditions remain within the thresholds according to the data sheet at any time.
- Only authorised specialists may carry out installation. All applicable legal or institutional installation regulations must be complied with during installation.
- The device may only be opened at the manufacturer's site. It does not contain any parts that can be replaced or repaired by the user.
- Cables must not be removed from the device.
- To calculate the torque required, the specifications supplied by the damper manufacturers concerning the cross-section and the design, as well as the installation situation and the ventilation conditions must be observed.
- Self adaptation is necessary when the system is commissioned and after each adjustment of the angle of rotation (press the adaptation push-button once).
- The device contains electrical and electronic components and must not be disposed of as household refuse. All locally valid regulations and requirements must be observed.

**Product features**

**Operating mode** The actuator is fitted with an integrated interface for BACnet MS/TP, Modbus RTU and MP-Bus. It receives the digital control signal from the control system and returns the current status.

**Pre-charging time (start up)** The capacitor actuators require a pre-charging time. This time is used for charging the capacitors up to a usable voltage level. This ensures that, in the event of a power failure, the actuator can move at any time from its current position into the preset fail-safe position. The duration of the pre-charging time depends mainly on following factors:

- Duration of the power failure
- PF delay time (bridging time)

Typical pre-charging time

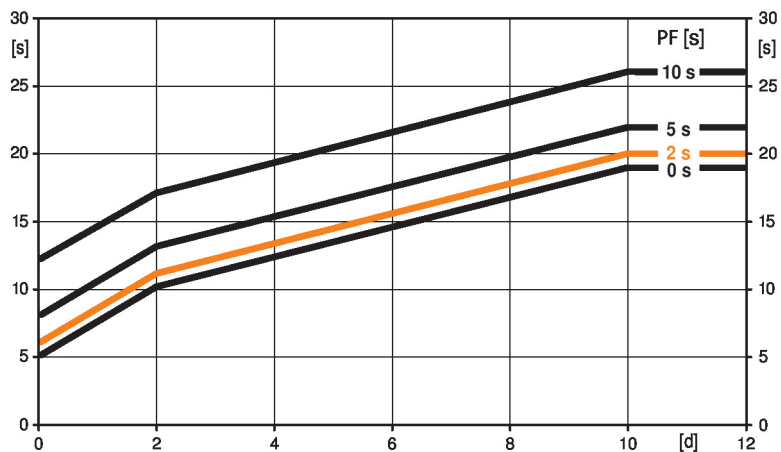

[d] = Power failure in days  
 [s] = Pre-charging time in seconds  
 PF[s] = Bridging time  
 Calculation example: Given a power failure of 3 days and a bridging time (PF) set at 5 s, the actuator requires a pre-charging time of 14 s after the power has been reconnected (see graphic).

PF [s]	[d]				
	0	1	2	7	≥10
0	5	8	10	15	19
2	6	9	11	16	20
5	8	11	13	18	22
10	12	15	17	22	26

[s]

<b>Delivery condition (capacitors)</b>	The actuator is completely discharged after delivery from the factory, which is why the actuator requires approximately 20 s pre-charging time before initial commissioning in order to bring the capacitors up to the required voltage level.
<b>Bridging time</b>	<p>Power failures can be bridged up to a maximum of 10 s.</p> <p>In the event of a power failure, the actuator will remain stationary in accordance with the set bridging time. If the power failure is greater than the set bridging time, the actuator will move into the selected fail-safe position.</p> <p>The bridging time set at the factory is 2 s. It can be modified on site in operation by means of the Belimo service tool MFT-P.</p> <p>Settings: The rotary knob must not be set to the "Tool" position!</p> <p>For retroactive adjustments of the bridging time with the Belimo service tool MFT-P or with the ZTH EU adjustment and diagnostic device only the values need to be entered.</p>
<b>Setting fail-safe position (POP)</b>	<p>The rotary knob fail-safe position can be used to adjust the desired fail-safe position 0...100% in 10% increments.</p> <p>The rotary knob refers only to the adapted angle of rotation range 30°...95°. No set min. or max. values are observed.</p> <p>In the event of a power failure, the actuator will move into the selected fail-safe position, taking into account the bridging time that has been set.</p> <p>Settings: The rotary knob must be set to the «Tool» position for retroactive settings of the fail-safe position with the Belimo service tool MFT-P. Once the rotary knob is set back to the range 0...100%, the manually set value will have positioning authority.</p>
<b>Converter for sensors</b>	Connection option for a sensor (passive, active or with switching contact). In this way, the analogue sensor signal can be easily digitised and transferred to the bus systems : BACnet, Modbus or MP-Bus.
<b>Parametrisable actuators</b>	<p>The factory settings cover the most common applications. Single parameters can be modified with the Belimo service tools MFT-P or ZTH EU.</p> <p>The communication parameters of the bus systems (address, baud rate etc.) are set with the ZTH EU. Pressing the "Address" button on the actuator while connecting the supply voltage resets the communication parameters to the factory setting.</p> <p>Quick addressing: The BACnet and Modbus address can alternatively be set using the buttons on the actuator and selecting 1...16. The selected value is added to the "basic address" parameter and results in the absolute BACnet and Modbus address.</p>
<b>Combination analogue - communicative (hybrid mode)</b>	With conventional control by means of an analogue control signal, BACnet or Modbus can be used for the communicative position feedback
<b>Simple direct mounting</b>	Simple direct mounting on the damper shaft with a universal shaft clamp, supplied with an anti-rotation device to prevent the actuator from rotating.
<b>Manual override</b>	Manual control with push-button possible - temporary. The gear train is disengaged and the actuator decoupled for as long as the button is pressed.
<b>High functional reliability</b>	The actuator is overload protected, requires no limit switches and automatically stops when the end stop is reached.
<b>Home position</b>	<p>The first time the supply voltage is switched on, i.e. at the time of commissioning, the actuator carries out a synchronisation. The synchronisation is in the home position (0%).</p> <p>The actuator then moves into the position defined by the control signal.</p>

**Product features**

<b>Adaptation and synchronisation</b>	<p>An adaptation can be triggered manually by pressing the "Adaptation" button or with the PC-Tool. Both mechanical end stops are detected during the adaptation (entire setting range). Automatic synchronisation after pressing the manual override button is configured. The synchronisation is in the home position (0%).</p> <p>The actuator then moves into the position defined by the control signal.</p> <p>A range of settings can be adapted using the PC-Tool (see MFT-P documentation)</p>
<b>Setting direction of motion</b>	<p>When actuated, the direction of the rotation switch changes the running direction in normal operation. The direction of the rotation switch has no influence on the fail-safe position which has been set.</p>

**Accessories**

<b>Electrical accessories</b>	<b>Description</b>	<b>Type</b>
	Auxiliary switch 1x SPDT add-on	S1A
	Auxiliary switch 2x SPDT add-on	S2A
	Feedback potentiometer 140 Ω add-on	P140A
	Feedback potentiometer 1 kΩ add-on	P1000A
	Feedback potentiometer 10 kΩ add-on	P10000A
	Adapter for auxiliary switch and feedback potentiometer, Multipack 20 pcs.	Z-SPA
<b>Mechanical accessories</b>	<b>Description</b>	<b>Type</b>
	Actuator arm for standard shaft clamp	AH-GMA
	Damper crank arm Slot width 8.2 mm, clamping range ø14...25 mm	KH10
	Mounting kit for linkage operation for flat installation	ZG-GMA
<b>Tools</b>	<b>Description</b>	<b>Type</b>
	Service tool, with ZIP-USB function, for parametrisable and communicative Belimo actuators, VAV controller and HVAC performance devices	ZTH EU
	Belimo PC-Tool, Software for adjustments and diagnostics	MFT-P
	Adapter for Service-Tool ZTH	MFT-C
	Connecting cable 5 m, A: RJ11 6/4 ZTH EU, B: 6-pin for connection to service socket	ZK1-GEN
	Connecting cable 5 m, A: RJ11 6/4 ZTH EU, B: free wire end for connection to MP/PP terminal	ZK2-GEN
	* Adapter Z-SPA	
	It is imperative that this adapter will be ordered if an auxiliary switch or a feedback potentiometer is required and if at the same time the shaft clamp is installed on the rear side of the actuator (e.g. with short shaft installation).	

**Electrical installation**

**Supply from isolating transformer.**

**The wiring of the line for BACnet MS/TP / Modbus RTU is to be carried out in accordance with applicable RS-485 regulations.**

**Modbus / BACnet: Supply and communication are not galvanically isolated. Connect earth signal of the devices with one another.**

**Wire colours:**

- 1 = black
- 2 = red
- 3 = white
- 5 = orange
- 6 = pink
- 7 = grey

**Functions:**

- C1 = D- = A (wire 6)
- C2 = D+ = B (wire 7)

**Electrical installation**

**Wiring diagrams**

BACnet MS/TP / Modbus RTU

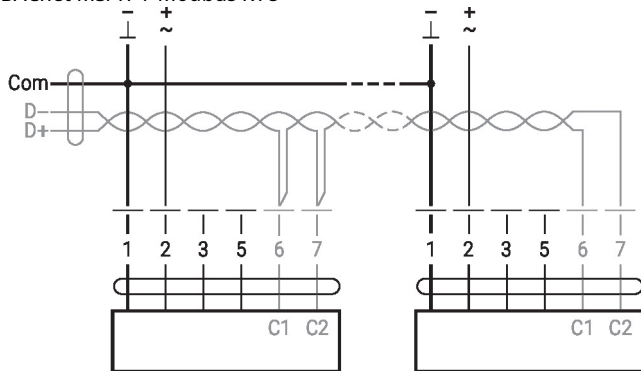

**Functions**

**Functions with specific parameters (Parametrisation necessary)**

Modbus RTU / BACnet MS/TP with analogue setpoint (hybrid operation)

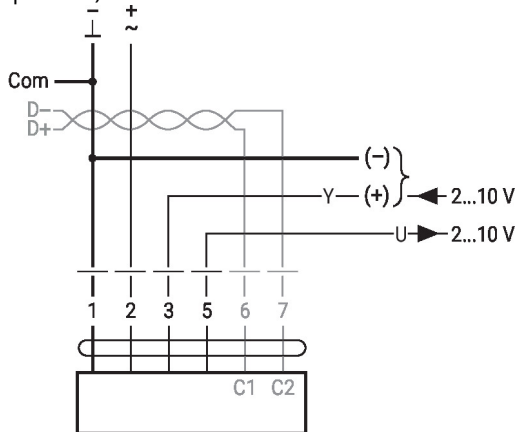

Connection with active sensor, e.g. 0...10 V @ 0...50°C

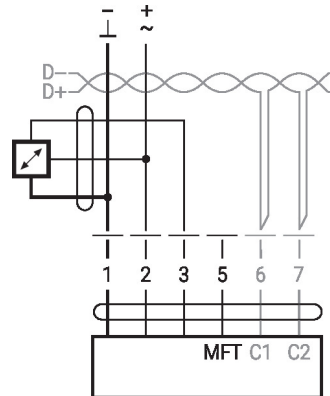

Possible input voltage range:  
0...10 V  
Resolution 30 mV

Connection with switching contact, e.g. Δp monitor

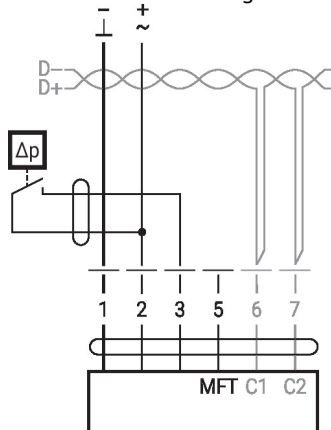

Switching contact requirements:  
The switching contact must be able to switch a current of 16 mA at 24 V accurately.  
Start point of the operating range must be parametrised on the MOD actuator as  $\geq 0.5$  V.

**Functions**

**Functions with specific parameters (Parametrisation necessary)**

Connection with passive sensor, e.g. Pt1000, Ni1000, NTC

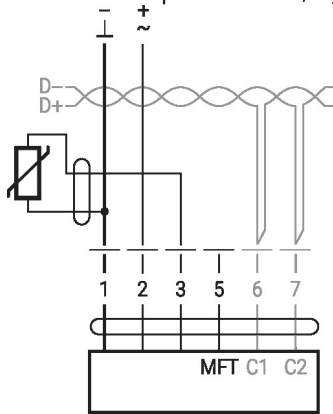

Ni1000	-28...+98°C	850...1600 Ω <sup>2)</sup>
PT1000	-35...+155°C	850...1600 Ω <sup>2)</sup>
NTC	-10...+160°C <sup>1)</sup>	200 Ω...60 kΩ <sup>2)</sup>

1) depending on type  
2) Resolution 1 Ohm  
Compensation of the measured value is recommended

**MP-Bus**

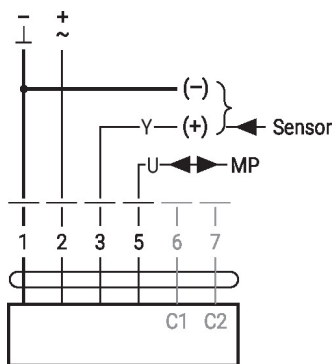

**MP-Bus Network topology**

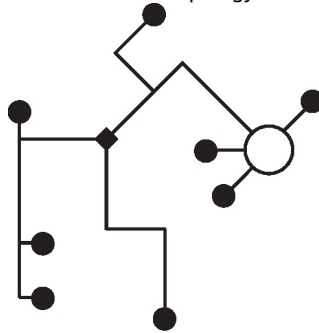

There are no restrictions for the network topology (star, ring, tree or mixed forms are permitted).  
Supply and communication in one and the same 3-wire cable

- no shielding or twisting necessary
- no terminating resistors required

## Operating controls and indicators

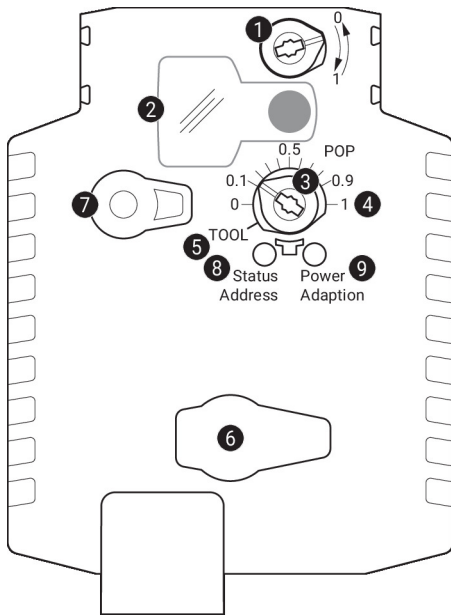
**1** Direction of stroke switch

Switch over:                      Direction of stroke changes

**2** Cover, POP button

**3** POP button

**4** Scale for manual adjustment

**5** Position for adjustment with tool

**6** Service plug

For connecting parametrisation and service tools

**7** Manual override button

Press button:            Gear train disengages, motor stops, manual override possible

Release button:        Gear train engages, standard mode

LED displays

yellow <b>8</b>	green <b>9</b>	Meaning / function
Off	On	Operation OK
Off	Flashing	POP function active When starting: Reset to factory setting (Communication)
On	Off	- Pre-charging time SuperCap - Fault SuperCap - Wiring error in supply
Off	Off	Not in operation
On	On	Adaptation or synchronisation process active
On	Flashing	Actuator in address mode Pulses according to set address (1...16)
Flickering	On	BACnet / Modbus communication active

**8** Push-button (LED yellow)

 Press button:        In operation (>3 s): Switch address mode on and off  
                           In address mode: Address setting by pressing several times  
                           When starting (>5 s): Reset to factory setting (Communication)

**9** Push-button (LED green)

 Press button:        In operation: Triggers stroke adaptation, followed by standard mode  
                           In address mode: Confirmation of set address (1...16)



Operating controls and indicators

Setting emergency setting position (POP)

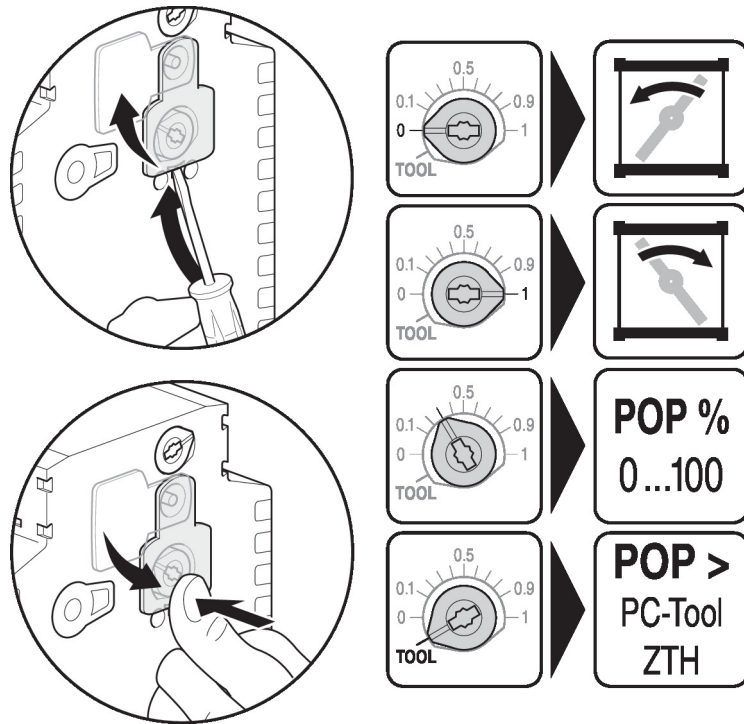

Service

- Quick addressing**
1. Press the "Address" button until the green "Power" LED is no longer illuminated. The green "Power" LED flashes in accordance with the previously set address.
  2. Set the address by pressing the "Address" button the corresponding number of times (1...16).
  3. The green LED flashes in accordance with the address that has been entered (1...16). If the address is not correct, it can be reset in accordance with step 2.
  4. Confirm the address setting by pressing the green "Adaptation" button.
- If the address is not confirmed within 60 seconds, the address procedure will be ended. Any address change that has already been started will be discarded.
- The resulting BACnet MS/TP and Modbus RTU address is made up of the set basic address plus the short address (e.g. 100+7=107).

**Tool connection** The actuator can be parametrised by ZTH EU via the service socket. For an extended parametrisation the PC tool can be connected.

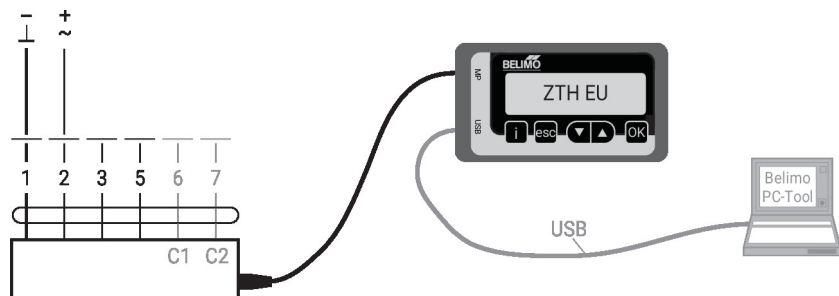

## Dimensions

## Spindle length

		Min. 52
		Min. 20

## Clamping range

	12...22	12...18
	22...26.7	12...18

\*Option: Shaft clamp mounted below: If an auxiliary switch or a feedback potentiometer is used the adapter Z-SPA is required.

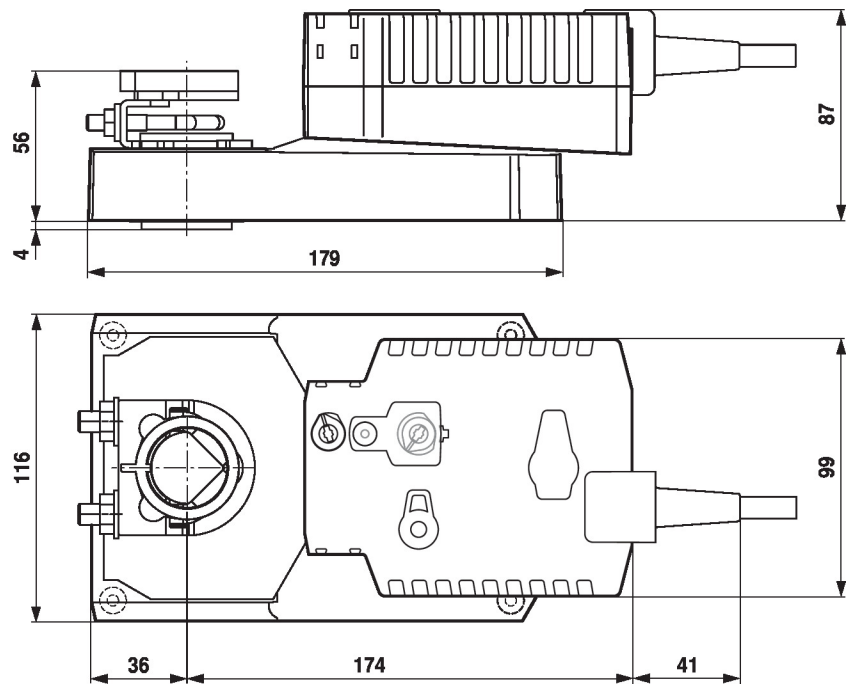

## Further documentation

- Tool connections
- BACnet Interface description
- Modbus Interface description
- Overview MP Cooperation Partners
- MP Glossary
- Introduction to MP-Bus Technology